



SMARTSCAN | NG²

Operator's Guide for Union Pacific

EUD-2018080-00 Rev.7
07 March 2025

© 2025 Southern Technologies Corporation (STC). All rights reserved.
Printed in the USA.

Because products evolve and system configurations change, this manual may not be an exact representation of the products and systems that you are using.

Software Version at the time of this publication

UP_06-12x 2025-01-21

STC assumes no responsibility for errors or omissions in this document. Nor does STC make any commitment to update the information contained herein.

Product and company names mentioned herein are trademarks or registered trademarks of their respective owners.

WARNING!

Contact with electrically active parts could result in sparks, burns, and electric shock. Because of this, you should avoid all electrical hazards when installing, wiring, operating, and maintaining the SmartScanNG² system. Failure to do so could result in damage to the equipment or serious injury to you.

NOTICE:

If equipped with an AEI subsystem, the user is required to obtain a Part 90 site license from the FCC to operate in the United States. See product label for FCC ID number. Access the FCC Web site <https://www.fcc.gov/licensing-databases/forms> for additional information concerning licensing requirements.

Users in all countries should check with the appropriate local authorities for licensing requirements.



6145 Preservation Drive, Chattanooga, TN 37416

web: www.southern-tech.com

email: stcemail@southern-tech.com

fax number: 423-499-0045

telephone number: 423-892-3029

Contents

This section lists the headings of this guide in sequential order with their page references.

Contents	3
1.0 Introduction	7
1.1 Purpose of This Guide.....	7
1.2 SmartScanNG ²	7
1.3 General Specifications - SmartScanNG ²	9
1.4 Cautions.....	10
1.5 Disclaimers.....	10
1.6 How to Comment on This Guide.....	10
1.7 How to Order More Copies of This Guide.....	10
1.8 Standard Warranty	11
2.0 Defect Detection.....	13
2.1 System Activation.....	13
2.2 System Deactivation.....	14
2.3 Speed Calculation	14
2.4 Train Direction.....	14
2.5 Transducer Pulse Processing.....	15
2.6 Axle Scanning	16
2.7 Hot Bearing Alarms	17
2.7.1 Bearing Scan Process	17
2.7.2 Referencing System	19
2.7.3 Pyrometer Linearity.....	19
2.8 Hot Wheel Alarms	20
2.9 Auxiliary Alarms.....	21
3.0 Display Panel	23
3.1 LED Indicators.....	23
3.2 Keypad & Display	24
3.3 System Functions.....	25
3.3.1 System Health Menu	25
3.3.2 Radio Test.....	25
3.3.3 Scanner Cal. Menu.....	26
3.3.4 Network Menu	26
3.3.5 Radio IO Status	27
3.3.6 Volume Menu	27
3.3.7 System IO Status.....	28
3.3.8 Test Train	28
3.3.9 Tag Reader Test.....	29
3.3.10 Efficiency Test	30
4.0 Serial Interface.....	31
4.1 Main Menu	32
4.2 Setup Menu.....	34
4.2.1 Date and Time	36

4.2.2	Site ID	37
4.2.3	Milepost/Kilometer Post (MP/KP)	38
4.2.4	Track Designation	39
4.2.5	Track Direction	40
4.2.6	Alarm Settings.....	40
4.2.7	Equipment Settings	48
4.2.8	Messages.....	62
4.2.9	AEI Reader Settings.....	68
4.2.10	Load Default Setup Parameters	72
4.2.11	COM1, COM2, COM3, COM4, COM6, & RS485	75
4.2.12	Network Settings	76
4.2.13	Talker Mode	79
4.2.14	Velocity	80
4.2.15	Wind Settings	80
4.3	System Functions Menu.....	83
4.4	Replay Train Announcements.....	108
4.5	System Security.....	109
5.0	Web User Interface	111
5.1	Train Data.....	113
5.2	System Status.....	116
5.3	Configuration	117
5.4	System Event Log.....	132
5.5	Maintenance Info	133
5.6	System Functions	134
5.7	Remote Software Update.....	135
5.8	Auto Calibration	136
6.0	Producing Reports.....	137
6.1	Train Summary Report.....	139
6.2	Train Detail Report.....	143
6.3	Abbreviated Train Detail Report	150
6.4	Exception Summary Report	152
6.5	Exception Detail Report	155
6.6	Abbreviated Exception Detail Report.....	159
6.7	System Status Report	161
6.8	Last Train Report	165
6.9	Range of Trains Report.....	165
6.10	Train DSRs	166
6.11	AEI Diagnostic Detail Report.....	170
6.12	Event Log Report.....	175
7.0	Radio Announcements	177
7.1	Arrival Messages	178
7.2	Real-Time Messages	178
7.3	Post-Train Messages	180
7.3.1	Nothing Detected	182
7.3.2	Only an Integrity Failure Detected	183
7.3.3	Exception Alarms Detected	184
7.4	Rebroadcasting Post-Train Messages	189
8.0	Scheduled Maintenance	191

9.0 Customer Service	209
9.1 Reaching STC	209
9.2 Returning Equipment for Repair	209
9.3 Reporting Problems or Suggestions	210
9.4 Ordering Spare Parts.....	210
9.5 Checking on Shipments and Orders	210
Appendix A System Alarms	211
A.1 AC Power Off Alarm.....	211
A.2 Advance Turn-On Failure Alarm.....	211
A.3 AEI Subsystem Alarms	211
A.4 Ambient Temperature Probe Unreliable Alarm	212
A.5 Blind Pyro Alarm	212
A.6 Cold Rail Alarm.....	212
A.7 Cold Resistor Alarm	212
A.8 Cold Wheel Scanner Resistor Alarm	213
A.9 Efficiency Test Panel in Use Alarm	214
A.10 Equal Heats Test Failed Alarm.....	214
A.11 Highrange Transducer Miscounts Alarm	214
A.12 Integrity Failure Alarm	214
A.13 Low Battery Alarm.....	215
A.14 Midrange Transducer Miscounts Alarm	215
A.15 Presence Detected On Adjacent Track Alarm	215
A.16 Pyrometer Noise Filtered Rail Alarm	215
A.17 Pyrometer Noise Filtered Wheel Alarm	216
A.18 Rail Resistor Test Overridden Alarm	216
A.19 Reverse Direction Detected Alarm	216
A.20 Short Train Alarm.....	217
A.21 Stuck Dragger Recovered Alarm.....	217
A.22 Test Train Alarm.....	217
A.23 Successive Cold Wheel Resistors Exceeded Alarm	217
A.24 Wheel Resistor Test Overridden Alarm	217
A.25 Very Slow Train Alarm	218
Appendix B Integrity Failures.....	219
B.1 Dead Battery Alarm.....	219
B.2 Dead Resistor Alarm	219
B.3 Highrange Transducer Miscounts Alarm	219
B.4 Max Equal Heat Test Failures Exceeded Alarm	220
B.5 Maximum Exception Alarms Exceeded Alarm	220
B.6 Midrange Transducer Miscounts Alarm	220
B.7 Pre-train Stuck Dragger Alarm	221
B.8 Pre-train Stuck High-Load Detector Alarm	221
B.9 Spike Event.....	221
B.10 Stuck Dragger During Train Passage Alarm.....	221
B.11 Pre-train Stuck Wide-Load Detector Alarm.....	221
B.12 Successive Cold Rails Exceeded Alarm.....	222
B.13 Successive Cold Resistors Exceeded Alarm	222
B.14 Train Present on Restart Alarm	222

B.15 Very Slow Train Alarm	222
Appendix C Replacement of Type II Scanners	223
C.1 Bearing Scanners.....	223
C.2 Wheel Scanners.....	225
Appendix D Replacement of Type III Scanners.....	227
D.1 Bearing Scanners.....	227
D.2 Wheel Scanners.....	230
Appendix E Calibration of Type II Scanners.....	233
E.1 Type II Bearing Scanners	233
E.2 Type II Wheel Scanners	239
E.3 Heat Source: Power Cable Warning	244
Appendix F Calibration of Type III Scanners.....	245
F.1 Bearing Scanners	245
F.2 Wheel Scanners	251
F.3 Heat Source: Power Cable Warning	256
Appendix G Lens Cleaning of Scanners.....	257
G.1 Type III Scanners.....	257
G.2 Type II Scanners.....	259
Appendix H Predictive Gate Scanning	261
H.1 Overview	261
H.2 Scanning Process	262
H.3 Reporting the Pyrometer Saturation Alarm	263
Appendix I 2500-402 Spacer Kit Installation.....	265
Appendix J Scanner Resistor Baseline Acquisition	267
J.1 Bungalow Speaker Announcements.....	267
J.2 Processing Resistor Baseline Results	268
Appendix K Communications Ports	271
Appendix L Scanner Base Drain Hole	273
Appendix M Calibration of the PD8-Plus Presence Detector.....	275
Appendix N Track Circuit Frequency Configuration	277
Appendix O AAR Radio Frequencies.....	279
Index.....	281

1.0 Introduction

This section summarizes the purpose of this guide, describes the SmartScanNG² system, tells how to comment on this guide, and tells how to order more copies of this guide. It also covers the cautions and disclaimers of which the customer should be aware.

1.1 Purpose of This Guide

The technical staff at Southern Technologies Corporation (STC) created the SmartScanNG² system. This guide describes that system.

The SmartScanNG² system monitors moving trains and reports certain conditions detected on these trains. Parts of the system, like the bearing scanners, are installed on the tracks. Other parts of the system, like the controller module, are installed near the tracks. Most nontrackside components are factory-installed inside a wayside enclosure (aka bungalow). Therefore, the installation of these already installed components isn't covered in this guide.

The SmartScanNG² system is modular and firmware-driven. Hardware and firmware can be changed to meet the unique needs of a given railroad. Thus, some of the components that make up a SmartScanNG² system differ from railroad to railroad.

This guide is for those who purchase, install, maintain, troubleshoot, manage, or use the SmartScanNG² system as configured for UP Railway.

1.2 SmartScanNG²

The SmartScanNG² system is a full-featured detection and reporting system. It monitors moving trains, providing real-time detection of:

- Overheated bearings
- Overheated wheels, when wheel scanners are installed and enabled
- Dragging equipment, when dragging-equipment detectors are installed and enabled
- Shifted loads, when wide-load detectors are installed and enabled
- Oversized loads, when high-load detectors are installed and enabled
- Automatic Equipment Identification (AEI) tags, when AEI hardware and firmware are installed and enabled
- Train Direction
- Train Speed

The SmartScanNG² system runs well in harsh environments found along right-of-ways. It runs under the most adverse weather conditions, functioning over a temperature range of -40°F to +160°F (-40°C to +71°C). It runs in high-vibration situations. It runs unattended, carrying out all tasks without human intervention.

The SmartScanNG² system monitors trains traveling from 7 to 90 mph (11.3 to 145 kph). It monitors trains heading in either direction on the track.

When the SmartScanNG² system detects a defect, it informs the crew of the affected train via a voice transmission over an assigned radio channel. The voice is computer-generated from previously digitized human speech. It tells the crew the milepost of the reporting SmartScanNG² system, a warning that a defect has been detected, and other defect-related information. When no defect is detected, the voice tells the crew that the train was scanned and found free of defects.

There are three types of messages:

- **real-time messages** - announced as the train is passing over the site
- **post-train messages** – announced after the train has left the site
- **arrival messages** (if enabled) - announced as the train enters the site.

The content and use of these three message types are railroad-specific.

The results of train scans are stored for later use. With this stored data, the system can create formatted reports. To get them at the site, you need a computer. With a network connection and a computer, you can retrieve them remotely.

1.3 General Specifications - SmartScanNG²

Maximum Train Length	Successfully scanned computer-simulated trains with axle counts greater than 4000 axles.
Input Voltage - DC	Controller Module and Chassis: 10 to 30 VDC. Maximum system current, including two bearing scanners and two wheel scanners, with train present and radio transmitting approximately 11.7 amps. Idle current 900mA.
Input Voltage - AC	100 – 130 Volts @ 15 Amps, 50-60Hz
Input Voltage Protection	Circuit Breaker, Self-Restoring Fuses, Metal Oxide Varistors, Reverse Polarity Protected
Processors	Two Embedded Processor Modules, each with the following features: Motorola ColdFire® Processor, 32-bit, 250MHz clock (125MHz bus), 64MB DDR2 RAM, 32MB non-volatile Flash, 16GB Micro SD. Non-volatile time/date, system configuration, and train storage.
Serial Communications Ports	Up to six RS-232 ports are available, depending on internal options, and one RS-485 port – all with standard male D-Sub 9 connectors.
User Accessible Inputs	2 Bearing Scanner, 2 Wheel Scanner, 2 Wheel Gating Transducer, 2 Wheel Advanced Transducer, 8 Opto-Isolated Digital, 1 Precision Ambient Temperature Probe, 1 Train Presence Detection - Internal 2-Wire Audio Overlay Track Circuit
Network	One 10/100 Mbps Ethernet port with a standard RJ45 connector for networking capabilities. One RJ45 connector for access to the optional internal Velocity Module.
Voice Communications	Internal VHF Radio Transceiver: Ritron DTX-160 – 8 channels, 6 watts, narrowband, 134MHz to 176MHz. Additionally equipped with a radio interface for customer-specified analog or NXDN™ digital mobile radio
Dual-tone Multi-frequency Decoder	DTMF decoder recognizes all standard digits – 0 through 9, #, *, A, B, C, D. (Reception of a customer-specified sequence of digits triggers a rebroadcast of the last voice announcement.)
Secure Wireless Access	The NG ² supports wireless standards IEEE 802.11 b/g/n with 2.4GHz RF band power amplifier. Secure data communications with 128-bit WEP, WPA-PSK (TKIP), WPA2-PSK Authentication. This feature can be enabled/disabled from the keypad.
Operating Temperature	-40°C to +71°C, Fanless Operation, Industrial Temperature Range
Size	15.5"W x 22.0"H x 4.5"D
Weight	31 lbs.
Finish	White powder coat over stainless steel.
Manufacturer	Southern Technologies Corporation, Chattanooga, Tennessee

1.4 Cautions

Contact with electrically active parts could result in sparks, burns, and electric shock. Because of this, you should avoid all electrical hazards when installing, wiring, operating, and maintaining the SmartScanNG² system. Failure to do so could result in damage to the equipment or serious injury to you.

In operation, batteries generate and release flammable hydrogen gas, which, if ignited by a burning cigarette, naked flame, or spark, may cause a battery explosion with a dispersion of casing fragments and corrosive liquid electrolyte. So, carefully follow the manufacturer's instructions. Keep all sources of gas ignition away from the batteries, and do not allow metallic articles to contact the negative and positive terminals of a battery at the same time.

1.5 Disclaimers

The correct use of this guide, the environmental conditions at the time of installation, the method of the installation itself, and the installation of customer-supplied components are beyond the control of STC. So too, are the correct use and maintenance of all or part of the SmartScanNG² system. Therefore, the installer, user, and maintainer must assume the risk of any injury that might occur during installation, use, and maintenance of all or part of the SmartScanNG² system. STC assumes no risk, liability, or responsibility for errors and omissions on the part of the installer, user, or maintainer.

1.6 How to Comment on This Guide

We want to hear from you. Tell us what you like or don't like about this guide. Send your comments to:

Southern Technologies Corporation
Technical Publications Department
6145 Preservation Drive
Chattanooga, Tennessee 37416-3638
USA

All comments become the sole property of STC, and none will be returned.

1.7 How to Order More Copies of This Guide

When placing an order for more copies of this guide, refer to the order number shown on the cover of this guide. To request pricing and delivery, call 423-892-3029, fax 423-499-0045, or send an email to stcemail@southern-tech.com. Electronic copies of this guide are also available.

1.8 Standard Warranty

Systems manufactured by Southern Technologies Corporation carry a 14-month warranty from the date of shipment. Warranty is limited to repair or replacement, at the sole discretion of STC, of any goods found to be defective in either materials or workmanship during the 14-month period following shipment. Warranty does not apply to a product with signs of obvious abuse or a product that has been improperly installed.

STC warrants that goods represented by this warranty statement have been designed and manufactured with all reasonable care and attention to appropriate regulatory documents. STC makes no representation that the goods covered by this warranty are suitable for the application they are used for. Application of the goods is at the sole discretion of the purchaser.

The purchaser is responsible for the shipment of the defective product to STC. STC will pay the return shipping charges.

Products purchased from others, but included in STC systems, carry the original manufacturer's warranty, typically 12 months. Warranty claims for these products must be made directly to the original equipment manufacturer.

2.0 Defect Detection

This section describes the Exception Alarms (e.g., defect alarms) as well as miscellaneous train-scanning features.

2.1 System Activation

System activation is the process used to detect train presence and to prepare for train scanning. It is during the scanning process that the system checks for defects.

The SmartScanNG² system is equipped with one of two primary means of train arrival detection, which are the track circuit and the advance transducers. In case of a failure in the primary detection method, the gating transducers act as a backup to detect train arrival. Once the system senses a train's presence, it enters scanning mode. In other words, the system has been activated. It then opens the scanners' shutters, disables their heaters, and waits for further evidence of a train at the site in the form of gating transducer activity.

Once the system is active, it reads pulses from the two rail-mounted gating transducers, which are designated TO1 and TO2. On the rail nearest the wayside enclosure, these transducers mount near and to the north or east of the bearing scanner. **TO1** is the gating transducer closest to the bearing scanner. **TO2** is the one farthest from the bearing scanner.

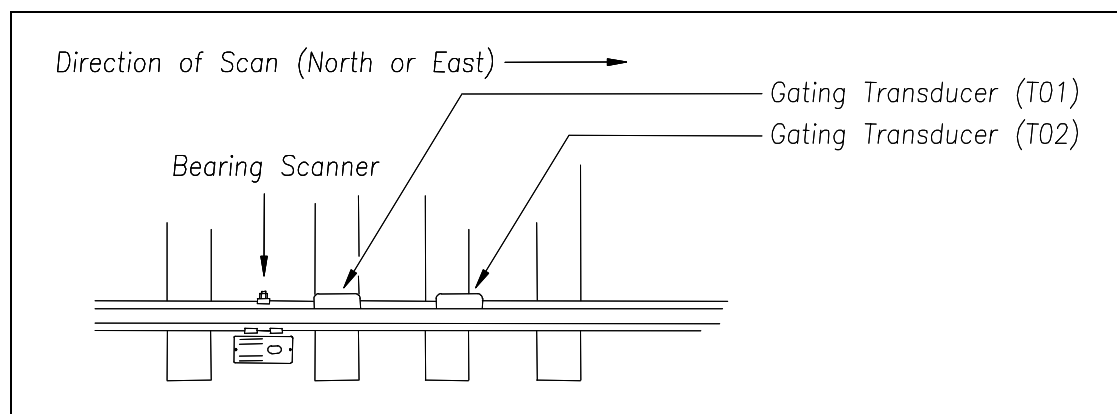

The signals from these gating transducers indicate to the system that passing wheels are in view of the scanners. Furthermore, the speed of the train is determined by using the known distance between TO1 and TO2 versus the time required for a given wheel to pass over them.

Under normal circumstances, four axles must pass over the gating transducers for the system to consider the event a valid train. Maintenance equipment having less than four axles is prevented from generating alarms and causing unwanted voice messages on the road channel.

2.2 System Deactivation

System deactivation is the process used to detect the moment that the train exits the site. Deactivation happens in one of two ways and is dependent upon whether the track circuit or one of the transducers activated the system.

If the track circuit activated the system, the system waits for the track-circuit signal to be absent for ten seconds before deactivating. Likewise, if a transducer activated the system, the system waits for ten seconds of inactivity from the gating transducers before deactivating.

2.3 Speed Calculation

Train reports show minimum, maximum, average, and exit speeds in miles per hour. The system calculates speed by knowing the distance between the two transducers versus the time that it takes a given wheel to pass over them.

Trains traveling 7 mph or less (11.3 kph) are considered "very slow." After the passage of these trains, the phrase "train too slow" is appended to the post-train message (when the Announce Slow Train option is enabled), and a diagnostic message is noted on the Train Detail and Exception Detail reports.

The report fragment below, from the header section of a Train Detail report, shows the location of this message.

```
Southern Technologies Corporation
Next Generation Detector System
TRAIN DETAIL
=====
                                .
                                .
Integrity Failures
-----
VERY Slow Train
                                .
                                .
                                .
```

2.4 Train Direction

Train direction is based on whether TO1 or TO2 generated the first gating transducer pulse.

2.5 Transducer Pulse Processing

As a wheel enters the sensing range of a transducer (magnetic), the transducer should respond with a positive-going pulse. The polarization of the two wires from the transducer determines if this pulse is positive or negative.

Here is a simple test that you can use to verify the correct polarization of the gating transducers. While watching the TO1 and TO2 LEDs on the display panel, have someone lay a metal wrench on one of the gating transducers. The corresponding LED should briefly light as the wrench touches the transducer. Then, lift the wrench. The LED shouldn't light as the wrench is lifted away. Repeat the test for the other transducer.

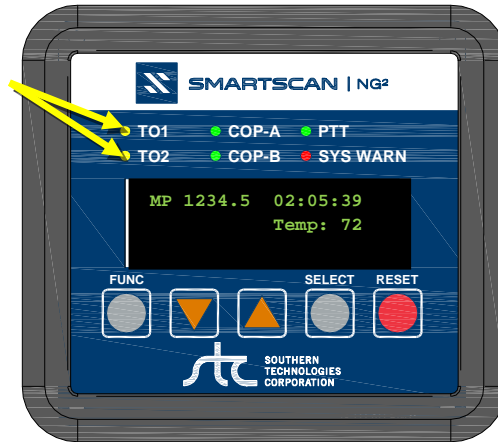

On the Interface board (in the Controller module), the transducer signals undergo RF filtering and amplification with a gain of 30. For validation, the amplified signals are fed into comparators, which create 5-VDC pulses lasting the period of time that the amplified signals remain above 620 millivolts. These 5-VDC transducer signals are fed to the microcontroller for processing.

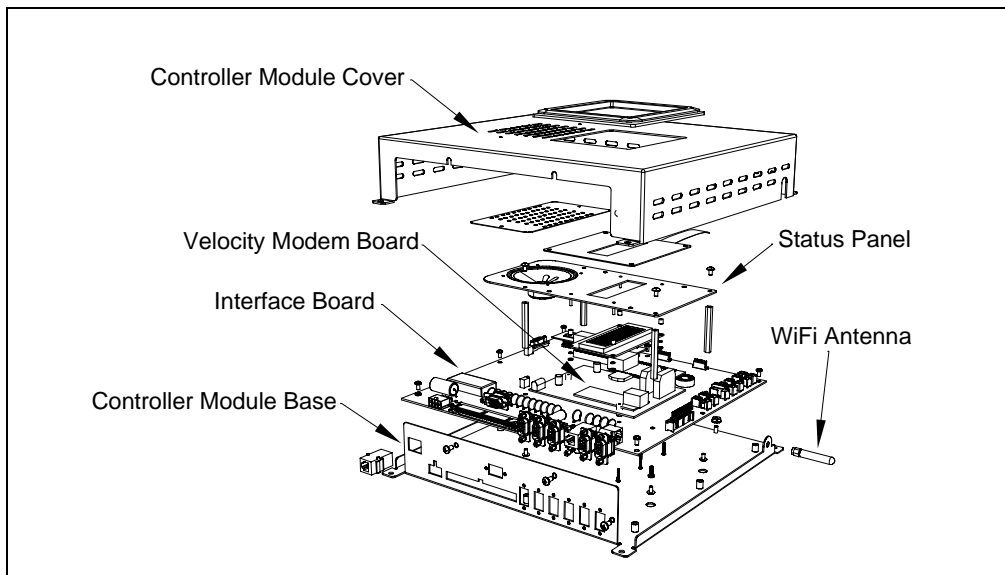

A firmware-controlled feature of the comparator circuit allows adjustment of the threshold voltage based on the speed of the train. Trains traveling less than 20 mph (32 kph) use the 620-millivolt threshold setting for maximum sensitivity. However, faster trains cause the transducers to generate a higher signal voltage, which allows the system to increase the threshold voltage. A higher threshold improves the signal-to-noise ratio, resulting in better signal validation.

Processor-A internally generates interrupts on the positive-going and negative-going edges of each transducer pulse coming from the comparator. The positive edge of each comparator pulse starts a timer. The timer stops with the detection of a negative-going edge. The width of each pulse is a determining factor of signal validity. Three milliseconds or greater is considered to be a valid signal. The firmware rejects any pulse width shorter than 3-milliseconds. Rejected pulses don't increment the transducer counters.

In normal operation, the gating transducers fire in sequence, first one, then the other. With 24-inch (61-centimeter) gating-transducer spacing, a wheel passes over both gating transducers before the next wheel passes over a gating transducer. Therefore, two consecutive pulses on the same gating transducer are typically not physically possible. However, in the unlikely event that a gating transducer is ever caused to fire by another source, such as electrical interference from a locomotive's traction motor, a spike counter for the gating transducer that misfired will be incremented by one. To increment the axle counter, one pulse from each gating transducer must occur in sequence.

2.6 Axle Scanning

The SmartScanNG² system begins sampling bearing and wheel (where wheel scanners are installed) temperatures upon detection of train arrival – when presence goes active **or** when the first wheel of the first vehicle crosses the leading gating transducer. The scanners are sampled continuously until the train exits the site. The signals from the gating transducers indicate to the system when each axle is in the scan path of the scanners. While an axle is between the two gating transducers, it is said to be “in the gate.” The heat samples from the bearing and wheel scanners are allocated to a given axle for the time periods immediately preceding the axle entering the gate, while the axle travels through the gate, and immediately following the axle exiting the gate.

The SmartScanNG² system implements a Dynamic Scan Rate (DSR) for the sampling of the temperatures detected by the scanners. The rate of scan (sampling) is adjusted, based upon the real-time speed of the train, so that the temperature of each bearing and wheel is sampled once for each half-inch of travel. For every axle, a total of 96 samples are collected from each scanner. Forty-eight samples are collected for the time that the axle is between the gating transducers (in the gate), twenty-four samples are collected from the time immediately before the axle entered the gate, and twenty-four samples are collected from the time immediately after the axle exited the gate.

2.7 Hot Bearing Alarms

The SmartScanNG² system checks for hot bearings during the axle scanning process.

There are four types of Hotbox alarms.

Absolute. To trigger an Absolute alarm, a bearing temperature must exceed the limit that was established using the Absolute option of the Alarm Settings Menu. This alarm limit is an offset, in degrees Fahrenheit, above the reference temperature.

Differential. To trigger a Differential alarm, a bearing temperature must exceed the opposite side bearing temperature of the same axle by a differential amount established using the Differential option of the Alarm Settings Menu.

Pyrometer Saturation. To trigger a Pyrometer Saturation alarm, an interaxle bearing temperature must exceed the limit that was established using the Absolute option. If an Absolute alarm or a Differential alarm has already been triggered for the axle, a Pyrometer Saturation alarm isn't generated.

Carside Slope. To trigger a Carside Slope alarm, a bearing temperature must meet or exceed a calculated alarm level and a minimum heat value. The bearing temperature must also be at least twice the opposite bearing's temperature. If an Absolute alarm or a Differential alarm has already been triggered for the axle, a Carside Slope alarm isn't generated. The minimum heat value is established using the Carside Minimum option of the Alarm Settings Menu.

2.7.1 Bearing Scan Process

Bearing scanners are mounted in the center of the crib of two ties spaced at least 14 inches (35.6 centimeters) apart. Both bearing scanners are mounted in the crib immediately ahead of the gating transducers (that is, in the crib immediately to the south or west of the gating transducers). They are mounted directly opposite each other, one on each rail of the track. The hole on the top of the scanner covers faces north or east.

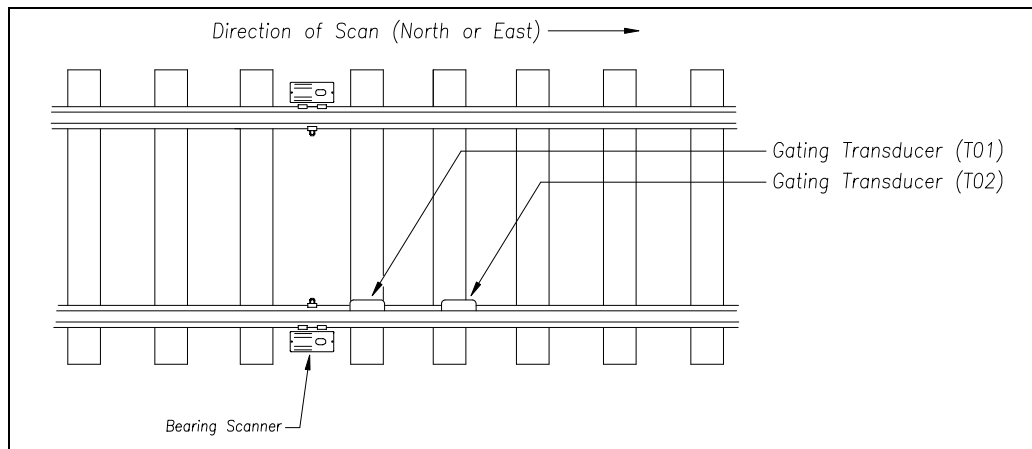

Bearing scanners are aligned to scan the bottom 3.5 inches (8.9 centimeters) of the bearing housing about 7.25 inches (18.4 centimeters) from the gauge line.

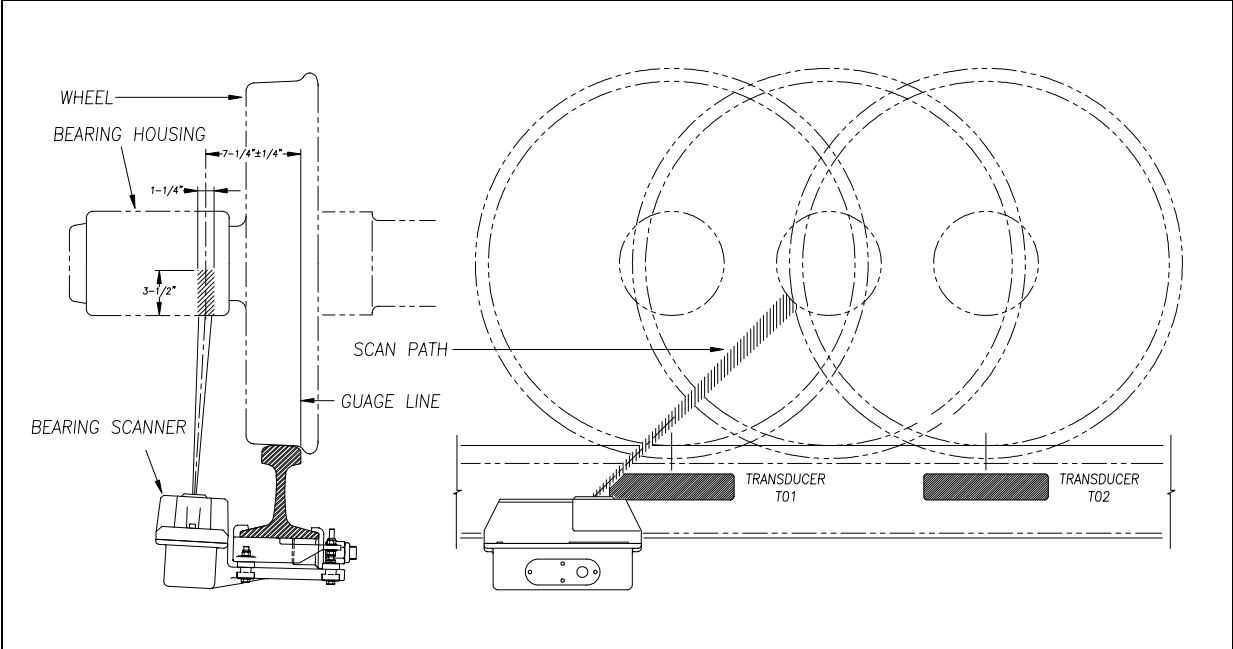

Type II Scanner

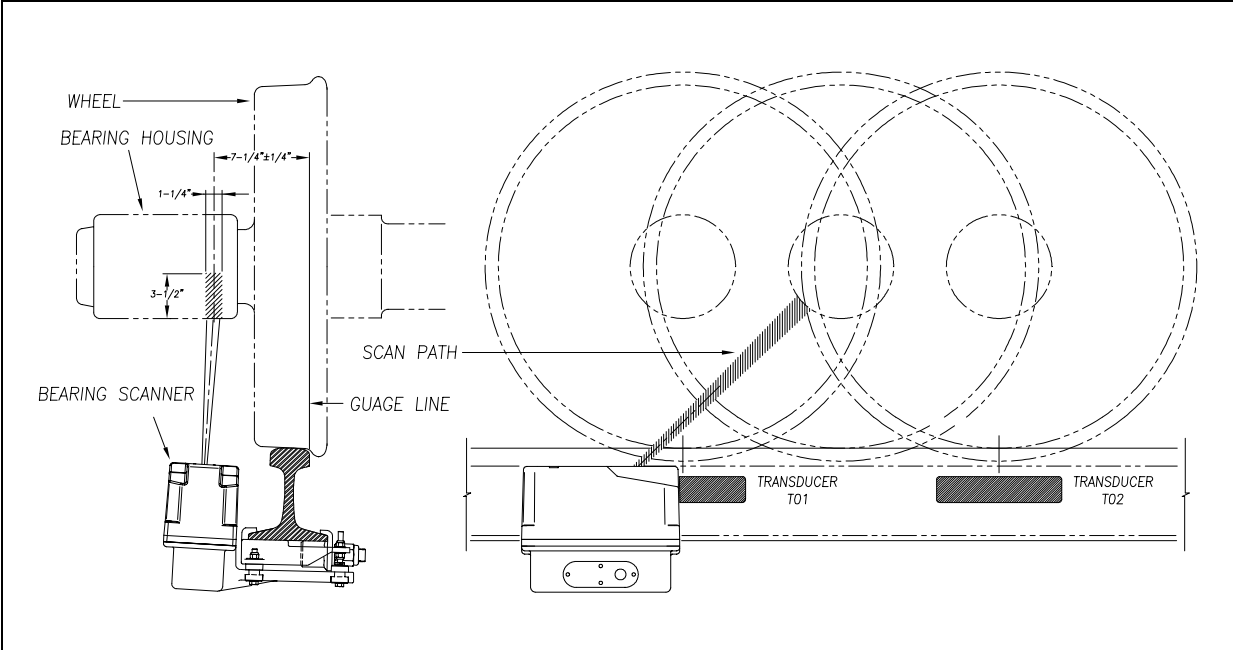

Type III Scanner

2.7.2 Referencing System

Pyrometers measure rapid changes in infrared energy emitted from objects passing through their field of view. The rail-mounted scanners are aligned to take advantage of this characteristic.

When no axle is present between the gating transducers, the scanner typically sees only the undersides of the cars passing over the site. The undersides of the cars are at or near ambient temperature, thus establishing the reference from which the elevated temperatures of bearings are measured. The pyrometers normalize during this time, producing a zero-level signal.

Occasionally, the scanners are exposed to infrared emissions that are colder than the underside of the cars. Typically, this occurs in the gaps between cars when the scanners may reference on a clear sky. This could present an erroneous reference if a bearing was scanned immediately following a sky shot, resulting in an abnormally high reading for the bearing. The pyrometers have internal circuitry to prevent the reference from shifting below the established zero reference.

When a bearing passes through the field of view of the scanner, a rapid change in temperature is presented to the internal lithium tantalate crystal. This causes the signal level from the pyrometer to increase proportionally to the amount of exposed infrared energy. When an axle is between the gating transducers, the pyrometer signal is sampled at every 1/2 inch (1.27 centimeters) of wheel movement for a total of 48 samples, and the maximum signal level is stored. This signal level measured in volts is converted to a digital value and expressed in degrees Fahrenheit above ambient temperature. This value is the basis for the alarm analysis done by the system.

2.7.3 Pyrometer Linearity

The output of the pyrometers is linear across most of the operating speed range of the system. However, the output of the pyrometers is nonlinear at either end of the operating speed range. To compensate for this nonlinear output, the firmware applies a correction factor to the sampled heat value. The correction factor applied to each bearing sample is based on the speed of the bearing (axle's ON time) as it passed through the gate and on the actual value read by the pyrometer. The correction factor is derived from a table that is keyed by the axle's ON time and heat value. Due to the fast nature of this lookup table, linearity compensation is done in real-time so that detected alarms reflect the heat value after the linearity step has been done.

2.8 Hot Wheel Alarms

When used, wheel scanners are mounted in the center of the crib of two ties spaced at least 14 inches (35.6 centimeters) apart. Both wheel scanners are mounted in the crib between the two gating transducers. They are mounted directly opposite each other, one on each rail of the track. The hole on the top of the scanner covers faces the center of the track.

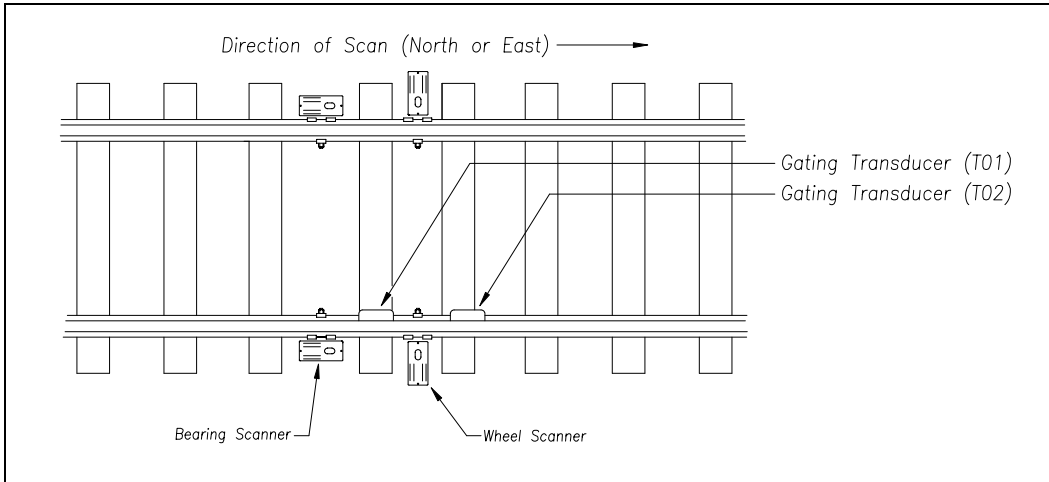

Wheel scanners are aligned to scan about 4 inches (10 centimeters) above the rail.

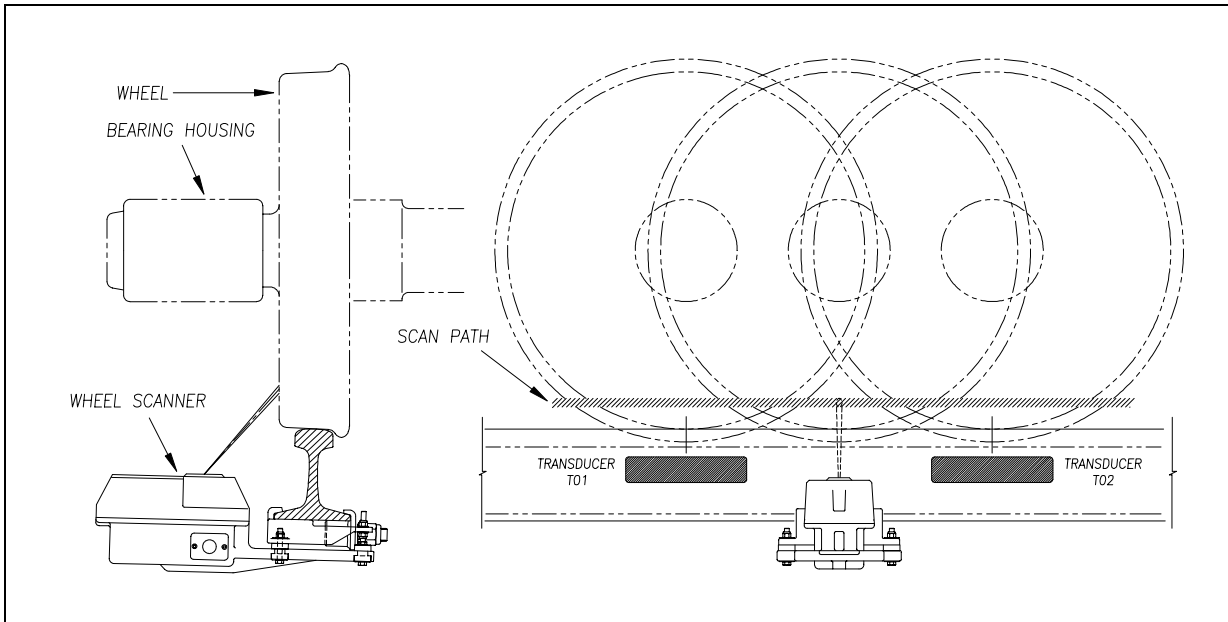

Type II Wheel Scanner

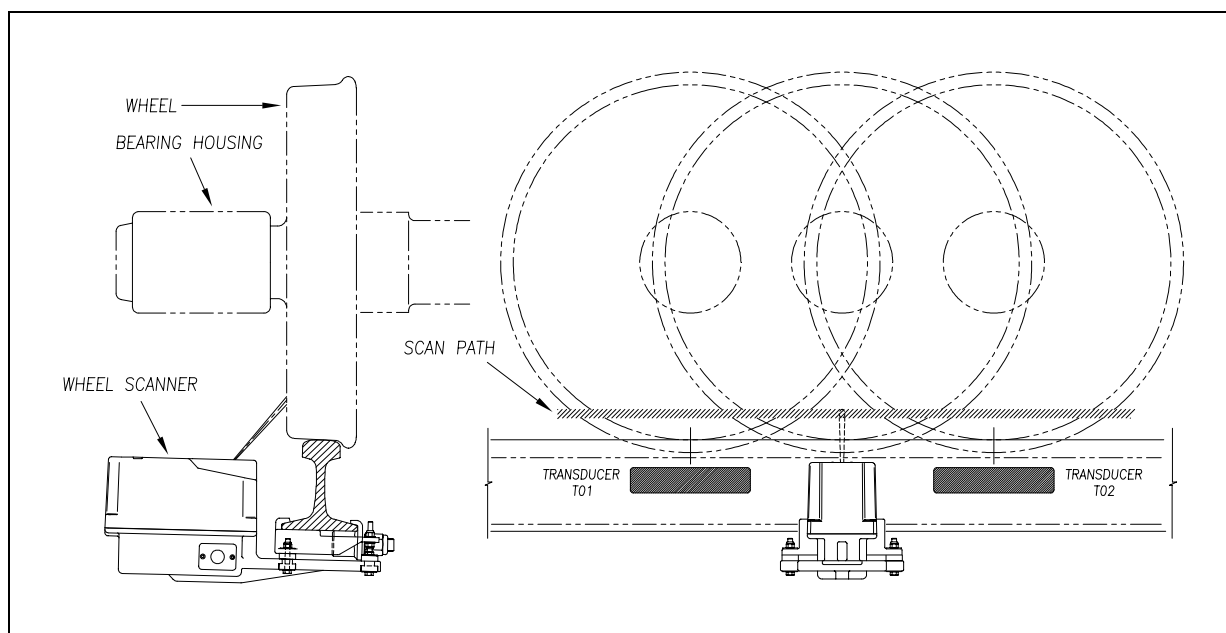

Type III Wheel Scanner

The SmartScanNG² system checks for hot wheels during the scanning process. Scan timing is controlled the same as for the bearing scanners.

Wheel scanning alarms are limited to absolute alarms only. To trigger a Hot Wheel alarm, wheel scanners must be properly installed, hot wheel detection must be enabled, and a wheel temperature must exceed the limit that was established using the Hot Wheel option on the Alarm Settings menu. This alarm limit is an offset, in degrees Fahrenheit, above the ambient temperature. Hot wheel detection is enabled using the Hot Wheel option on the Equipment Settings menu.

2.9 Auxiliary Alarms

The SmartScanNG² system can support input from as many as four external alarm devices. Any device that provides an open relay contact upon alarm detection can be supported by the system. Auxiliary alarms supported by the SmartScanNG² system are:

Dragging Equipment. To trigger a Dragging-Equipment alarm, a dragging-equipment detector must be properly installed, dragging-equipment detection must be enabled, and the SmartScanNG² system must sense an open relay contact from the dragging-equipment detector. Dragging-equipment detection is enabled using the Dragger option on the Equipment Settings menu.

High Load (oversized loads). To trigger a High-Load alarm, a high-load detector must be properly installed, high-load detection must be enabled, and the SmartScanNG² system must sense an open relay contact from the high-load detector. High-load detection is enabled using the High-Load option on the Equipment Settings menu.

When a high-load detector is configured for tripwire operation, the SmartScanNG² system only records one High-Load alarm, regardless of the high-load signal status. This is because you can only break a wire once.

When a high-load detector is configured for light-beam operation, the SmartScanNG² system records every High-Load alarm that occurs. This involves a caveat that the system won't flag High-Load alarms on consecutive axles. At least one unalarmed axle must separate the alarmed axles. Regardless of the number of detected High-Load alarms, it only announces a maximum of two.

The mode of operation (light beam or tripwire) isn't relevant when the SmartScanNG² system finds a Stuck High-Load Detector Pretrain alarm. When this occurs, the system flags the pretrain condition as an integrity failure, disables high-load scanning for the remainder of the train, and doesn't assign a high-load condition to any of the axles.

Wide Load (shifted loads). To trigger a Wide-Load alarm, two wide-load detectors (one on each side of the track) must be properly installed, wide-load detection must be enabled, and the SmartScanNG² system must sense an open relay contact from either of the wide-load detectors. Wide-load detection is enabled using the Wide-Load option on the Equipment Settings menu.

When a wide-load detector is configured for tripwire operation, the SmartScanNG² system only records one Wide-Load alarm, regardless of the wide-load signal status. This is because you can only break a wire once.

When a wide-load detector is configured for light-beam operation, the SmartScanNG² system records every Wide-Load alarm that occurs. This involves a caveat that the system won't flag Wide-Load alarms on consecutive axles. At least one unalarmed axle must separate the alarmed axles. Regardless of the number of detected Wide-Load alarms, it only announces a maximum of two.

The mode of operation (light beam or tripwire) isn't relevant when the SmartScanNG² system finds a Stuck Wide-Load Detector Pretrain alarm. When this occurs, the system flags the pretrain condition as an integrity failure, disables wide-load scanning for the remainder of the train, and doesn't assign a wide-load condition to any of the axles.

Both high-load detectors and wide-load detectors must be either tripwire detectors or light-beam detectors. The selection of a tripwire or light beam is made using the Clearance Type option on the Equipment Settings menu.

3.0 Display Panel

Located on the front of the SmartScanNG² Controller Module is the Display Panel. Its status indicators and display module provide a snapshot of the overall system health. As a convenience, the Display Panel also provides a user interface to execute some frequently used system functions (i.e., Auto Cal, Radio Test, etc.).



SmartScanNG² Display Panel

3.1 LED Indicators

There are six LED status indicators located above the OLED display.

LED	Meaning when Lit
TO1	Indicates wheel sensor TO1 is active.
TO2	Indicates wheel sensor TO2 is active.
COP-A	Indicates the status of Processor-A. If the CPU is running its program correctly, the LED blinks on and off. If the program isn't operating as expected, the LED is lit solid or isn't lit at all.
COP-B	Indicates the status of Processor-B. If the CPU is running its program correctly, the LED blinks on and off. If the program isn't operating as expected, the LED is lit solid or isn't lit at all.
PTT	Indicates the radio PTT is active.

SYS WARN	Indicates that a system warning has been detected. To turn off the SYS WARN LED from the keypad, select the Sys. Health Menu and use the "Reset Sys. Health" option. From the Serial Interface, navigate to Main Menu - System Functions Menu - Maintenance Menu and use the "Reset System Health" option. Using either method turns off the LED and resets the maintenance counter. The detector begins evaluating new maintenance statistics as trains pass the site.
----------	---

3.2 Keypad & Display

The display assembly includes a 4-line, 20-character OLED display and a five-key membrane switch panel. If unused for five minutes, the display times out to conserve power. Press any key to turn the display back on.

Keypad Switch	Function
FUNC	The function key toggles from the home screen (described below) to the Main Menu. It also serves as a "Back" key in the system submenus to return to the previous menu level.
▼ (Arrow Down)	Scroll down the menu options.
▲ (Arrow Up)	Scroll up the menu options.
SELECT	Selects the highlighted menu option.
RESET	Initiates system reset.

The home screen displays the milepost, time, and temperature.

MP 1234.5	02:05:39
	Temp: 72

If a system warning has been detected, the display will indicate "Check System Health" at the bottom of the screen.

Menu Navigation:

- Press the **FUNC** key to toggle from the home screen to the Main Menu or to back out of the submenus.
- Use the **▲UP** and **▼DOWN** keys to move the **▶** pointer next to the desired menu option.
- Press the **SELECT** key to choose the menu option. The "↓" symbol on the display screen indicates that there are more options available if you scroll down. Likewise, the "↑" symbol indicates more options are available if you scroll up.

```
Main Menu
▶ Sys. Health Menu
  Reset Sys. Health
↓ Radio Test
```

3.3 System Functions

Several system functions can be performed from the display panel. Available options are:

- System Health Menu
- Radio Test
- Scanner Cal. Menu
- Network Menu
- Radio IO Status
- Volume Menu
- System IO Status
- Test Train
- Tag Reader Test
- Efficiency Test

3.3.1 System Health Menu

System Health Menu options are not available at the time of this publication.

3.3.2 Radio Test

To perform a radio test, go to the Main Menu and select **Radio Test**

```
Main Menu
↑▶ Radio Test
  Scanner Cal. Menu
↓ Network Menu
```

The Radio Test option is used to broadcast a short message through both the speaker and the radio. Using this option lets you verify that the speaker and radio are working properly.

At single-track sites, the text of the message is usually "Testing, U P Detector, milepost (milepost number), testing, one, two, three, four, five, four, three, two, one, testing, detector out." At multitrack sites, the text of the message is usually "Testing, U P Detector, milepost (milepost number), track (track designation), testing, one, two, three, four, five, four, three, two, one, testing, detector out."

If the system isn't currently making any other voice announcements, it begins the Radio Test announcement.

If the system is currently making a voice announcement, the radio test begins after the announcement.

While listening to the message, look at the PTT LED on the display panel.

The **PTT LED** should be lit. If this LED isn't lit, the system's ability to send a message to the radio might be inhibited by the Radio Inhibit option on the System Functions menu. If the radio is inhibited, the results of this check are invalid.

3.3.3 Scanner Cal. Menu

The SmartScanNG² system self-calibrates its pyrometer interface circuitry. You need only put a preheated calibrated heat source on a scanner and place the system in autocalibration mode. The system then scans all pyrometer inputs until the signal from the calibrated heat source is located. The necessary adjustments to the related interface circuitry are automatically made while the system monitors its own progress by analyzing changes in the heat signals.

From the Main Menu, select **Scanner Cal. Menu**. This prompt appears.

```
Scanner Cal. Menu
▶N Rail: Type III
  S Rail: Type III
↓ N Wheel: Type III
```

Select an individual scanner to change the scanner type or Auto Cal to begin searching for heat on all scanners. Once the procedure has been completed, the autocalibration mode is disengaged, and the calibration results are displayed.

For a detailed description of the auto-calibration procedures, go to **Appendix E Calibrating of Type II Scanners** or **Appendix F Calibrating of Type III Scanners**.

3.3.4 Network Menu

From the Main Menu, select the **Network Menu** option to view/change network settings.

Available options are:

- Wi-Fi (on/off)
- IP Address
 - Ethernet address
 - Wi-Fi
- DHCP (on/off)
- TELNET port
- HTTP port
- HTTPS port
- Laptop Direct

When in Laptop Direct mode, the NG²'s Ethernet port is configured in such a way that a user can connect the NG² and their notebook computer with a single network cable and access the NG²'s telnet and web interfaces using www.wired.stc or 192.168.3.4. "Laptop Direct" mode uses the NG²'s built-in DHCP server. To avoid potential IP address conflicts, "Laptop Direct" mode polls every five seconds for the existence of other DHCP servers on the network attached to the Ethernet port. If another DHCP server is discovered, the "Laptop Direct" mode will shut down.

3.3.5 Radio IO Status

From the Main Menu, select Radio IO Status to view the radio screen. This screen will display certain radio status information such as:

- "PTT Disabled" if Radio Inhibit is active
- "Holdoff Active" if holdoff is enabled
- "CD active" when radio has detected an active carrier signal

Press SELECT key to initiate Radio Test.

3.3.6 Volume Menu

From the Main Menu, select **Volume Menu** to view/change speaker volume.

```
Vol: 5 [||||| ]
Up/Down = change
Select = Radio test
Func = Back
```

There are ten volume settings (0 – 9), with level 9 being the maximum volume. Press the ▲UP key to increase the volume level. Press the ▼DOWN key to decrease the volume level. With each change, the detector broadcasts the new volume setting at the new volume level. If an announcement is in progress, changes to the volume level occur in real-time.

Pressing the **SELECT** key initiates a radio test.

Use this option to verify that the speaker volume is at a sufficient level. "Press the **FUNC** key to exit the menu.

3.3.7 System IO Status

The System IO Status function is a useful tool for the diagnostic testing of inputs. From the Main Menu, select **System IO Status** to monitor inputs.

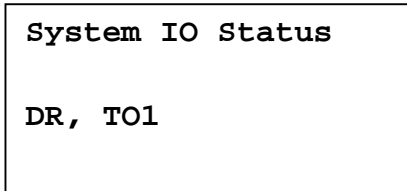

There are thirteen inputs monitored. Inputs appear on screen only while they are active. If no inputs are active, "None" appears. Available inputs are:

TO1, TO2, TC (presence), A1 (advance1), A2 (advance2), S1 –S4 (spare1 thru spare4), DR (dragger), HI (hi load), W1 (wide1), and W2 (wide2).

3.3.8 Test Train

In Test Train mode, the system opens all the shutters and simulates transducer pulses. During this time, a person can check various aspects of the installed components. The train is marked as a test train. There won't be any voltage (simulated heat) applied to the scanner inputs.

This test gates 256 simulated axles. During a test train, the TO1 & TO2 LEDs on the Display Panel will flash with each simulated axle.

From the Main Menu, select **Test Train** to initiate the test.

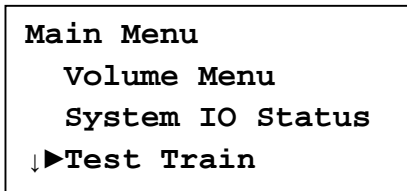

This prompt will appear:



Followed by this prompt:

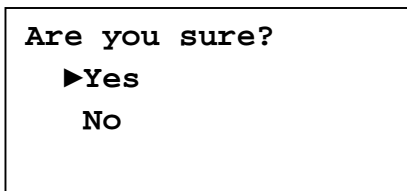

Choosing **Yes** broadcasts all Test Train announcements over the radio. Choosing **No** does not broadcast Test Train announcements over the radio.

3.3.9 Tag Reader Test

Tag Reader Test mode is a diagnostic tool used to verify reader functionality. Activating this test will turn on RF power to the AEI antennas for a period of two minutes. Placing an AEI test tag in the antenna's read-zone during the test should result in a single beep from the speaker when the tag is successfully read and validated. For further verification, the tag data will be transmitted via the serial communications port to your connected laptop.

From the Main Menu, select **Tag Reader Test**.

```
Main Menu
↑ System IO Status
  Test Train
↓▶ Tag Reader Test
```

This prompt will appear:

```
Tag Reader Test
Select to Start

Press Func to Exit
```

Press the Select key to begin the test. A timer appears on the display, counting down from two minutes.

```
Tag Reader Test
                               1:59

Press Func to Exit
```

3.3.10 Efficiency Test

The Efficiency Test is used to monitor train crew performance during a hotbox or dragging-equipment stop. When armed, the system generates an alarm on the next train and at the car number specified.

From the Main Menu, select **Efficiency Test** to configure and arm the test.

```
Main Menu
  Test Train
  Tag Reader Test
  ↓►Efficiency Test
```

This prompt appears:

```
Efficiency Test Menu
►Armed:           No
  Car Number:     1
  Alarm:          Dragger
```

Use the Alarm and Car Number options to select the type of alarm generated and the car number on which to place the alarm. With the alarm configuration complete, use the Arm option to arm the test. The firmware reads the Efficiency Test settings only when arming the test, so the desired car number and alarm type must be set before arming the test.

Select Armed. This prompt appears:

```
Arm? Are you sure?

►Yes
  No
```

CAUTION!

Unless authorized to do so, do not arm this function. Doing so will stop a train.

4.0 Serial Interface

The serial interface allows **on-site** and **off-site** communication with the system. This interface is one of two methods available for viewing reports and modifying system parameters. The other method is the Web interface.

Most sites are equipped with Ethernet service that provides remote communications capabilities. If not, you cannot communicate with the system **off-site**.

To use the interface locally, you need:

- A computer
- Communications software, which is installed on the computer
- A cable from the computer to a communications port on the Controller module

For remote access via network:

- A computer with communications software and internet connectivity
- An Ethernet connection at the SmartScanNG² controller

This section describes the serial interface for the Union Pacific SmartScanNG² system. It covers how to enter or change the system parameters. It is necessary to go through a complete setup the first time a SmartScanNG² system is installed at a new site. (If this is a double-track site, you also need to do this for the other SmartScanNG² system.) After that, the processor (in the Controller module) retains the setup information in flash memory. During a power outage, no setup information is lost.

4.1 Main Menu

- 1 For **off-site** connections, skip to Step 5.
- 2 If **on-site**, plug your computer into COM1.

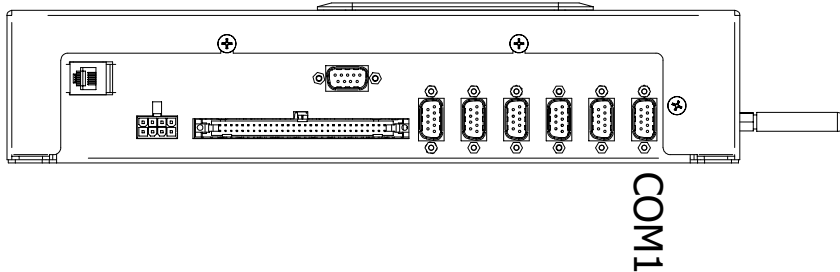

- 3 Turn on your computer.
- 4 Be sure that your computer has installed communications software, that it is set to use full-duplex, and that the baud rate is set to the appropriate setting (factory default is 19,200).

Use your communications software to open a LOG file and capture the whole session to the file. When your session is complete, you may then view what you have done with an editor, print it with a printer, or store it for later retrieval.

- 5 On your computer, open a LOG file, then initiate a remote connection to the site.

To display the **Main Menu**:

- 6 Press **[Esc]**.

If the system has been set up with security passwords, this prompt appears.

```
Enter password:
```

- 7 Type the appropriate password to display the Main Menu.

System login with an administrative password allows access to all system menus. System login with a user password allows the printing of reports only. The User password does not allow access to the Setup, Security, or System Functions menus.

NOTE: For situations where field personnel do not know the passwords required to access a detector, the NG² provides a backdoor. Typing "RECOVERY" at the password prompt will erase the current Admin and User passwords and replace them with the UP-defined default passwords. If the user does not know the default passwords, he will have to contact the UP SOC desk for that information.

8 The Main Menu appears.

```
Main Menu - Comm
-----
[A] - Train Summary
[B] - Train Detail
[C] - Exception Summary
[D] - Exception Detail
[E] - System Status Report
[F] - Last Train
[G] - Range of Trains
[H] - Train DSRs
[I] - AEI Diagnostic
[J] - Setup
[K] - Event Log
[L] - System Functions Menu
[M] - Replay Train
[N] - Security Menu
[X] - Exit
```

By selecting an option at the above prompt, you can:

- Produce a report.
- Replay an EOT announcement.
- Access the Setup menu from which you can set system parameters.
- Access the System Functions menu from which you can perform a radio test, run a test train, start the scanner calibration process, review system maintenance information, etc.

If a train is at the site when the Main menu is generated, "*** Train Is Present ***" is displayed just above the menu header for the Main menu and for every other menu.

9 When done, close the LOG file.

10 To exit the serial interface and return the system to normal operation, type **X**.

4.2 Setup Menu

To display the Setup menu:

- 1 Be sure that the Main menu is displayed.

The Main menu looks like this.

```
Main Menu - Comm
-----
[A] - Train Summary
[B] - Train Detail
[C] - Exception Summary
[D] - Exception Detail
[E] - System Status Report
[F] - Last Train
[G] - Range of Trains
[H] - Train DSRs
[I] - AEI Diagnostic
[J] - Setup
[K] - Event Log
[L] - System Functions Menu
[M] - Replay Train
[N] - Security Menu
[X] - Exit
```

- 2 Select **Setup**.

If the Setup menu is password protected, this prompt appears.

```
You are not logged in with admin privileges
Enter password:
```

You are given one chance to type the correct password. If you don't type the correct password, the system returns to the Main menu.

If the password is less than 32 characters long, press **[Enter]** after typing the last character. If the password is the full 32 characters in length, pressing **[Enter]** isn't necessary.

```
Setup Menu
-----
[A] - Date and Time
[B] - Site ID ..... NONAME
[C] - MP/KP
[D] - Track Designation ..... Single
[E] - Track Direction ..... E/W
[F] - Alarm Settings
[G] - Equipment Settings
[H] - Messages Settings
[I] - AEI Settings
[J] - Load Default Setup Parameters
[K] - COM Port Settings
[L] - Network Settings
[M] - Talker Mode ..... Talk Freely
[N] - Velocity ..... Enabled
[O] - Wind Settings
[X] - Exit
```

To access any of the Setup menu options, type the letter that corresponds to the desired menu option.

At any prompt, a timeout mechanism is in place to prevent the system from remaining in that state indefinitely. When a timeout occurs, the serial interface automatically disconnects. The timeout is set for 10 minutes for telnet connections and 20 minutes for serial connections.

If a train is at the site when the Setup menu is generated, "**** Train Is Present ****" is displayed just above the menu header for the Setup menu.

3 To return to the Main menu, type **X**.

If you've made setup changes, when you exit the menu, you will be prompted with:

"This will save the settings. Please type 'setup' to save settings. Press escape to abandon changes."

Changes to the system parameters aren't reflected until after you have exited the Setup menu.

4.2.1 Date and Time

To set or change the date, the time, or both:

- 1 Be sure that the Setup menu is displayed.

The Setup menu looks like this.

```
Setup Menu
-----
[A] - Date and Time
[B] - Site ID ..... NONAME
[C] - MP/KP
[D] - Track Designation ..... Single
      .
      .
      .
```

- 2 Select the Date and Time option.

A prompt like this appears.

```
Current Date: 02/11/2025
Enter New Date (mm/dd/yyyy):
```

Dates are in **mm/dd/yyyy** format, where **mm** is month, **dd** is day, and **yyyy** is year. Type the current date. You must include slashes. For days and months from 1 through 9, you must type leading zeros. Thus, for 18 July 2025, type **07/18/2025**.

If you want to keep the displayed date, press **[Enter]**. If you don't, type a new date.

- 3 Type a new date or press **[Enter]**.

A prompt like this appears.

```
Current time is: 22:47:34
Enter new time:
```

Time is in 24-hour **hh:mm:ss** format, where 8 a.m. is 08:00:00, noon is 12:00:00, 8 p.m. is 20:00:00, and midnight is 00:00:00. Thus, for 17 seconds past 3:42 p.m., type **15:42:17**. You must include colons. For hours, minutes, and seconds from 0 through 9, type leading zeros.

If you want to keep the displayed time, press **[Enter]**. If you don't, type a new time.

- 4 Type a new time or press **[Enter]**.

A prompt like this appears.

```
Current Time Zone: Eastern
Enter New Time Zone (E-Eastern,C-Central,M-Mountain,P-Pacific):
```

If you want to keep the displayed time zone, press **[Enter]**. If you don't, type the letter that corresponds to the time zone you want.

- 5 Type the letter that corresponds to the time zone you want or press **[Enter]**.

A prompt like this appears, stating whether the daylight-saving-time adjustment is currently disabled or enabled. Daylight-saving time is the period during which clocks are set one hour ahead of local standard time.

```
Daylight Savings Time Enabled OK (Y/N)?
```

If disabled, all times throughout the year are in standard time. If enabled, all times from the second Sunday in March until the first Sunday in November are in daylight-saving time. All other times are in standard time. Any change takes effect immediately. Later, if enabled, at 2:00 a.m. on the second Sunday in March, the system will adjust the system's clock forward an hour to 3:00 a.m., and at 2:00 a.m. on the first Sunday in November, the system will adjust its clock backward to 1:00 a.m.

At this point, you can type **Y** (yes or **N** (no). Typing **N** doesn't change the displayed time.

- 6 If you want to modify the adjustment, type **N**.

Typing the letter **N** toggles between disabled or enabled. A message like this appears, stating whether the daylight-saving-time adjustment is now disabled or enabled.

```
Daylight Savings Time Disabled OK (Y/N)?
```

- 7 If you don't want to modify the daylight-saving-time adjustment, type **Y**.

- 8 Upon completion of the step above, you will be prompted to type the word "setup" to save any changes made.

4.2.2 Site ID

To set or change the site ID option:

- 1 Be sure that the Setup menu is displayed.

The Setup menu looks like this.

```
Setup Menu
-----
[A] - Date and Time
[B] - Site ID ..... NONAME
[C] - MP/KP
[D] - Track Designation ..... Single
      .
      .
      .
```

- 2 Select the Site ID submenu.

A prompt like this appears.

```
Enter the Site ID (limit 6 characters):
```

- 3 To keep the displayed site ID:

- a Press **[Enter]**.

The Setup menu reappears.

- b Skip the remaining step.

- 4 To change the displayed site ID, type the new ID. The ID has a maximum of six characters. If less than six, press Enter after the last character.

The Setup menu reappears.

4.2.3 Milepost/Kilometer Post (MP/KP)

To set or change the milepost/kilometer post (MP/KP) setting:

- 1 Be sure that the Setup menu is displayed.

The Setup menu looks like this.

```
Setup Menu
-----
[A] - Date and Time
[B] - Site ID ..... NONAME
[C] - MP/KP
[D] - Track Designation ..... Single
      .
      .
      .
```

- 2 Select the MP/KP option.

A prompt like this appears.

```
Enter the milepost in the form ####.# (use leading zeros):
```

MP/KP is in **nnnn.n** format. You must include the decimal point. If the desired MP/KP has less than five digits, type leading zeros. If the desired MP/KP is an integer, type a trailing zero. Thus, for MP/KP 30, type **0030.0**.

- 3 To keep the displayed MP/KP:
 - a Press **[Enter]**.
The Setup menu reappears.
 - b Skip the remaining step.
- 4 To change the displayed MP/KP, type the new five-digit MP/KP, including the decimal point.

The Setup menu reappears.

4.2.4 Track Designation

To set or change the track designation setting:

- 1 Be sure that the Setup menu is displayed.

The Setup menu looks like this.

```
Setup Menu
-----
[A] - Date and Time
[B] - Site ID ..... NONAME
[C] - MP/KP
[D] - Track Designation ..... Single
      .
      .
```

- 2 Select the Track Designation option.

A menu and prompt like this appears.

```
Select a track designation:  
[0] - Single  
[1] - 1  
[2] - 2  
[3] - 3  
[4] - 4  
[5] - 5  
[6] - 6
```

Change the track designation by typing the letter corresponding to the desired setting.

4.2.5 Track Direction

To change the track direction setting:

- 1 Be sure that the Setup menu is displayed.

The Setup menu looks like this.

```
Setup Menu  
-----  
[A] - Date and Time  
[B] - Site ID ..... NONAME  
[C] - MP/KP  
[D] - Track Designation ..... Single  
[E] - Track Direction ..... N/S  
:  
:
```

- 2 Select the Track Direction option. A prompt like this appears. Select between N/S and E/W.

```
Select Track Direction:  
[1] - N/S  
[2] - E/W
```

4.2.6 Alarm Settings

To set or change one or more of the alarm settings:

- 1 Be sure that the Setup menu is displayed.

The Setup menu looks like this.

```
Setup Menu
-----
[A] - Date and Time
[B] - Site ID ..... NONAME
[C] - MP/KP
[D] - Track Designation ..... Single
[E] - Track Direction ..... N/S
[F] - Alarm Settings
      .
      .
      .
```

- 2 Select the Alarm Settings menu.

A menu and prompt like this appears.

```
Alarm Settings
-----
[A] - Absolute ..... 190
[B] - Differential ..... 117
[C] - Hot Wheel ..... 900
[D] - Cold Journal Counter ..... 3
[E] - Cold Journal Temp ..... 10
[F] - Cold Res Counter ..... 3
[G] - Differential Enabled ..... Yes
[H] - Advanced
[X] - Exit
```

This menu option allows you to change the various alarm limits that affect system operations. The current setting for each limit is displayed. To change one of the alarm limit settings, start by typing the letter corresponding to the desired option.

- 3 To leave the Alarm Settings menu and return to the Setup menu:
 - a Type **X**.
The Setup menu reappears.
 - b Skip the remaining steps.

4 To change the displayed **Absolute-alarm limit** :

The number after the word Absolute is an offset in degrees Fahrenheit above ambient temperature. When a bearing temperature exceeds this value, the system generates an Absolute alarm. However, when the Hot Bearing option on the Equipment Settings menu is disabled, Absolute alarms aren't generated.

```
Alarm Settings
-----
[A] - Absolute ..... 170
[B] - Differential ..... 115
[C] - Hot Wheel ..... 698
      .
      .
      .
```

- a Select **Absolute** from the Alarm Settings menu.

This prompt appears.

```
Absolute alarm setting (default = 170)
Enter a value from 1 to 300:
```

If the new limit has less than three digits, type leading zeros to make it three digits long or press **[Enter]** after typing one or two digits.

- b To not change the limit, press **[Esc]** and return to the Alarm Settings Menu.
- c Type the new limit.

5 To change the displayed **Differential-alarm limit** :

The number after the word Differential is an offset in degrees Fahrenheit between rail1 and rail2. A bearing temperature is compared to the bearing temperature on the opposite end of the same axle. When the difference in temperatures exceeds the value on the screen, the system generates a Differential alarm. However, when the Differential Enabled option on the Alarm Settings menu is disabled or the Hot Bearing option on the Equipment Settings menu is disabled, Differential alarms aren't generated.

```
Alarm Settings
-----
[A] - Absolute ..... 170
[B] - Differential ..... 117
[C] - Hot Wheel ..... 698
      .
      .
      .
```

- a Select **Differential** from the Alarm Settings menu.

This prompt appears.

```
Differential alarm setting (default = 117)
Enter a value from 1 to 300:
```

If the new limit has less than three digits, type leading zeros to make it three digits long or press **[Enter]** after typing one or two digits.

- b** To not change the limit, press **[Esc]** and return to the Alarm Settings menu.
- c** Type the new limit.

6 To change the displayed **Hot Wheel-alarm limit** :

The number after the words Hot Wheel is an offset in degrees Fahrenheit above ambient temperature. When a wheel temperature exceeds this value, the system generates a Hot Wheel alarm. However, when the Hot Wheel option on the Equipment Settings menu is disabled, Hot Wheel alarms aren't generated.

```
Alarm Settings
-----
[A] - Absolute ..... 170
[B] - Differential ..... 115
[C] - Hot Wheel ..... 900
      :
      :
```

- a** Select Hot Wheel from the Alarm Settings menu.

This prompt appears.

```
Hot Wheel alarm setting (default = 900)
Enter a value from 1 to 900:
```

If the new limit has less than three digits, type leading zeros to make it three digits long or press **[Enter]** after typing one or two digits.

- b** To not change the limit, press **[Esc]** and return to the Alarm Settings menu.
- c** Type the new limit.

7 To change the setting for **Cold Journal Counter**:

The number after the words Cold Journal Counter is the maximum number (per railside) of consecutive trains having:

- Cold Rail alarms needed to generate a Successive Cold Rails Exceeded Integrity Failure.
- Equal Heats Test Failed alarms needed to generate a Max Equal Heat Test Failures Exceeded Integrity Failure.

```
      :
      :
      :
[D] - Cold Journal Counter ..... 3
[E] - Cold Journal Temp ..... 10
[F] - Cold Res Counter ..... 3
[G] - Differential Enabled ..... Yes
[H] - Advanced
[X] - Exit
```

- a Select **Cold Journal Counter** from the Alarm Settings menu.

This prompt appears.

```
Cold Journal Counter alarm setting (default = 3)
Enter a value from 1 to 9:
```

- b To not change the value, press **[Esc]** and return to the Alarm Settings menu.
- c Type the new value.

8 To change the displayed **Cold Journal Temperature**:

The number after the words Cold Journal Temp is an offset, in degrees Fahrenheit, above the ambient temperature. When no bearing on a given rail generates a delta temperature reading greater than or equal to this value, the system generates a Cold Rail alarm for the given rail. There is a different Cold Rail alarm for each rail. That is, there is a Cold North Rail alarm and a Cold South Rail alarm (or, depending on track direction, a Cold East Rail alarm and a Cold West Rail alarm).

```
      .
      .
      .
[D] - Cold Journal Counter ..... 3
[E] - Cold Journal Temp ..... 10
[F] - Cold Res Counter ..... 3
[G] - Differential Enabled ..... Yes
[H] - Advanced
[X] - Exit
```

- a Select **Cold Journal Temp** from the Alarm Settings menu.

This prompt appears.

```
Cold Journal Temp alarm setting (default = 10)
Enter a value from 1 to 30:
```

If the new value has less than two digits, type leading zero or press **[Enter]** after typing one digit.

- b To not change the value, press **[Esc]** and return to Alarm Settings.
- c Type the new value.

9 To change the displayed **Cold Resistor Counter**:

The number after the words Cold Res Counter is the maximum number (per rai1side) of consecutive trains, having Cold Resistor or Cold Wheel Scanner Resistor alarms required to generate a possible Integrity Failure. Under normal circumstances, cold resistor conditions represent System Alarms, not Integrity Failures. However, if the number of consecutive trains bearing identical Cold Resistor or Cold Wheel Scanner Resistor alarms equals or exceeds the Cold Res Counter option, the conditions become Successive Cold Resistors Exceeded Integrity Failures, or Successive Cold Wheel Resistors Exceeded alarms, respectively.

```
      .  
      .  
      .  
[F] - Cold Res Counter ..... 3  
[G] - Differential Enabled ..... Yes  
[H] - Advanced  
[X] - Exit
```

a Select **Cold Res Counter**.

This prompt appears.

```
Cold Res Counter alarm setting (default = 3)  
Enter a value from 1 to 9:
```

b To not change the value, press **[Esc]** and return to Alarm Settings.

c Type the new value.

10 To change the **Differential Enabled** setting:

This setting enables or disables Differential alarms which are generated when a bearing temperature exceeds the opposite side bearing temperature of the same axle by a differential amount established using the Differential option on the Alarm Limits submenu.

Select Differential Enabled setting to toggle between Yes and No.

```
      .  
      .  
      .  
[F] - Cold Res Counter ..... 3  
[G] - Differential Enabled ..... Yes  
[H] - Advanced  
[X] - Exit
```

11 To change **Advanced** alarm setting options:

Select the desired setting. After the prompt, enter a new value.

```
Alarm Settings (Advanced)
-----
[A] - Carside Slope ..... 2.55
[B] - Carside Minimum ..... 300
[C] - Res Test: Minimum Rail Avg .... 25
[D] - Res Test: Minimum Wheel Avg ... 28
[E] - Max Alarms ..... 6
[X] - Exit
```

12 Carside Slope: The number after the words Carside Slope is the slope value used when doing carside-slope calculation/analysis. Section 2.0 - Defect Detection describes the Carside Slope alarm process. In order for Carside Slope alarms to be processed, they must be enabled using the Carside Slope option on the Equipment Settings menu. (Note: the Hot Bearing option on the Equipment Settings menu also has to be enabled. If it isn't, the detector won't recognize Carside alarms).

Select the **Carside Slope** option to change the setting:

A prompt like this appears.

```
Carside Slope alarm setting (default = 2.55)
Enter a value from 0.01 to 2.55:
```

Type the new value, including the decimal point, or hit escape to return to the previous menu.

13 Carside Minimum: The number after the words Carside Minimum is a minimum offset (in degrees Fahrenheit) used when doing carside-slope calculation/analysis. If the Carside Slope option on the Equipment Settings menu is disabled during train passage, no carside-slope calculation/analysis is done, and thus, no Carside Slope alarms are generated. (Note: the Hot Bearing option on the Equipment Settings menu also has to be enabled. If it isn't, the detector won't recognize Carside alarms). **Section 2.0 - Defect Detection** describes the Carside Slope alarm process.

Select the **Carside Minimum** option to change the setting:

A prompt this like appears.

```
Carside Minimum alarm setting (default = 300)
Enter a value from 0 to 300:
```

Type the new value or hit escape to return to the previous menu.

14 Res Test: Minimum Rail Avg: The number after the words Res Test: Minimum Rail Avg is the value that the average heats for both bearings are tested against after a train leaves the site. During the post-train resistor test, if a read resistor value isn't greater than 76% of the required resistor value, two additional checks will be performed. The average heats for both bearings are tested against the value set by the Resistor Test Minimum Rail Average option. If the average heats are less than the value set by the Resistor Test Minimum Rail Average option, the system generates a Cold Resistor alarm. If the average heats are greater than or equal to this value, bearing temperatures are compared on an axle-by-axle basis. This second check determines if more than half of the temperatures read by the bearing scanner with the low-read resistor value are 70% or less than the temperatures read by the other bearing scanner on the same axle. If 50% or more of the axles are low, a Cold Resistor alarm is flagged. If not, a Cold Resistor alarm isn't flagged, but a Rail Resistor Test Overridden alarm is.

Select **Res Test: Minimum Rail Avg** option to change the setting:
A prompt like this appears.

```
Res Test: Minimum Rail Avg alarm setting (default = 25)
Enter a value from 0 to 300:
```

Type the new value or hit escape to return to the previous menu.

15 Res Test: Minimum Wheel Avg: The number after the words Res Test: Minimum Wheel Avg is the value that the average heats for both wheels are tested against after a train leaves the site. During the post-train resistor test, if a read resistor value isn't greater than 76% of the required resistor value, two additional checks will be performed. The average heats for both wheels are tested against the value set by the Resistor Test Minimum Wheel Average option. If the average heats are less than the value set by the Resistor Test Minimum Wheel Average option, the system generates a Cold Wheel Scanner Resistor alarm. If the average heats are greater than or equal to this value, wheel temperatures are compared on an axle-by-axle basis. This second check determines if more than half of the temperatures read by the wheel scanner with the low-read resistor value are 70% or less than the temperatures read by the other wheel scanner on the same axle. If 50% or more of the axles are different, a Cold Wheel Scanner Resistor alarm is flagged. If not, a Cold Wheel Scanner Resistor alarm isn't flagged, but a Wheel Resistor Test Overridden alarm is.

Select **Res Test: Minimum Wheel Avg** option to change the setting:
A prompt this like appears.

```
Res Test: Minimum Wheel Avg alarm setting (default = 28)
Enter a value from 0 to 900:
```

Type the new value or hit escape to return to the previous menu.

16 Max Alarms: The maximum number of Exception Alarms allowed on a train before generating an Integrity Failure alarm. The Maximum Exception Alarms Exceeded Integrity Failure is generated when the maximum number of Exception Alarms (defined by the Max Alarms option) is exceeded on a single train. This limit also controls the assignment of the Stuck Dragger alarm. The Stuck Dragger alarm is generated when the maximum number of consecutive axles (defined by the Max Alarms option) had Dragging-Equipment alarms during train passage.

Select the Max Alarms option to change the setting:

A prompt this like appears.

```
Max Alarms alarm setting (default = 6)
Enter a value from 1 to 11:
```

Type the new value or hit escape to return to the previous menu.

4.2.7 Equipment Settings

To set or change one or more of the equipment parameters:

- 1 Be sure that the Setup menu is displayed.

The Setup menu looks like this.

```
Setup Menu
-----
[A] - Date and Time
[B] - Site ID ..... NONAME
[C] - MP/KP
[D] - Track Designation ..... Single
[E] - Track Direction ..... E/W
[F] - Alarm Settings
[G] - Equipment Settings
      .
      .
      .
```

2 Select the Equipment Settings menu.

A menu and prompt like this appears.

```
Equipment Settings
-----
[A] - Dragger ..... Yes
[B] - High Load ..... No
[C] - Wide Load ..... No
[D] - Hot Wheel ..... Yes
[E] - AEI ..... No
[F] - Hot Bearing ..... Yes
[G] - Presence Hardware ..... Yes
[H] - Advance Transducers ..... No
[I] - Cold Rail Test ..... All trains
[J] - AC Power Off Monitor ..... Yes
[K] - Select Scanner Types
[L] - Advanced
[X] - Exit
```

The current setting for each menu option is displayed. For example, the screen above shows that Wide-Load alarm detection is active (YES). To change one of the settings, press the letter corresponding to the desired option. Except for the Scanner Type and Advanced options, all the options toggle or cycle between available settings.

3 To leave the Equipment Settings menu and return to the Setup menu:

a Press **[Esc]** or type **X**.

The Setup menu reappears.

b Skip the remaining steps.

4 To change the current **dragger** (dragging-equipment) setting:

The Equipment Settings menu shows whether Dragging-Equipment alarm detection is enabled (YES) or disabled (NO). When enabled, Dragging-Equipment alarms will be announced and stored. In the presence of a continuous Dragger signal, the system alarms consecutive axles. When the number of consecutive axles with Dragger alarms reaches the Max Alarms limit, the system flags the Stuck Dragger condition.

```
Equipment Settings
-----
[A] - Dragger ..... NO
[B] - High Load ..... NO
[C] - Wide Load ..... NO
      :
      :
```

a Select **Dragger** from the Equipment Settings menu.

The dragging equipment setting toggles between active (YES) and inactive (NO). The Dragger option on the Equipment Settings menu changes. The Equipment Settings menu reappears.

If you want Dragging-Equipment alarm detection to occur, be sure that YES appears after the word Dragger on the Equipment Settings menu.

b Return to Equipment Settings.

5 To change the current **High Load** setting:

The Equipment Settings menu shows whether High Load alarm detection is active (YES) or inactive (NO). When High-Load detection is active, if the Clearance Mode setting on the Equipment/Advanced menu is set to Multiplexed, the system will record and announce High-Wide alarms. When the Clearance Mode setting is set to Separate, the system will record and announce High Load alarms.

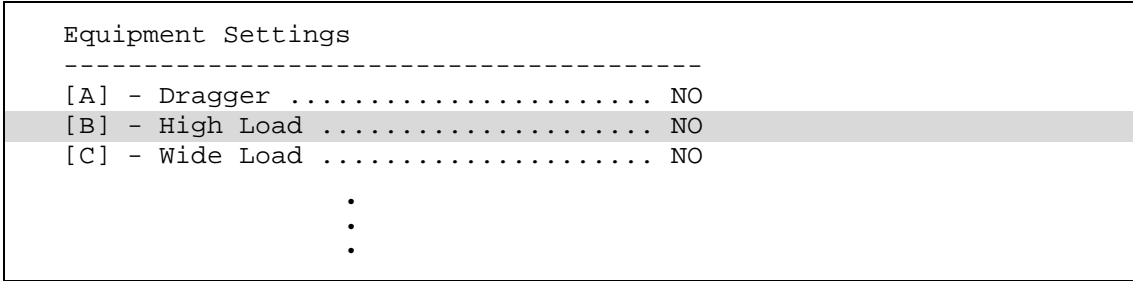

a Select **High Load** from the Equipment Settings menu.

The high-load setting toggles between active (YES) and inactive (NO). The High-Load option on the Equipment Settings menu changes. The Equipment Settings menu reappears.

If you want High-Load alarm detection to occur, be sure that YES appears after the word High-Load on the Equipment Settings menu.

b Return to Equipment Settings.

6 To change the current **Wide Load** setting:

The Equipment Settings menu shows whether Wide-Load alarm detection is active (YES) or inactive (NO).

a Select **Wide Load** from the Equipment Settings menu.

The wide-load setting toggles between active (YES) and inactive (NO). The Wide-Load option on the Equipment Settings menu changes. The Equipment Settings menu reappears.

If you want Wide-Load alarm detection to occur, be sure that YES appears after the word Wide-Load on the Equipment Settings menu.

b Return to Equipment Settings.

7 To change the current **Hot Wheel** setting:

The Equipment Settings menu shows whether Hot Wheel alarm detection is enabled (YES) or disabled (NO).

a Select from the Equipment Settings menu.

The Hot Wheel setting toggles between active (YES) and inactive (NO). The Hot Wheel option on the Equipment Settings menu changes. The Equipment Settings menu reappears.

b Return to Equipment Settings.

8 To change the **AEI** setting:

The Equipment Menu shows whether the AEI option is enabled (YES) or disabled (NO). When an AEI tag reader module and antennas are installed in conjunction with the NG², and the AEI option is enabled, the NG² will acquire the AEI identifiers from the vehicles in a passing train. These AEI identifiers will then be included in Train Detail reports and can be included in broadcast alarm messages. When the AEI option on the Equipment menu is disabled, the NG²'s interface to a tag reader will not be monitored.

a Select **AEI** from the Equipment Settings menu.

The setting toggles between active (YES) and (NO). The Equipment Settings menu reappears.

b Return to Equipment Settings.

9 To change the **Hot Bearing** setting:

The Equipment Settings menu shows whether Hot Bearing alarm detection is enabled (YES) or disabled (NO). Hot Bearing alarms include Absolute, Differential, Carside Slope, and Pyro Saturation alarms.

a Select **Hot Bearing** from the Equipment Settings menu.

The hot bearing setting toggles between active (YES) and inactive (NO). The Equipment Settings menu reappears.

b Return to Equipment Settings.

10 To change the **Presence Hardware** setting:

The Equipment Menu shows whether the Presence Hardware option (track circuit) is enabled (YES) or disabled (NO). When the Presence Hardware option is disabled, the NG² will ignore the Presence input to the system. When the Presence Hardware option is enabled, the NG² monitors the system's presence input for an indication of train presence.

a Select **Presence Hardware** from the Equipment Settings menu.

The Presence Hardware setting toggles between active (Yes) and inactive (No). The Equipment Settings menu reappears.

b Return to Equipment Settings.

11 To change the **Advance Transducer** setting:

The Equipment Menu shows whether the Advance Transducer option is enabled (YES) or disabled (NO). When the Advance Transducer option is disabled, the NG² will ignore the advance transducer inputs to the system. When the Advance Transducer option is enabled, the NG² will monitor the system's advance transducer inputs for an indication of train presence.

a Select **Advance Transducer** from the Equipment Settings menu.

The Advance Transducer setting toggles between active (YES) and inactive (NO). The Equipment Settings menu reappears.

b Return to Equipment Settings.

12 To change the **Cold Rail Test** setting:

The Equipment Menu shows whether the detector performs post-train cold-rail and equal-heat tests for all trains (All Trains) or only trains having at least 50 axles (Long Trains Only).

a Select **Cold Rail Test** from the Equipment Settings menu.

The setting toggles between **All Trains** and **Long Trains Only**. The Equipment Settings menu reappears.

b Return to Equipment Settings.

13 To change the **AC Power Off Monitor** setting:

The Equipment Menu shows whether the detector monitors the VAC power applied to the scanners.

a Select **AC Power Off Monitor** from the Equipment Settings menu.

The AC Power Off Monitor setting toggles between active (YES) and inactive (NO). The Equipment Settings menu reappears.

b Return to Equipment Settings.

14 To **Select Scanner Types**:

The Equipment Menu shows the scanner type currently selected for each scanner position.

a Select Scanner Types option from the Equipment Settings menu.

```
Scanner Types (changes require calibration)
-----
[A] - North Rail: Type III
[B] - South Rail: Type III
[C] - North Wheel: Type III
[D] - South Wheel: Type III
[X] - Exit
```

Select scanner options to cycle between **Type I**, **Type III** and **Type II**.

Type X to return to the Equipment Settings menu.

b Return to Equipment Settings.

15 To change **Advanced** settings:

- a** Select **Advanced** from the Equipment Settings menu.

```
Equipment Settings (Advanced)
-----
[A] - Carside Slope ..... No
[B] - Clearance Type ..... Trip Wire
[C] - Clearance Mode ..... Multiplexed
[D] - Winter Cycle ..... Jan - Jan
[E] - Gate Distance ..... 24.0 in
[F] - Dragger Debounce Time ..... 100 ms
[G] - Pre Train Dragger Dist ..... 0 ft
[H] - Pre Train High/Wide Dist ..... 0 ft
[I] - Presence Timeout Period ... 10 sec
[J] - System Voltage ..... 24v
[K] - Sunshot Menu
[L] - Transducer / Scanner Offset Menu
[N] - Carrier Detect Active State .. Low
[X] - Exit
```

16 To change the current **carside-slope** setting:

The Equipment Settings (Advanced) menu shows whether Carside Slope alarm detection is enabled (YES) or disabled (NO). If disabled (NO) during train passage, no carside-slope calculation/analysis is done, and thus, no Carside Slope alarms are generated. (The Hot Bearing option on the Equipment Settings menu also has to be enabled. If it isn't, the detector won't recognize Carside alarms).

- a** Select **Carside Slope** from the Equipment Settings (Advanced) menu.
The carside-slope setting toggles between active (YES) and inactive (NO). The option changes. The Equipment Settings (Advanced) menu reappears.
- b** Return to Equipment Settings (Advanced).

17 To change the current **clearance-type** setting:

The Equipment Settings (Advanced) menu shows whether clearance type is tripwire or light beam. This option is only used for high-load detectors and wide-load detectors. Both high-load detectors and wide-load detectors must be either tripwire detectors or light-beam detectors.

- a** Select **Clearance Type** from the Equipment Settings menu.
The clearance-type setting toggles between tripwire and light beam. The Clearance Type option on the Equipment Settings menu changes. The Equipment Settings (Advanced) menu reappears.
- b** Return to Equipment Settings (Advanced).

18 To change the current **clearance-mode** setting:

Configuring the detector's Clearance Mode parameter for Multiplexed operation requires that the Announce High Load and Announce Wide Load settings have matching values. Consequently, operating with a Clearance Mode setting of Multiplexed has the following operational effects:

- When switching the Clearance Mode parameter from Separate to Multiplexed, the firmware checks the current Announce High Load and Announce Wide Load settings. If they match, no changes occur. If they differ, the firmware changes both to Yes. In this situation, the following warning message appears on the Serial Interface.

```
*****
* When setting Clearance Mode to Multiplexed operation, the Announce High *
* Load and Announce Wide Load options will change to Yes (enabled) if *
* their current settings do not match. *
*****
```

With the Clearance Mode parameter set for Multiplexed operation, changing the Announce High Load or Announce Wide Load setting forces a matching change to the corresponding parameter's setting. In this situation, and depending on which parameter the user changed, a warning message similar to the following appears on the Serial Interface.

```
*****
* Clearance Mode is configured for Multiplexed operation. *
* Announce High Load changing to match Announce Wide Load. *
*****
```

The Equipment Settings (Advanced) menu shows whether clearance mode is separate or multiplexed. This option is only used for high-load detectors and wide-load detectors. When set to separate, the alarms coming from the high-load detectors are announced as High-Load alarms, and the alarms coming from the wide-load detectors are announced as Wide-Load alarms. When set to multiplexed, the alarms coming from the high-load detectors and wide-load detectors are announced as High-Wide alarms.

- Select **Clearance Mode** from the Equipment Settings (Advanced) menu.
The clearance-mode setting toggles between separate and multiplexed. The Clearance Mode option on the Equipment Settings menu changes. The Equipment Settings menu reappears.
- Return to Equipment Settings (Advanced).

19 To change the current **winter-cycle** setting:

The Equipment Settings (Advanced) menu shows whether the winter-cycle feature is enabled or disabled. To avoid errant heat readings caused by moisture on the pyrometer lenses, the scanners have heaters built into them. The heaters are made active, for varying periods of time, depending on the ambient temperature.

The table below lists the heater activation times for both normal and winter-cycle operation, grouped by ambient temperature.

Temperature Range in degrees Fahrenheit		Out of every ten seconds, the number of seconds the scanner heaters are active	
Low	High	Winter Cycle Disabled	Winter Cycle Enabled
--	16	4	8
17	35	3	7
36	51	2	2
52	80	1	1
80	--	Off	Off

The normal heater activation times aren't suitable for extremely cold climates, so the winter-cycle feature compensates for this. When this feature is disabled, the heater controls function normally. When enabled, the system increases the normal running time for the scanner heaters. The winter-cycle feature doesn't affect all the temperature ranges that the scanner heaters will activate on. It affects just the ones that are considered extremely cold.

- a** From the Equipment Settings (Advanced) submenu, select **Winter Cycle**.

The **Winter Cycle** option on the submenu changes.

If you disabled the winter-cycle setting, the Equipment Settings (Advanced) submenu reappears. If you enabled the winter-cycle setting, a prompt similar to this appears.

```
Choose a starting month and ending month. (Make them the same to
enable year-round.)
Starting month, currently: 10
New value (1-12):
```

If the new start value is one digit long, you can type a leading zero to make it two digits long, or you can press **[Enter]** after typing one digit.

- b** If you disabled the winter-cycle setting, skip the steps below and return to step **3**.
c To not change the starting and ending values, press **[Esc]** and return to step **3**.

d Type the new starting value.

If you type zero or a value greater than 12, an error message and prompt similar to this appear.

```
Invalid range specified
Starting month, currently: 10
New value (1-12):
```

If you type an acceptable value, a prompt similar to this appears.

```
Ending month, currently: 3
New value (1-12):
```

e If you get an error message, return to step **c**.

f To not change the ending value, press **[Esc]** and return to step **3**.

g Type the new ending value.

If you type zero or a value greater than 12, an error message and prompt similar to this appear.

```
Invalid range specified
Ending month, currently: 3
New value (1-12):
```

If you type an acceptable value, the Equipment submenu reappears, displaying the start and end months that the snow cycle is enabled. For example, if you typed 01 for the start month and 01 for the end month, you'll see a line like this.

```
Equipment Settings (Advanced)
-----
[A] - Carside Slope ..... No
[B] - Clearance Type ..... Trip Wire
[C] - Clearance Mode ..... Multiplexed
[D] - Winter Cycle ..... Jan - Jan
[E] - Gate Distance ..... 24.0 in
      .
      .
```

If you entered the same value (that is, the same month) for both the start and end months, the heaters are enabled year-round. For example, if the start month is 12 and the end month is 12, the heaters are enabled year-round. If the start month is 12 and the end month is 11, the heaters are also enabled year-round. If the start month is 11 and the end month is 12, the heaters are only enabled for November and December.

h If you get an error message, return to step **f**.

i Return to Equipment Settings (Advanced).

20 To change the current value for **gate distance** (aka gate width):

The Equipment Settings (Advanced) menu shows the number of inches between the centers of the gating transducers.

```
Equipment Settings (Advanced)
-----
[A] - Carside Slope ..... No
[B] - Clearance Type ..... Trip Wire
[C] - Clearance Mode ..... Multiplexed
[D] - Winter Cycle ..... Jan - Jan
[E] - Gate Distance ..... 24.0 in
      .
      .
      .
```

- a** Select **Gate Distance** from the Equipment Settings (Advanced) menu.

This prompt appears.

```
Gate Distance equipment setting (default = 24.0)
Enter a value from 18.0 and 48.0:
```

The gate distance is in **nn.n** format. You must type the decimal point. If the new value has less than three digits, type leading zeros, trailing zeros, or both. Thus, for 2, type **02.0**. The gate distance (it is usually 24.0) can be recorded in 1/10-inch increments to reflect the actual transducer spacing. Accurate gating-transducer spacing results in accurate speed calculations and train length calculations.

- b** Type the number in the **nn.n** format.

The Gate Distance option on the Equipment Settings (Advanced) menu changes. The Equipment Settings menu reappears.

- c** Return to Equipment Settings (Advanced).

21 The **Dragger Debounce Time** parameter defines the amount of time the Dragger signal must be active before the system flags a Dragger alarm. The detector ignores Dragger activations with durations shorter than this time limit. To change this parameter:

- a** Select **Dragger Debounce Time** from the Equipment Settings (Advanced) menu.

This prompt appears.

```
Dragger Debounce Time equipment setting (default = 100 ms)
Enter a value from 0 and 999:
```

If the new value has less than three digits, type leading zeros to make it three digits long or press [Enter] after typing one or two digits.

- b** Return to Equipment Settings (Advanced).

22 The **Pre Train Dragger** distance defines the amount of space in front of a train in which a detected dragger alarm is assigned to the first axle rather than as a pre-train alarm. To change the Pre Train Dragger Distance:

- a Select **Pre Train Dragger Dist** from the Equipment Settings (Advanced) menu.

This prompt appears.

```
Pre Train Dragger Dist equipment setting (default = 0 ft)
Enter a value from 0 and 15:
```

If the new value has less than three digits, type leading zeros to make it three digits long or press [Enter] after typing one or two digits.

- b Return to Equipment Settings (Advanced).

23 The **Pre Train High/Wide** distance defines the amount of space in front of a train in which a detected high-load alarm or wide-load alarm is assigned to the first axle rather than as a pre-train alarm. To change the Pre Train High/Wide Distance:

- a Select **Pre Train High/Wide Dist** from the Equipment Settings (Advanced) menu.

This prompt appears.

```
Pre Train High/Wide Dist equipment setting (default = 0 ft)
Enter a value from 0 and 15:
```

If the new value has less than three digits, type leading zeros to make it three digits long or press [Enter] after typing one or two digits.

- b Return to Equipment Settings (Advanced).

24 **Presence Timeout Period** defines the period of time that Presence must be inactive before a train is finalized and stored. To change the Presence Timeout Period:

- a Select **Presence Timeout Period** from the Equipment Settings (Advanced) menu.

This prompt appears.

```
Presence Timeout Period equipment setting (default = 10 sec)
Enter a value from 5 to 30:
```

- b Return to Equipment Settings (Advanced).

25 The **System Voltage** parameter should be set to match the voltage of the battery subsystem currently powering your SmartScanNG² (either 24V or 12V). This setting determines the battery levels used to flag Low Battery and Dead Battery conditions. To change this setting:

- a Select System Voltage to toggle between 24V and 12V settings.

- b Return to Equipment Settings (Advanced).

26 To view the Sunshot Menu:

Select **Sunshot Menu** from the Equipment Settings (Advanced) menu.

```
Equipment Settings (Advanced)
-----
[A] - Carside Slope ..... No
[B] - Clearance Type ..... Trip Wire
[C] - Clearance Mode ..... Multiplexed
[D] - Winter Cycle ..... Nov - Jan
[E] - Gate Distance ..... 24.0 in
[F] - Dragger Debounce Time ..... 100 ms
[G] - Pre Train Dragger Dist ..... 0 ft
[H] - Pre Train High/Wide Dist .... 0 ft
[I] - Presence Timeout Period ... 10 sec
[J] - System Voltage ..... 24v
[K] - Sunshot Menu
[L] - Transducer / Scanner Offset Menu
[N] - Carrier Detect Active State .. Low
[X] - Exit
```

27 To change the Sunshot Menu settings:

```
Sunshot Menu
-----
[A] - Sunshot Filter ..... Disabled
[B] - Bearing Scanner Orientation ..... 0 degrees
[C] - Latitude ..... 35.0456
[D] - Longitude ..... -85.3097
[E] - Print Sunshot Season
[X] - Exit
```

- a** Select the Sunshot Filter option to toggle from Enabled to Disabled.
- b** Select the Bearing Scanner Orientation option to change compass direction.

This prompt appears.

```
Bearing Scanner Orientation -
The compass direction in degrees that the scanners are facing.
Enter a value from 0 to 359:
```

- c** Select the Latitude option to change the value.

This prompt appears.

```
Latitude -
The geographic latitude of your site in degrees.
Enter a value from 0.0000 to 90.0000:
```

- d Select the Longitude option to change the value.

This prompt appears.

```
Longitude -  
The geographic longitude of your site in degrees.  
Enter a value from -180.0000 to 180.0000:
```

28 To view the Transducer / Scanner Offset Menu:

Select **Transducer / Scanner Offset Menu** from the Equipment Settings (Advanced) menu.

```
Equipment Settings (Advanced)  
-----  
[A] - Carside Slope ..... No  
[B] - Clearance Type ..... Trip Wire  
[C] - Clearance Mode ..... Multiplexed  
[D] - Winter Cycle ..... Jan - Jan  
[E] - Gate Distance ..... 24.0 in  
[F] - Dragger Debounce Time ..... 100 ms  
[G] - Pre Train Dragger Dist ..... 0 ft  
[H] - Pre Train High/Wide Dist .... 0 ft  
[I] - Presence Timeout Period ... 10 sec  
[J] - System Voltage ..... 24v  
[K] - Sunshot Menu  
[L] - Transducer / Scanner Offset Menu  
[N] - Carrier Detect Active State .. Low  
[X] - Exit
```

29 To change the Transducer / Scanner Offset Menu settings:

```
Transducer / Scanner Offset Menu  
-----  
[A] - Transducer Type ..... Frauscher  
[B] - Rail Size ..... 136 (67.46)  
[C] - Transducer Rail ..... Rail 1  
[D] - North Rail Scanner Offset ..... 22 inches (TO1)  
[E] - South Rail Scanner Offset ..... 22 inches (TO1)  
[F] - North Wheel Scanner Offset ..... 0 inches (TO1)  
[G] - South Wheel Scanner Offset ..... 0 inches (TO1)  
[X] - Exit
```

- a Select Transducer Type option to change the setting (toggles from Magnetic to Frauscher).

NOTICE!

When using Frauscher transducers, the settings for rail size and scanner offset MUST be entered in order for the system firmware to accurately calculate the “Virtual Gate” of each scanner. As depicted below, The scanner offset is measured from the center of the transducer bracket to the center of the scanner mounting bracket.

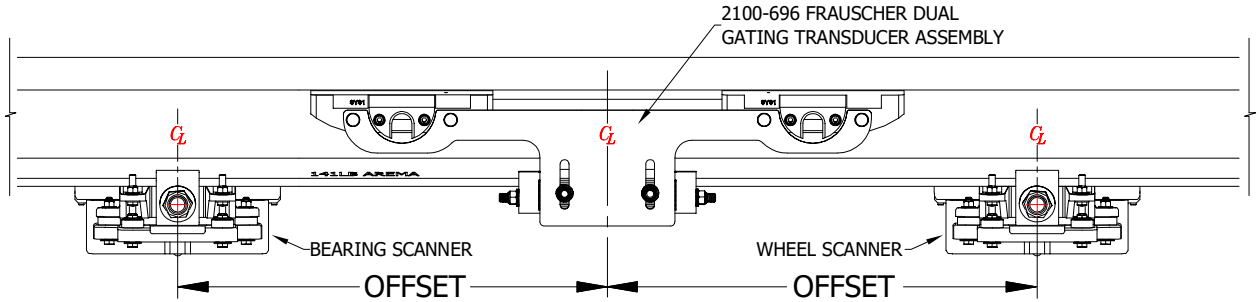

b To change the rail size, select the menu option. A prompt like this appears:

```
Select a Rail Size:
  lbs/yd (kg/m)
[A] - 100 (49.62)
[B] - 115 (57.05)
[C] - 122 (60.52)
[D] - 127 (63.00)
[E] - 132 (65.48)
[F] - 136 (67.46)
[G] - 141 (69.94)
```

Select the appropriate setting for your site.

c To set the Transducer Rail, select the menu option. A prompt like this appears.

```
Which rail are the transducers on?

[A] - Rail 1
[B] - Rail 2
```

Enter the appropriate option. The following warnings are displayed when “Track Direction” option gets modified.

```
*****
* Warning!
* Make sure the 'Track Direction' parameter is correct in the 'Setup' menu.
* The definitions of Rail-1 and Rail-2 here are dependent on
* the 'Track Direction' setting.
*****
```

- d To set the scanner offset value for each scanner, select the menu option. A prompt like this appears.

```
North Rail Scanner Offset transducer setting (default = 22 inches)
Enter an OFFSET value from 0 to 100 inches (round to nearest inch):
```

Enter the appropriate offset setting for each scanner to the nearest inch.

Next, you will be prompted to select scanner orientation (this information is also necessary for “Virtual Gate” calculations).

```
Is the scanner closer to T01 or T02?
[1] - T01
[2] - T02
```

Enter the appropriate selection.

- e Return to step 3.

30 To change the current **Carrier Detect Active State** setting:

The Equipment Settings (Advanced) menu indicates whether the Carrier Detect Active State is High or Low.

- a Select **Carrier Detect Active State** from the Equipment Settings menu.

The Carrier Detect Active State setting toggles between (High) and (Low). The Equipment Settings (Advanced) menu reappears.

- b Return to step 3.

4.2.8 Messages

To set or change any of the message parameters:

- 1 Be sure that the Setup menu is displayed.

The Setup menu looks like this.

```
Setup Menu
-----
      •
      •
      •
[G] - Equipment Settings
[H] - Messages Settings
[I] - AEI Settings
[J] - Load Default Setup Parameters
[K] - COM Port Settings
[L] - Network Settings
[M] - Talker Mode ..... Talk Freely
[N] - Velocity ..... COM 3
[O] - Wind Settings
[X] - Exit
```

2 Select the Messages menu

A menu and prompt like this appears. The options on the Messages menu are used to affect the phrases broadcast to a passing train or are used to modify the parameters associated with the rebroadcast function.

Messages Settings	

[A] - Axles	No
[B] - Speed	No
[C] - Temperature	No
[D] - Length	No
[E] - Slow	Yes
[F] - Power Off	Yes
[G] - Customer Name	Yes
[H] - Lft/Rt Alarm Ref	No
[I] - Car ID With Alarm	No
[J] - Advanced	
[X] - Exit	

Enabling one or more of the above-highlighted options generates the ancillary messages: A (axles), B (speed), C (temperature), D (length), E (slow), and F (power off). The other options of the Messages menu aren't used to generate ancillary messages.

3 Press **[Esc]** or type **X** to leave the Messages menu and return to the Setup menu:

4 To change the **announce-axles** setting:

The Messages menu shows whether the total axle count is to be part of (YES) or not part of (NO) post-train announcements.

a Select **Axles** from the Messages menu.

The announce-axles setting toggles between announce (YES) or not announce (NO). The Announce Axles option on the Messages menu changes. The Messages menu reappears.

b Return to Messages Settings.

5 To change the **announce-speed** setting:

The Messages menu shows whether the exit speed of the train is to be part of (YES) or not part of (NO) post-train announcements.

a Select **Speed** from the Messages menu.

The announce-speed setting toggles between announce (YES) or not announce (NO). The Announce Speed option on the Messages menu changes. The Messages menu reappears.

b Return to Messages Settings.

6 To change the **announce-temperature** setting:

The Messages menu shows whether the ambient temperature (taken at the site by the shielded temperature probe as the train leaves the site) is to be part of (YES) or not part of (NO) post-train announcements.

- a** Select **Temperature** from the Messages menu.

The announce-temperature setting toggles between announce (YES) or not announce (NO). The Announce Temperature option on the Messages menu changes. The Messages menu reappears.

- b** Return to Messages Settings.

7 To change the **announce-train-length** setting:

The Messages menu shows whether the train length is to be part of (YES) or not part of (NO) post-train announcements.

- a** Select **Length** from the Messages menu.

The announce-train-length setting toggles between announce (YES) or not announce (NO). The Announce Train Length option on the Messages menu changes. The Messages menu reappears.

- b** Return to Messages Settings.

8 To change the **announce-slow-train** setting:

The Messages menu shows whether a message indicating a slow train (one going 7 mph or slower) is to be part of (YES) or not part of (NO) post-train announcements.

- a** Select **Slow** from the Messages menu.

The announce-slow-train setting toggles between announce (YES) or not announce (NO). The Announce Slow Train option on the Messages menu changes. The Messages menu reappears.

NOTE: This announcement will not occur, regardless of speed or Slow option setting, if the train had a Dragger alarm.

- b** Return to Messages Settings.

9 To change the **announce-power-off** setting:

The Messages menu shows whether the power-off message is to be part of (YES) or not part of (NO) post-train announcements. The generation of this message depends on battery voltage, not AC power. It is generated whenever the voltage coming from the battery is less than 12.6 VDC (12V system) or 22.0 VDC (24V system). AC power need never have been off to cause this to happen. However, most times, it does indicate that AC power has been off, causing the battery to be drained.

- a** Select **Power Off** from the Messages menu.

The announce-power-off setting toggles between announce (YES) or not announce (NO). The Announce Power Off option on the Messages menu changes. The Messages menu reappears.

- b** Return to Messages Settings.

10 To change the **announce-customer-name** setting:

The Messages menu shows whether the customer's railroad name is to be part of (YES) or not part of (NO) of all announcements.

- a** Select **Customer Name** from the Messages menu.

The announce-customer-name setting toggles between announce (YES) or not announce (NO). The Announce Customer Name option on the Messages menu changes. The Messages menu reappears.

- b** Return to Messages Settings.

11 To change the **left-right-alarm-reference** setting:

The Messages menu shows whether the alarm reference is announced as left or right (YES) or as north, south, east, or west (NO).

- a** Select **Lft/Rt Alarm Ref** from the Messages menu.

The left-right-alarm-reference setting toggles between YES and NO. The Announce Left-Right Alarm Reference option on the Messages menu changes. The Messages menu reappears.

- b** Return to Messages Settings.

12 To change the **announce-car-identification** setting:

The Messages menu shows whether car-identification information is to be announced (YES) or not announced (NO). When this option is set to YES, and an Exception Alarm is found on a car, the car-identification information is included in the post-train announcement for the train having the Exception Alarm. This, of course, will only happen if the AEI option on the Equipment Settings menu is enabled (YES) and the AEI subsystem is functioning properly during train passage.

- a** Select **Car ID With Alarm** from the Messages menu.

The announce-car-identification setting toggles between enabled (YES) and disabled (NO). The Announce Car Identification option on the Messages menu changes. The Messages menu reappears.

- b** Return to Messages Settings.

13 Select **Advanced** to view or modify advanced message settings.

```
Message Settings (Advanced)
-----
[A] - Announce Hot Wheels ..... Yes
[B] - Announce Differential ..... Yes
[C] - Announce High Load ..... Yes
[D] - Announce Wide Load ..... Yes
[E] - Rebroadcast Time Limit .... 10 min
[F] - Rebroadcast DTMF Code ..... 001
[G] - Num Repeat No Defects ..... 1
[H] - EOT Repeat Delay ..... 1 sec
[X] - Exit
```

14 To change the **Announce Hot Wheels** setting:

The Messages Settings (Advanced) menu shows whether alarms are to be announced and/or for which train direction alarms will be announced. The Announce Hot Wheels option has four possible values:

- **“Yes”** alarm announcements are made for all detected alarms
- **“No”** alarm announcements are suppressed for all detected alarms. For all alarms detected, the word “suppressed” will be included in the alarm description printed on the Train Detail report.
- **“N/E Only”** alarm announcements will be made for trains traveling North or East but will be suppressed for trains traveling South or West. The word “suppressed” will be included in any alarm descriptions printed on Train Detail reports, for trains traveling South or West.
- **“S/W Only”** alarm announcements will be made for trains traveling South or West but will be suppressed for trains traveling North or East. The word “suppressed” will be included in any alarm descriptions printed on Train Detail reports, for trains traveling North or East.

a Select Announce Hot Wheels from the Messages Settings (Advanced) menu.

The Announce Hot Wheels setting toggles, in succession, between the values: Yes, N/E Only, S/W Only, No (and back to Yes again). The Messages Settings (Advanced) menu reappears.

b Return to Messages Settings (Advanced).

15 To change the **Announce High/Wide** setting:

The Messages Settings (Advanced) menu shows whether High Load and Wide Load alarms are to be announced and/or for which train direction High Load and Wide Load alarms will be announced. The Announce High/Wide option has four possible values:

- **“Yes”** High Load and Wide Load alarm announcements are made for all detected High Load and Wide Load alarms
- **“No”** High Load and Wide Load alarm announcements are suppressed for all detected High Load and Wide Load alarms. For all High Load and Wide Load alarms detected, the word “suppressed” will be included in the alarm description printed on the Train Detail report.
- **“N/E Only”** High Load and Wide Load alarm announcements will be made for trains traveling North or East but will be suppressed for trains traveling South or West. The word “suppressed” will be included in any High Load or Wide Load alarm description printed on Train Detail reports for trains traveling South or West.
- **“S/W Only”** High Load and Wide Load alarm announcements will be made for trains traveling South or West but will be suppressed for trains traveling North or East. The word “suppressed” will be included in any High Load or Wide Load alarm description printed on Train Detail reports for trains traveling North or East.

- a Select Announce High/Wide from the Messages Settings (Advanced) menu.

The Announce High/Wide setting toggles, in succession, between the values: Yes, N/E Only, S/W Only, No (and back to Yes again). The Messages Settings (Advanced) menu reappears.

- b Return to Messages Settings (Advanced).

16 To change the **Rebroadcast Time Limit** setting:

The Messages Settings (Advanced) menu shows a value for the Rebroadcast Time Limit setting. If a nonzero value is shown, the value is the number of minutes that you have to request a repeat of the last end-of-train (EOT) message. If zero is shown, the last EOT message is always available for rebroadcast. The train crew makes the actual request for rebroadcast. The repeated message has the word "rebroadcast" at the beginning and end of the message.

- a Select **Rebroadcast Time Limit**.

This prompt appears.

```
Rebroadcast Time Limit message setting (default = 10 min)
Enter a value from 0 to 240:
```

If the new limit has less than three digits, type leading zeros.

- b Type the three-digit value.

If you type 000, the last EOT message is always available for rebroadcast. If you type 240, the train crew has four hours (that is, 240 minutes) to request a repeat of the last EOT message.

- c Return to Messages Settings (Advanced).

17 To change the **Rebroadcast-DTMF-Code** setting:

The Messages Settings (Advanced) menu shows the rebroadcast-DTMF-code setting. The stored DTMF code contains the touchtone digits that trigger a rebroadcast. Up to ten digits may be entered into this setup parameter, including characters '#' and '*'. The SmartScanNG² system monitors radio traffic. When it receives the proper DTMF code, it will rebroadcast the last end-of-train message, provided the Rebroadcast Time Limit hasn't expired.

- a Select **Rebroadcast DTMF Code** from the Messages Settings (Advanced) menu.

This prompt appears.

```
Rebroadcast DTMF Code message setting (default = 001)
Enter a dtmf code (Esc to clear):
```

- b Type the new DTMF code or press **[Esc]**.

- c If you typed less than ten digits, press **[Enter]**.

The Rebroadcast DTMF Code option on the Messages Settings (Advanced) menu changes, and the Messages Settings (Advanced) menu reappears. If you typed only nondigits and then pressed **[Enter]**, the rebroadcast function would be turned off.

18 To change the **Num Repeat No Defects** setting:

The Messages Settings (Advanced) menu shows a value for how many times the No Defects announcement occurs. Valid values range from 1 to 3. When set to one, the No Defects announcement is spoken once. When set to three, the No Defects announcement is spoken three times.

- a** Select **Num Repeat No Defects** from the Messages Settings (Advanced) menu.

This prompt appears.

```
Num Repeat No Defects message setting (default = 1)
Enter a value from 1 to 3:
```

- b** Type a digit from 1 to 3.
- c** Return to Messages Settings (Advanced).

19 To change the **EOT Repeat Delay** setting:

The Messages Settings (Advanced) menu shows a value for how many seconds should elapse between EOT announcement repeats. Valid values range from 0 to 240.

- a** Select **EOT Repeat Delay** from the Messages Settings (Advanced) menu.

This prompt appears.

```
EOT Repeat Delay message setting (default = 1 sec)
Enter a value from 0 to 360:
```

If the new value has less than three digits, type leading zeros to make it three digits long or press **[Enter]** after typing one or two digits.

- b** To not change the value, press **[Esc]** and return to Messages Settings (Advanced).

4.2.9 AEI Reader Settings

The AEI reader parameters directly affect how the AEI readers operate to acquire tags while a train is passing the site.

To set or change any of the AEI reader parameters:

- 1** Be sure that the Setup menu is displayed.

The Setup menu looks like this.

```
      .
      .
[H] - Messages Settings
[I] - AEI Settings
[J] - Load Default Setup Parameters
      .
      .
```

2 Select **AEI Settings** to access menu options.

```
AEI Settings
-----
[A] - ID Separation ..... 2 IDs
[B] - Consecutive Reads ..... 2 Reads
[C] - RF Frequency (MHz) ..... 915.000
[D] - RF Attenuation (dB) ..... 0
[E] - Multi-Track Tag Filter .. Disabled
[F] - AEI Reader Interface
[G] - Tag Reader Test
[H] - Antenna 0 Offset .. 0 inches (T01)
[I] - Antenna 1 Offset .. 0 inches (T01)
[X] - Exit
```

ID Separation specifies the number of intervening tags that must be read and reported before a given tag is reported again. Valid values are 1, 2, 3, and 4. The default is 2.

Consecutive Reads specifies the number of times that a tag must be read before it is considered a valid (reportable) tag. Valid values are 1, 2, 3, and 4. The default is 2.

MPRR Frequency specifies the transceiver frequency of the MPRR reader.

MPRR Attenuation sets the RF attenuation in 1 dB increments over a range of 10 dB from a maximum output of 2 W at 0-dB attenuation to a minimum of 200 mW output at 10-dB attenuation.

The **Multi-Track Tag Filter**, when enabled, uses firmware algorithms to filter cross-track reads based on appended timestamps and tag data shared from adjacent SmartScanNG² systems.

The **AEI Reader Interface** allows for direct communication with the AEI tag reader and is used primarily for diagnostic purposes.

The **Tag Reader Test** allows the user to perform an on-sight functionality verification.

Antenna 0 Offset specifies the distance from the center of the scanning gate to the center of Antenna 0's read zone. The transducer in parenthesis is the gating transducer that is closest to antenna 0.

Antenna 1 Offset specifies the distance from the center of the scanning gate to the center of Antenna 1's read zone. The transducer in parenthesis is the gating transducer that is closest to antenna 1.

Selecting either of the offset menus will cause the following prompt to be presented.

```
Antenna 0 gate offset setting (default = 0 inches)

*** The OFFSET is the distance from the center of the scanning gate to the
*** center of the AEI antenna read zone.

Enter an OFFSET value from 0 to 240 inches: 120
Is the Antenna closer to T01 or T02? (Current setting is T01)
[1] - T01
[2] - T02
Setting value to 120.
Is the other antenna at the same offset? (Y/N)
Be sure to program in the offset of the other antenna.
```

3 To change the **ID Separation** parameter:

Select the **ID Separation** option to toggle from 1 to 2, from 2 to 3, from 3 to 4, or from 4 to 1.

4 To change the **Consecutive Reads** parameter:

Select the **Consecutive Reads** option to toggle from 1 to 2, from 2 to 3, from 3 to 4, or from 4 to 1.

5 Select the **MPRR Frequency** setting to change the operating frequency.

This message appears.

```
Select a frequency:
[A] - 903.750 MHz
[B] - 911.500 MHz
[C] - 915.000 MHz
[D] - 918.500 MHz
[E] - 921.500 MHz
```

Enter frequency selection. The AEI Reader Settings menu reappears.

6 Select **MPRR Attenuation** to attenuate the RF output signal.

This message appears.

```
MPRR Attenuation AEI setting (default = 0)
Enter a value between 0 and 10:
```

Enter a value "NN" (between 1 and 10), including leading zeros.

7 Select **Multi-Track Tag Filter** to toggle between **Enabled** and **Disable**.

When enabled, firmware algorithms are utilized to filter out cross-track reads.

8 To enter the **AEI reader interface**, select the option.

This message appears.

```
Entering AEI Reader commands
('EXIT' to quit)
```

9 To leave the AEI reader interface:

- a Type **EXIT** (case sensitive, all uppercase)
- b Press **[Enter]**.

10 To initiate the **Tag Reader Test**, select the option.

This message appears.

```
The Tag Reader Test will allow you to wave a tag in front of the
reader and the detector will produce an audible beep and print out
the tag information.
```

```
The detector will simulate a track circuit signal and energize the
antennas.
Afterwards the log will show a Train Canceled event.
```

```
Are you sure you want to continue? (y/n)
```

During the Tag Reader Test, data from AEI tags passed through the RF field will be displayed beneath this prompt.

11 To set the Antenna Offset, select the option (Antenna 0 Offset or Antenna 1 Offset).

This message appears.

```
Antenna 0 gate offset setting (default = 0 inches)
```

```
*** The OFFSET is the distance from the center of the scanning gate to the
*** center of the AEI antenna read zone.
```

```
Enter an OFFSET value from 0 to 240 inches:
```

Measure and enter the offset distance from the center of the scanning gate to the center of the antenna. If the measurement is other than zero, the following prompt will appear.

```
Is the Antenna closer to TO1 or TO2? (Current setting is TO1)
[1] - TO1
[2] - TO2
```

Enter the wheel sensor designator closest to the antenna (TO1 or TO2).

12 To leave the AEI Reader Parameters menu and return to the Setup menu, type **X**.

This prompt appears.

```
This will save the settings.
Please type 'setup' to save settings.
Press escape to abandon changes.
>
```

4.2.10 Load Default Setup Parameters

An option to load default setup parameters is intended to assist installers in setting up a new system. When this menu item is selected, the parameters listed below are assigned the values listed below. A "yes" after a parameter means that it is "enabled." A "no" means that it is "disabled."

Alarm Settings	

Absolute.....	170
Hot Wheel.....	900
Cold Journal Temp.....	10
Differential Enabled.....	Yes
Differential.....	117
Cold Journal Counter.....	3
Cold Res Counter.....	3
Alarm Settings (Advanced)	

Carside Slope.....	2.55
Res Test: Minimum Rail Avg.....	25
Max Alarms.....	6
Carside Minimum.....	300
Res Test: Minimum Wheel Avg.....	28
Equipment Settings	

Dragger.....	Yes
Hot Bearing.....	Yes
Wide Load.....	No
Presence Hardware.....	Yes
AC Power Off Monitor.....	Yes
Hot Wheel.....	Yes
High Load.....	No
AEI.....	No
Advance Transducers.....	No
Cold Rail Test Mode.....	All trains
Equipment Settings (Advanced)	

Carside Slope.....	No
Gate Distance.....	24.0 in
Pre Train Dragger Dist.....	0 ft
Presence Timeout Period....	10 sec
Clearance Mode.....	Multiplexed
Transducer Type.....	Frauscher
Transducer Rail.....	Rail 1
South Rail Scanner Offset..	22 (T01)
South Wheel Scanner Offset	0 (T01)
Winter Cycle.....	Jan - Jan
Dragger Debounce Time.....	100 ms
Pre Train High/Wide Dist.....	0 ft
System Voltage.....	24 V
Clearance Type.....	Trip Wire
Rail Size.....	136 (67.46)
North Rail Scanner Offset.....	22 (T01)
North Wheel Scanner Offset.....	0 (T01)
Carrier Detect Active State.....	Low
Message Settings	

Customer Name.....	Yes
Speed.....	Yes
Slow.....	No
Length.....	No
Car ID With Alarm.....	No
Axles.....	Yes
Temperature.....	Yes
Power Off.....	No
Lft/Rt Alarm Ref.....	No
Message Settings (Advanced)	

Announce Hot Wheels.....	Yes
Announce High Load.....	Yes
Rebroadcast Time Limit.....	10 min
Num Repeat No Defects.....	1
Announce Differential.....	Yes
Announce Wide Load.....	Yes
Rebroadcast DTMF Code.....	001
EOT Repeat Delay.....	1 sec
.	
.	
.	

•
•
•
Network Settings

Use Static Address..... No Static IP..... 192.168.1.99
Static Mask..... 255.255.255.0 Static Default Gateway..... 192.168.1.1
Static DNS Server..... 192.168.1.1 TELNET Port..... 23
FTP Port..... 21 HTTP Port..... 80
HTTPS Port..... 8080

Sunshots

Sunshot Filter..... Disabled Scanner Orientation..... 0
Latitude..... 35.0456 Longitude..... -85.3097
Dynamic Scan Window Start..... 10 Dynamic Scan Window End..... 38

Wind Settings

Wind Monitor..... Not Installed High Wind Alarm Limit..... 50 mph
Display Wind Diagnostics..... No Wind Poll Interval..... 15 sec
Slow Wind Speed Limit..... 2 mph Upper Interval Identical Limit..... 30 min
Lower Interval Ident Limit..360 min Wind Gust Interval..... 5 min
Suspicious Temp. Interval.. 720 min Re-enable Wind Updates..... 10 min
Wind Alarm Report Interval... 5 min

COM Port Settings

COM1 (Serial Interface)Baud 19200 N COM2 (Not Used)..... Baud 19200 N
COM3 (Velocity)..... Baud 19200 N COM4 (Not Used)..... Baud 19200 N
COM5 (AEI)..... Baud 19200 N COM6 (FlashHost)..... Baud 57600 N
RS485 (Wind Monitor)... Baud 9600 N Page Lines..... 0

AEI Settings

Tag Reader Type..... None ID Separation..... 2
Consecutive Reads..... 2 RF Frequency (MHz)..... 915.000
RF Attenuation (dB)..... 0 Multi-Track Tag Filter..... Disabled
Antenna 0 Offset..... 0 (TO1) Antenna 1 Offset..... 0 (TO1)

Scanner Calibration Date / Digital Potentiometer Settings

Rail 1 Type III... 05/16/2024 10:22 / 41 Rail 2 Type III..04/28/2024 08:07 / 40
Wheel 1 Type III... 04/28/2024 08:09 / 41 Wheel 2 Type III..04/28/2024 08:11 / 42

Resistor Baseline

Rail 1 Type III..... Valid Rail 2 Type III..... Valid
Wheel 1 Type III..... Valid Wheel 2 Type III..... Valid

To load the default setup parameters:

- 1 Be sure that the Setup menu is displayed.

The Setup menu looks like this.

```
      .  
      .  
      .  
[I] - AEI Settings  
[J] - Load Default Setup Parameters  
[K] - COM Port Settings  
[L] - Network Settings  
      .  
      .  
      .
```

- 2 Select **Load Default Setup Parameters**.

This prompt appears.

```
*****  
* Warning! You are about to load default setup parameters! *  
*****  
  
Are you sure? (y/n)
```

- 3 To not load default setup parameters:

Type **N**.

- 4 To load default setup parameters:

Type **Y**.

This message appears.

```
This will save the settings.  
Please type 'setup' to save settings.  
Press escape to abandon changes.  
>
```

Loading takes about a second. When finished, a prompt like this appears.

```
Saving settings  
Settings saved
```

4.2.11 COM1, COM2, COM3, COM4, COM6, & RS485

To change the parameters for serial port **COMx**:

- 1 Be sure that the Setup menu is displayed.

The Setup menu looks like this.

```
      .
      .
      .
[J] - Load Default Setup Parameters
[K] - COM Port Settings
[L] - Network Settings
      .
      .
      .
```

- 2 Select the **COM Port Settings** submenu to view options.

```
COM Port Settings
-----
[A] - COM1 (Serial Interface) 19200 None
[B] - COM2 (Not Used)..... 19200 None
[C] - COM4 (Not Used)..... 19200 None
[D] - COM6 (FlashHost)..... 57600 None
[E] - RS485 (Wind Monitor)... 9600 None
[F] - Page Lines ..... 0
[X] - Exit
```

- 3 Select the **COMx** option to edit current settings.

```
Uart Settings
-----
[A] - Baud Rate ..... 19200
[B] - Flow Control ..... None
[X] - Exit
```

- 4 Select **Baud Rate** to incrementally step through the selection options. Available settings are: 150, 300, 600,1200, 2400, 4800, 9600, 19200, 38400, 57600, and 115200.
- 5 Select **Flow Control** to incrementally step through the selection options. Available settings are None, HW (hardware), and SW (software).
- 6 The **Page Lines** parameter defines the number of lines the Serial Interface outputs before pausing and asking whether the user wants to continue, abort, etc. Setting this parameter to zero disables paging (reports print in their entirety without pausing).
- 7 To leave the **COM Port Settings** menu and return to the Setup menu, type **X**.

4.2.12 Network Settings

To change the **Network Settings**:

- 1 Be sure that the Setup menu is displayed.

The Setup Menu looks like this.

```
      :  
      :  
      :  
[L] - Network Settings  
[M] - Talker Mode ..... Talk Freely  
[N] - Velocity ..... COM 3  
[O] - Wind Settings  
[X] - Exit
```

- 2 Select the **Network Settings** menu.

A menu and prompt like this appears. To access/change any of the menu options, type the letter that corresponds to the desired setting.

```
Network Settings  
-----  
[A] - IP Settings  
[B] - HTTP Port ..... 80  
[C] - HTTPS Port ..... 8080  
[D] - FTP Port ..... 21  
[E] - TELNET Port ..... 23  
[F] - Load Default Network Settings  
[G] - Ping  
[H] - Display IP Addresses  
[X] - Exit
```

WARNING: Changes to any of the SmartScanNG² network settings **will not take effect** until after the system has been restarted. Before restarting the system, be certain that all changes have first been saved. After making any changes, you will be prompted to type in the word “setup” when you exit the Network Settings menu. This will save any changes made.

- 3 IP Settings** – This option provides a menu through which you can customize the IP parameters of the SmartScanNG²'s external Ethernet connection.

To view or change the SmartScanNG²'s IP settings, select the IP Settings option. The SmartScanNG² will display the following menu:

```
IP Settings
-----
[A] - Use Static Address ..... No
[B] - Static IP ..... 192.168.1.201
[C] - Static Mask ..... 255.255.255.0
[D] - Default Gateway ..... 192.168.1.1
[E] - DNS Server ..... 192.168.1.1
[X] - Exit
```

Use Static Address This parameter specifies whether the SmartScanNG² uses its configured Static IP address for external Ethernet communications (Yes), or retrieves its external IP address from a DHCP server (No).

Static IP This parameter specifies the IP address to use to connect to the SmartScanNG² when the Use Static Address option is set to Yes.

Static Mask This parameter specifies the subnet mask to use when the Use Static Address parameter is set to Yes.

Default Gateway This option specifies the address of the remote server/router through which communications with the SmartScanNG² will be routed.

DNS Server This parameter specifies the Domain Name Server that the SmartScanNG² can use for lookup services.

- 4 HTTP Port** This parameter is used to specify the TCP port number for the SmartScanNG²'s HTTP interface. This is the interface/port through which the SmartScanNG² serves its Web page interface.
- 5 HTTPS Port** This parameter is used to specify the port number for the SmartScanNG²'s secure HTTP interface.
- 6 FTP Port** This parameter is used to specify the TCP port number that the SmartScanNG² uses for communication via the FTP protocol.
- 7 TELNET Port** This parameter specifies the TCP port number that the SmartScanNG² uses for communication via the Telnet protocol. The SmartScanNG²'s serial-based menus are available through this port and protocol.

- 8 Load Default Network Settings.** To set the SmartScanNG²'s network parameters to their default configuration, select the Load Default Network Settings option from the Network Settings menu.

```
Network Settings
-----
[A] - IP Settings
[B] - HTTP Port ..... 80
[C] - HTTPS Port ..... 8080
[D] - FTP Port ..... 21
[E] - TELNET Port ..... 23
[F] - Load Default Network Settings
[G] - Ping
[H] - Display IP Addresses
[X] - Exit
```

This option presents a warning message and requires a Y/N confirmation before changing the parameters. Answering 'N' abandons the changes. Answering 'Y' proceeds to the standard prompt requiring the "setup" password to save the changes.

```
*****
* Warning! You are about to load default network parameters! *
*****
Are you sure? (y/n)
```

SmartScanNG² Default Network Settings

```
HTTP port    80
HTTPS port   8080
FTP port     21
TELNET port  23
```

External Ethernet Default Settings

```
Use static address  Yes
Static IP           192.168.9.191
Static mask         255.255.255.0
Default gateway     192.168.9.1
DNS Server          192.168.9.1
```

- 9 Ping.** The Ping option provides for testing the ability to communicate across an Ethernet network.

A successful Ping attempt will look like this:

```
Enter an IP to ping: 10.14.22.150

Pinging '10.14.22.150'... Success! (Response took 0 ticks.)
```

An unsuccessful Ping attempt will look like this:

```
Enter an IP to ping: 10.14.22.250

Pinging '10.14.22.250'... Failed!
```

- 10** The **Display IP Addresses** option shows the IP addresses available for direct access to the detector's Web Interface. Following each address is the HTTP port number configured/entered in the detector's Setup data. The number and type of addresses displayed depend on various firmware settings.

```
*****
* Web Addresses *
*****
DHCP: http://192.168.1.93:80
```

4.2.13 Talker Mode

To change the **Talker Mode**:

- 1 Be sure that the Setup menu is displayed.

The Setup Menu looks like this.

```
          :
          :
[M] - Talker Mode ..... Talk Freely
[N] - Velocity ..... COM 3
[O] - Wind Settings
[X] - Exit
```

The **Talker Mode option** lets you select when announcements are given during and after train passage. The **Talk Freely** mode is the normal talker mode. In this mode, the system makes announcements even when defects aren't detected. In **Talk on Defect** mode, the system makes announcements only when an alarm or Integrity Failure is detected. **Talk Reduced** mode is a combination of the Talk Freely and Talk On Defect modes. In this mode, trains entering a site always receive an Arrival announcement but only receive an EOT announcement if they contain an alarm or Integrity Failure. The default Talker Mode is Talk Freely.

- 2 Select the **Talker Mode** option, then select the desired setting of **Talk Freely**, **Talk on Defect**, or **Talk Reduced**.

```
Talker Mode
-----
[1] - Talk Freely
[2] - Talk on Defect
[3] - Talk Reduced
```

4.2.14 Velocity

The **Velocity** parameter is used to enable or disable the Velocity setting:

- 1 Be sure that the Setup menu is displayed.

The Setup Menu looks like this.

```
      .
      .
      .
[N] - Velocity ..... Enabled
[O] - Wind Settings
[X] - Exit
```

- 2 Select **Velocity** to change the option from Disabled to Enabled.

```
Select Velocity Mode:
[1] - Disabled
[2] - Enabled
```

4.2.15 Wind Settings

To change the **Wind Settings**:

- 1 Be sure that the Setup menu is displayed.

The Setup Menu looks like this.

```
      .
      .
      .
[O] - Wind Settings
[X] - Exit
```

- 2 Select **Wind Settings** to view menu options:

```
Wind Settings
-----
[A] - Wind Monitor ..... Not Installed
[B] - High Wind Alarm Limit ..... 50 mph
[C] - Display Wind Diagnostics ..... No
[D] - Wind Poll Interval ..... 15 sec
[E] - Slow Wind Speed Limit ..... 2 mph
[F] - Lower Interval Identical Limit ..... 360 min
[G] - Upper Interval Identical Limit ..... 30 min
[H] - Wind Gust Interval ..... 5 min
[I] - Suspicious Temp. Interval ..... 720 min
[J] - Re-enable Wind Updates ..... 10 min
[K] - Wind Alarm Reporting Interval ..... 5 min
[X] - Exit
```

- 3 Select **Wind Monitor** to toggle the setting between Installed (enabled) and Not Installed (disabled).

- 4 The **High Wind Alarm Limit** is a wind speed (in MPH) at or above which the detector flags a high wind alarm. Select High Wind Alarm Limit to change the setting:

```
High Wind Alarm Limit setting (default = 50 mph)
Enter a value from 30 to 80:
```

- 5 Select **Display Wind Diagnostics** to toggle the setting between Yes (enabled) and No (disabled). When enabling diagnostic output, the firmware prompts the user whether to disable output automatically. Pressing 'Y' or 'y' starts a thirty-minute timer and displays a corresponding message. (Note that the diagnostics do not begin until the user types "setup" to save the Setup change.) Pressing 'N' or 'n' at the prompt enables the diagnostics indefinitely and produces a "Wind diagnostics enabled indefinitely" message. Pressing ESC is the same as pressing 'N.' When limiting the diagnostics to thirty minutes, a "Wind Diagnostics Automatically Disabled!" message posts to the screen and into the Event Log when their output ceases.

```
Automatically disable diagnostics after 30 minutes? (Y/N)
Wind diagnostics enabled for 30 minutes.
```

- 6 Select **Wind Poll Interval** to modify the time interval (in seconds) at which the detector polls the wind monitor for new wind data.

```
Wind Poll Interval setting (default = 15 sec)
Enter a value from 1 to 30:
```

The detector contains logic for flagging errors if a wind monitor reports identical wind speed or wind direction readings for a specified interval. This logic uses the three parameters below. The **Slow Wind Speed Limit** parameter defines (in MPH) a wind speed considered slow for the site in question. For wind speeds below the Slow Wind Speed Limit value, if the wind monitor reports a constant wind speed or wind direction value for the time interval defined by the **Lower Interval Identical Limit** (in minutes), the detector flags a corresponding error (speed or direction). For wind speeds equal to or above the Slow Wind Speed Limit value, if the wind monitor reports a constant wind speed or wind direction value for the time interval defined by the **Upper Interval Identical Limit** (in minutes), the detector flags a corresponding error (speed or direction).

- 7 Select **Slow Wind Speed Limit** to modify the setting (in miles per hour).

```
Slow Wind Speed Limit setting (default = 2 mph)
Enter a value from 0 to 5:
```

- 8 Select **Lower Interval Identical Limit** to modify the setting (in minutes).

```
Lower Interval Identical Limit setting (default = 360 min)
Enter a value from 10 to 600:
```

- 9 Select **Upper Interval Identical Limit** to modify the setting (in minutes).

Upper Interval Identical Limit setting (default = 30 min)
Enter a value from 10 to 60:

- 10 A wind gust is a continuous record of the highest wind speed recorded during a defined time interval. The Wind Gust Interval parameter defines this time interval (in minutes). For example, if the Wind Gust Interval is five minutes, the wind gust value records the highest wind speed reported during the previous five minutes. Select **Wind Gust Interval** to modify the setting (in minutes).

Wind Gust Interval setting (default = 5 min)
Enter a value from 3 to 10:

- 11 Suspicious Temp. Interval: This parameter functions like the Lower Interval Identical Limit and Upper Interval Identical Limit parameters described above but for the temperature probe instead of the wind monitor. If the temperature probe reports a constant temperature value for the time interval defined by the Suspicious Temp. Interval parameter (in minutes), the detector flags a failure error for the probe. Select **Suspicious Temp. Interval** to modify the setting (in minutes).

Suspicious Temp. Interval setting (default = 720 min)
Enter a value from 10 to 720:

- 12 Re-enable Wind Updates: Time interval (in minutes) that must elapse after a train stops on the site before the detector again begins polling the wind monitor for data. When a train enters the site, the detector stops polling the wind monitor until either the train clears the site or it stops on the site, and this time interval elapses. Select **Re-enable Wind Updates** to modify the setting (in minutes).

Re-enable Wind Updates setting (default = 10 min)
Enter a value from 1 to 15:

- 13 Wind Alarm Reporting Interval: Time interval (in minutes) defining how often a detector repeats reporting an existing high wind alarm. Once a high wind alarm occurs, the detector repeats reporting the alarm's existence at this interval as long as the alarm condition exists. Select **Wind Alarm Reporting Interval** to modify the setting (in minutes).

Wind Alarm Reporting Interval setting (default = 5 min)
Enter a value from 2 to 15:

DEFAULT WIND SETTINGS

Parameter	Units	Min	Max	Default
High Wind Alarm Limit	MPH	30	80	50
Wind Poll Interval	seconds	1	30	15
Slow Wind Speed Limit	MPH	0	5	2
Lower Interval Identical Limit	minutes	10	600 (10 hours)	360 (6 hours)
Upper Interval Identical Limit	minutes	10	60 (1 hour)	30
Wind Gust Interval	minutes	3	10	5
Suspicious Temp. Interval	minutes	10	720 (12 hours)	720 (12 hours)
Re-enable Wind Updates	minutes	1	15	10
Wind Alarm Reporting Interval	minutes	2	15	5

4.3 System Functions Menu

To execute one or more system functions:

- 1 Be sure that the Main menu is displayed.

The Main menu looks like this.

```
      .  
      .  
      .  
[K] - Event log  
[L] - System Functions Menu  
[M] - Replay train  
[N] - Security Menu  
[X] - Exit
```

- 2 Select the **System Functions Menu**.

If the System Functions menu is password protected, this prompt appears.

```
You are not logged in with admin privileges  
Enter password:
```

You are given one chance to type the correct password. If you don't type the correct password, the system returns to the Main menu.

If the password is less than 32 characters long, press **[Enter]** after typing the last character. If the password is the full 32 characters in length, pressing **[Enter]** isn't necessary.

```
System Functions Menu
-----
[A] - Radio/Audio Menu
[B] - Start Manual Train
[C] - Auto-Calibration
[D] - Reboot System
[E] - Delete All Stored Train Data
[F] - Clear Event Log
[G] - Update Menu
[H] - Maintenance Menu
[I] - Resistor Baseline Data
[J] - Scanner Test
[K] - Calibrate Frauscher Transducers
[L] - Virtual Gate Test
[M] - AUX OUT Relay Menu
[X] - Exit
```

To access any of the System Functions menu options, type the letter that corresponds to the desired menu option. If a train is at the site when the System Functions menu is generated, ***** Train Is Present ***** is displayed just above the menu header for the System Functions menu.

- 3 To leave the System Functions menu and return to the Main menu:
 - a Type **X**. The Main menu reappears.
 - b Skip the remaining steps.
- 4 To execute one or more Radio or Audio functions, select the Radio/Audio Menu.

```
Radio/Audio Menu
-----
[A] - Radio Test
[B] - Vocabulary Test
[C] - Timed Radio Inhibit
[D] - 1KHz Test Tone
[E] - Volume Up (3)
[F] - Volume Down (3)
[G] - Radio Programming Menu
[X] - Exit
```

- 5 To execute the **radio test**:

The Radio Test option is used to broadcast a short message through the speaker and through the radio. Using this option lets you verify that the speaker and radio are working properly.

At single-track sites, the text of the message is "Testing, U P Detector, milepost, (*milepost number*), testing, one, two, three, four, five, four, three, two, one, testing." At double-track sites, the text of the message is "Testing, U P Detector, milepost, (*milepost number*), track (*track designation*), testing, one, two, three, four, five, four, three, two, one, testing."

```
Radio/Audio Menu
-----
[A] - Radio Test
[B] - Vocabulary Test
[C] - Timed Radio Inhibit
      .
      .
```

- a Select **Radio Test** from the Radio/Audio Menu.

If the system isn't currently making any other voice announcements, it begins the Radio Test announcement. After the announcement finishes, the System Functions menu reappears.

If the system is currently making a voice announcement, the firmware begins the Radio Test after all previously queued announcements finish.

- b While listening to the message, look at the PTT LED on the display panel.

The **PTT LED** should be lit.

If this LED isn't lit, the system's ability to send a message to the radio might be inhibited by the Radio Inhibit option on the System Functions menu. If the radio is inhibited, the results of this check are invalid.

- c Return to step 3.

6 To execute the **vocabulary test**:

The Vocabulary Test option is used to enunciate all stored speech phrases. This announcement is broadcast through the speaker but not through the radio. Therefore, it isn't affected by the enabled Radio Inhibit option.

The text of the message is "zero, one, two, three, four, five, six, seven, eight, nine, a, alarm, alarms, axle, axles, b, beginning, box, c, car, cars, critical, d, defect, defects, detector, dragging, e, east, equipment, excess, f, fifth, first, fourth, from, g, h, have, high, hot, i, ID, in, inspect, j, k, l, left, length, load, m, main, middle, milepost, minus, n, near, no, north, not, o, of, off, **beep**, out, p, point, power, q, r, rail, rebroadcast, remainder, resistor, right, s, scanner, second, a, side, sixth, slow, south, speed, system, t, temperature, test, testing, third, through, too, total, track, u, v, w, west, wheel, wide, working, x, y, you, z, repeat, excessive, train, minute, minutes, **1/4-second beep**, at, integrity_failure, an, hbd, Union Pacific."

```
Radio/Audio Menu
-----
[A] - Radio Test
[B] - Vocabulary Test
[C] - Timed Radio Inhibit
      .
      .
      .
```

a Select **Vocabulary Test** from the Radio/Audio Menu.

A prompt like this appears.

```
The Vocabulary Test may take several minutes to complete.

Are you sure? (y/n)

Vocabulary Test started. Press 'Esc' to cancel.
```

If the system isn't currently making any other voice announcements, it begins the Vocabulary Test announcement. After the announcement finishes, the System Functions menu reappears.

If the system is currently making a voice announcement, the firmware begins the Vocabulary Test after all previously queued announcements finish.

b Return to step 3.

7 To execute the **Timed radio inhibit**:

The Radio Inhibit option is used to prevent radio activation for three minutes. During this time, any announcements generated by the system are broadcast through the speaker but not through the radio. This feature may be overridden by recalling this submenu and then typing **N**.

```
Radio/Audio Menu
-----
[A] - Radio Test
[B] - Vocabulary Test
[C] - Timed Radio Inhibit
      .
      .
      .
```

a Select **Timed Radio Inhibit** from the Radio/Audio Menu.

This prompt appears.

```
PTT disabled for 3 minutes
```

- b** Select **Re-enable radio PTT** to disable Radio Inhibit.

```
Radio/Audio Menu
-----
[A] - Radio Test
[B] - Vocabulary Test
[C] - Re-enable Radio PTT
      .
      .
      .
```

- c** Return to step 3.

- 8** To generate the **1KHz test tone**:

The 1KHz Test Tone option is used to generate a continuous 1KHz tone for about 5 seconds. This test tone is broadcast through the speaker and through the radio.

```
Radio/Audio Menu
-----
[A] - Radio Test
[B] - Vocabulary Test
[C] - Re-enable Radio PTT
[D] - 1KHz Test Tone
      .
      .
      .
```

- a** Select **1KHz Test Tone** from the Radio/Audio Menu.

If the system isn't currently making any other voice announcements, it begins the tone.

If the system is currently making a voice announcement, the firmware begins the tone after all previously queued announcements finish.

- b** While listening to the tone, look at the PTT LEDs on the display panel.

The **PTT LED** should be lit.

If this LED isn't lit, the system's ability to send a tone to the radio might be inhibited by the Radio Inhibit option on the System Functions menu. If the radio is inhibited, the results of this check are invalid.

- c The amplitude of the audio signal routed to the radio is software-controlled and can be adjusted via new menu options in the serial interface. The “1 KHz Test Tone” option on the serial interface’s “Radio/Audio Menu” will present users with a menu if the SICM Board Rev is 2.00 or greater. This new menu provides the user with options for adjusting the Transmit Audio signal level. When the “1KHz Test Tone” option is selected, the 1KHz tone will play continuously until the menu is exited or no keypresses are detected for 1 minute, and the following menu appears.

```
Digital pot:  11 out of 100
-----
[A] - Up
[B] - Down
[C] - Set digital pot to ____
[D] - Reset digital pot to previous (0)
[E] - Save and exit
```

- d Select the appropriate menu option to adjust the audio signal to the desired level.
e Return to step 3.

9 To adjust speaker volume:

```
Radio/Audio Menu
-----
[A] - Radio Test
[B] - Vocabulary Test
[C] - Timed Radio Inhibit
[D] - 1KHz Test Tone
[E] - Volume Up (3)
[F] - Volume Down (3)
      .
      .
      .
```

There are 10 selectable volume levels (0-9). Level 0 is the minimum volume, and Level 9 is the maximum volume. The current volume setting is indicated in parentheses.

- a From the Radio/Audio Menu, select **Volume up** to increment the current volume level or **Volume down** to decrement level.
b Return to step 3.

10 To access Radio Programming Menu:

On the Systems Functions menu is the Radio Programming Menu. This menu includes submenus that allow you to select active radio channels, program the operating frequencies, adjust audio deviation levels, and select carrier detect levels.

Programming is available only for Ritron DTX radios. When using the model 2300-375 Dual-Track Interface, the Ritron DTX radio is programmable from the Track-1 SmartSCAN NG² Defect Detector.

```
      .
      .
      .
[E] - Volume Up (3)
[F] - Volume Down (3)
[G] - Radio Programming Menu
[X] - Exit
```

Select **Radio Programming Menu** from the Radio/Audio Menu.

For Ritron radios, a menu like this appears (the displayed values are the defaults).

```
Identifying radio type... ..
Reading radio data... ..

SmartSCAN NG2, MP/KP:0001.2, Track:Single
02/19/2025 13:41:27, 13.8V, 54°F
DTX-160                               Firmware version: 1.05
Radio Programming Menu                 Transmit  Receive
-----
[A] - Channel 1..... 160.320   160.320
[B] - Channel 2..... 160.410   160.410
[C] - Channel 3..... 160.515   160.515
[D] - Channel 4..... 160.470   160.470
[E] - Channel 5..... 160.785   160.785
[F] - Channel 6..... 160.830   160.830
[G] - Channel 7..... 160.875   160.875
[H] - Channel 8..... 161.550   161.550
[I] - Carrier Detect On/Off (-dBm) ..... 110.0 / 115.0
[J] - Current channel ..... 1
[X] - Exit
```

Note: Radio menu cannot be accessed unless a Ritron DTX radio is plugged into the internal radio connector.

Radio Frequency Setup

The transmit and receive frequencies can be programmed for each of the eight available channels. Select the channel number to change its frequency designations. A prompt like this will appear.

```
          Transmit  Receive
          - - - - -  - - - - -
Channel 1 - 160.515  160.515

Enter new transmit frequency (###.###): 160.515
Enter new receive frequency (###.###): 160.515

Radio will not be programmed until you leave the menu and save
settings.
Enter new receive frequency (###.###):
```

Input format **###.###** where '#' may be 0-9. Include leading and trailing zeroes. These values must be between 160.215 and 161.565. Once you have made your changes, you must exit the radio menu and the equipment menu and save the settings. The radio will then begin programming the new frequencies. If you attempt to enter the Radio Frequency Menu when the radio is not plugged in or is not responding, you will receive the message "Radio channels not available, radio not responding." You can also check to see if the Radio is not responding by looking at the System Status Report under System Warnings. After booting up, the system takes about a minute to recognize the radio.

Carrier Detect On/Off Level

The CD (Carrier Detect) LED is an indication that the system is experiencing radio traffic. It operates similarly to squelch. If the CD LED is lit when there is no activity on the frequency, then it is recommended that the sensitivity be reduced by changing the Carrier Detect On and Off levels. The factory default settings are 110 -dBm for carrier detect on and 105 -dBm for carrier detect off. These settings rarely need to be adjusted and should be done so only by a qualified radio technician. For proper operation, the carrier detect on value should always be higher than the carrier detect off value. The difference between the two values represents the squelch hysteresis and is used to prevent squelch chatter when the received signal is near the squelch setting values. Typical hysteresis should be 5 dB.

Select **Carrier Detect ON/OFF**, and a prompt like this will appear.

```
The default value for Carrier Detect On is 110.0 (-dBm)
Enter new Carrier Detect On (-dBm) value between 060.0 and 127.0
(###.#):
```

Select **Current Channel** to activate the desired channel, and a prompt like this will appear.

```
Select a channel:
[A] - Channel 1
[B] - Channel 2
[C] - Channel 3
[D] - Channel 4
[E] - Channel 5
[F] - Channel 6
[G] - Channel 7
[H] - Channel 8
[I] - Hardware control
```

11 To initiate the Start Manual Train function:

In Manual Train Mode, the system opens all the shutters and simulates transducer pulses. During this time, a person can check various aspects of the installed components. The train is marked as a test train. There won't be any voltage (simulated heat) applied to the scanner inputs.

This test gates 256 simulated axles. You can stop this test by selecting the Stop Manual Train option.

The data generated for this test train is stored in the Trains directory.

```
System Functions Menu
-----
[A] - Radio/Audio Menu
[B] - Start Manual Train
[C] - Auto-Calibration
[D] - Reboot System
[E] - Delete All Stored Train Data
      .
      .
```

a Select Start Manual Train from the System Functions menu.

This prompt appears.

```
Speed? (default = 30 mph, max = 100 mph)
Axles? (default = 166, max = 5000)
Time limit? (default = 300 seconds, max = 1000 seconds)
Direction N or E? (y/n)
Broadcast test train? (y/n)

Ready to run train: 166 axles, 30 mph, 300-sec limit, N/E dir,
broadcast enabled.
Are you sure? (y/n)
```

Type Y to Start Manual Train. A prompt like this will appear.

```
Train Arrival
```

During the test train, the TO1 & TO2 LEDs on the Display Panel will flash with each simulated axle. When the test train finishes, the following prompt appears.

Train Departure

- b** Return to System Functions Menu.

12 To start **Auto-Calibration**:

The SmartScanNG² system self-calibrates its pyrometer interface circuitry. You need only put a preheated calibrated heat source on a scanner and place the system in autocalibration mode by using the Auto-Calibration option. The system then scans all pyrometer inputs until the signal from the calibrated heat source is located. The necessary adjustments to the related interface circuitry are automatically made while the system monitors its own progress by analyzing changes in the heat signals. Once the procedure has been completed, autocalibration mode is disengaged, and the calibration results are displayed on your computer. For more details, see **Appendix E & F - Calibration of Type II/Type III Scanners**.

- a** Place a preheated calibrated heat source on the scanner to be calibrated.
- b** Select Auto-Calibration from the System Functions menu.

The SmartScanNG² system will now calibrate the channel associated with the scanner on which the heat source has been placed. Follow along on your interface screen until you see "Auto-Calibration Disengaged." This message is an indication that the system is done with the calibration procedure. To abort the process, press [Esc] (on your computer) or remove the heat source (from the scanner).

- c** When "Auto-Calibration Disengaged" is displayed on your computer, remove the calibrated heat source.

Upon completion of autocalibration, the system acquires the scanner resistor temperature baseline values. The process begins with a 20-minute wait period in which the resistors are allowed to cool down. The system counts down during this period, sounding a tone each minute. After the 20-minute cooldown period, the system opens and closes the shutters for a period of 8 minutes.

- d** Return to System Functions Menu.

Calibration requests are dependent on the current battery voltage and are handled as follows:

- **Battery Okay:** Calibration proceeds normally.
- **Battery Low:** A message displays the current battery voltage and prompts the user whether to continue. These new displays appear below. If the user chooses to continue, the firmware records a "Scanner calibration requested during Low Battery (nn.nV) condition" Event Log entry where the current battery voltage appears in place of "nn.n." Calibrating during a Low Battery condition will further drain battery power, shortening the time the detector remains operating. Additionally, the resistor baseline values used during the post-train resistor integrity test correspond to the battery voltage used during acquisition of the baseline values. Gathering baseline values (which begins following calibration) during a Low Battery condition yields values that will not correspond to the values needed when the battery voltage returns to its normal operating level.

OLED Keypad

```
Battery Low (12.3V)
Calibration Is Not
Advised
Press Select to Cont
```

Web Interface

```
Battery Low (12.3V). Calibration is not advised. Continue with
calibration?
OK Cancel
```

- **Battery Dead:** A message displays the current battery voltage, and the firmware prohibits calibration. These new displays appear below. The firmware will not open the scanner shutters once the battery voltage drops below the Dead Battery threshold. It does this to conserve battery power and keep the detector running as long as possible. While running, the detector continues recording axles, scanning for auxiliary alarms, making voice announcements, and (if equipped) communicating with a central office.

```
Battery voltage (11.2V) is below the Dead Battery threshold (11.8V).
- or for 24V systems -
Battery voltage (16.8V) is below the Dead Battery threshold (18.0V).
!!! Calibration Prohibited !!!
```

OLED Keypad

```
Battery Dead (11.3V)
!!! Calibration !!!
!!! Prohibited !!!
Press Func to Exit
```

Web Interface

```
Battery Dead (11.3V). !!! Calibration Prohibited !!!
OK Cancel
```

- When calibrating, the system firmware displays reminders regarding using the red and black filter frames with Type III wheel scanners. A reminder to use a black filter frame when calibrating a Type III wheel scanner appears before calibration begins. A reminder to replace the red filter frame for a Type III wheel scanner follows calibration. Examples of these new displays appear below.

Serial Interface:

```

Scanner type:
-----
Rail 1:   Type III   Wheel 1:   Type III
Rail 2:   Type III   Wheel 2:   Type III
Is this correct? (y/n)

***INSTALL BLACK FILTER BEFORE CALIBRATING TYPE III WHEEL SCANNER***

This will start the calibration process.
Are you sure? (y/n)
.
.
.
North Bearing Scanner Calibration complete.

Done

***INSTALL RED FILTER AFTER CALIBRATING TYPE III WHEEL SCANNER***

```

Web Interface:

Before Calibration

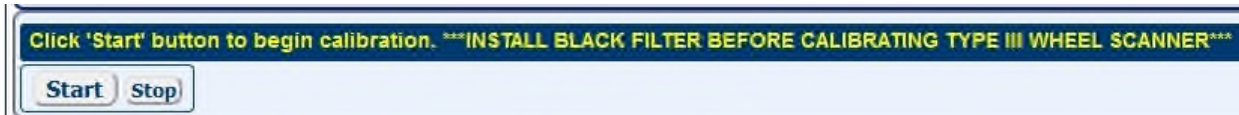

After Calibration

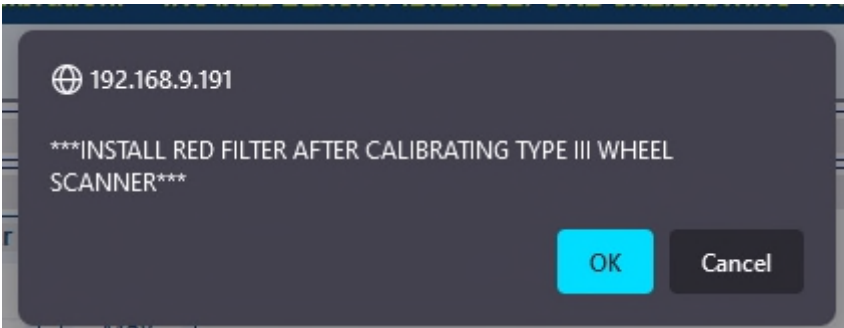

OLED Keypad:

Before Calibration

```
INSTALL BLACK FILTER
BEFORE CALIBRATING
TYPE III WHEEL SCNR
Press Select to Cont
```

After Calibration

```
INSTALL RED FILTER
AFTER CALIBRATING
TYPE III WHEEL SCNR
Press Select to Cont
```

13 To force a **system reboot**:

The System Reboot option allows you to force a system reset.

- a Select Reboot System from the System Functions menu.

This prompt appears.

```
Reboot System
Are you sure? (y/n)
```

- b To not reset the system:

- Type **N**.

The System Functions menu reappears.

- c To reset the system, type **Y**.

A screen similar to this appears.

```
Restarting in 2 seconds
Waiting 2sec to start 'A' to abort
Configured IP = 0.0.0.0
Configured Mask = 0.0.0.0
MAC Address= 00:03:f4:08:8c:fe
.
.
Comm is booting...
Starting telnet task on port 23... running.
.
.
Press 'Esc' for main menu.
```

After a few seconds, the screen displays "Press 'Esc' for the main menu."

14 To Delete All Stored Train Data:

The Delete All Stored Train Data option allows you to erase all stored train data. This encompasses all data in the Trains and Exceptions directories. After deleting all the train data, there isn't any way of regenerating it. The data is gone forever.

```
      .
      .
      .
[D] - Reboot System
[E] - Delete All Stored Train Data
[F] - Clear Event Log
[G] - Update Menu
      .
      .
      .
```

- a Select Delete All Stored Train Data from the System Functions menu.

This prompt appears.

```
Are you sure? (y/n)
```

- b To not delete all stored train data:

- Type **N**.

The System Functions menu reappears.

- c To delete all stored train data, type **Y**.

This message appears.

```
Train data cleared.
```

15 To Clear Event Log:

The Clear Event Log option is used to erase all events stored in the Event Log and display them on the Event Log report. After deleting the log, there isn't any way of regenerating it. The data is gone forever.

```
      .
      .
      .
[D] - Reboot System
[E] - Delete All Stored Train Data
[F] - Clear Event Log
[G] - Update Menu
      .
      .
      .
```

- a Select Clear Event Log from the System Functions menu.

This prompt appears.

```
Are you sure? (y/n)
```

- b** To not delete all events stored in the Event Log:
 - Type **N**.

The System Functions menu reappears.

- c** To delete all events stored in the Event Log, type **Y**.

This message appears.

```
Event log erased.
```

The System Functions menu reappears.

16 To access the **Update Menu**:

The Update Menu allows the user to update their firmware.

```
      .
      .
      .
[D] - Reboot System
[E] - Delete All Stored Train Data
[F] - Clear Event Log
[G] - Update Menu
      .
      .
      .
```

- a** Select Update Menu from the System Functions menu.

This prompt appears.

```
Update Menu
-----
[A] - Select Update File
[X] - Exit
```

- b** Choose Select Update File from the Update menu.

A menu similar to this appears.

```
Select update file:
[A] - UP_00-69.ng
[B] - UP_00-70.ng
```

The contents of the above list will be dependent upon the software update files that have been uploaded to the system (via the web page interface).

- c** Select the appropriate file from the menu options.

This prompt appears.

```
Are you sure you want to start the update process? (y/n)
```

If you type **N**, you will get an “Update aborted” message.

If you type **Y**, the update process will be initiated. A prompt similar to this will appear as the pending update is extracted, verified, and applied.

```
Update Menu
-----
[A] - Select Update File
[X] - Exit

Select update file:
[A] - UP_06-10.ng
Are you sure you want to start the update process?
This will erase all stored train data and clear the Event Log. Continue? (y/n)
Extracting update files
Extracting... Read 3929101 of 3929101 bytes (100%)
Extraction complete!
File extracted
Sending update files to Analyzer
Successfully sent files to Analyzer
Update is now pending and must be verified before it's applied.

SmartSCAN NG2, MP/KP:0001.2, Track:Single
02/26/2025 16:28:49, 24.2V, 42°F
Update Menu
-----
[A] - Select Update File
[B] - Verify Pending Update - UP_06-12x 2025-01-21 16:28:48
[X] - Exit

Verifying...
Comm successfully verified
Analyzer verification success
Verification complete. Result: success

SmartSCAN NG2, MP/KP:0001.2, Track:Single
02/26/2025 16:29:40, 24.2V, 42°F
Update Menu
-----
[A] - Select Update File
[C] - Apply Pending Update - UP_06-12x 2025-01-21 16:28:48
[X] - Exit

Applying the update will cause the system to reboot once complete.
Are you sure? (y/n)
Applying pending update
Running verified update
Disabling watchdog
Update: Same version
Update: Ok

SmartSCAN NG2, MP/KP:0001.2, Track:Single
02/06/2025 09:55:55, 24.4V, 54°F
Update Menu
-----
[A] - Select Update File

Running... success
Moving application files into place[C] - Apply pending update - /FLASH/UPDATES/UP_00-
17.ng 02/06/2025 09:54:23
[X] - Exit
System Update successful
Restarting in 2 seconds
Waiting 2sec to start 'A' to abort
```

17 To view Maintenance Menu:

The Maintenance Menu allows you to view statistics, reset system health, and edit the maintenance email list to which the detector reports maintenance issues.

```
      .  
      .  
      .  
[H] - Maintenance Menu  
[I] - Resistor Baseline Data  
[J] - Scanner Test  
[K] - Calibrate Frauscher Transducers  
[L] - Virtual Gate Test  
[M] - AUX OUT Relay Menu  
[X] - Exit
```

Select the Maintenance Menu from the System Functions menu.

A prompt like this appears.

```
Maintenance Menu  
-----  
[A] - View Maintenance Statistics  
[B] - Reset System Health  
[C] - Re-evaluate Last 40 Trains.  
[D] - Maintenance Email List  
[X] - Exit
```

18 To view the Maintenance Statistics:

Select the View Maintenance Statistics option from the maintenance menu.

Information like this is displayed.

```

-----
STATISTICS                               Trains Evaluated: 40   Days Spanned: 3
-----
Scanner      Max Avg  Resistor Avg  Cold  Cold
              Max Avg  Max Avg  CF  Scanner Resistor
              Max Avg  Max Avg  cnt %  cnt %
-----
East Brng    74  24  300  300  0  0  0  0  0  Avg  27.8  +75
West Brng    67  24  300  295  0  0  0  0  0  Max  28.0  +88
                                           Min  27.8  +66
-----

.....
Transducer Data
-----
Total Axles Scanned..... 11988
Total Txd. Miscounts..... 0
Percent Miscounts..... 0.00%
Trains With Miscounts..... 0
Trains In Sample..... 40
Percent Trains W/ Miscounts.. 0.00%
-----

Hardware Status
.....
East Bearing Scanner.....Pass
West Bearing Scanner.....Pass
East Wheel Scanner.....Disabled
West Wheel Scanner.....Disabled
Gating Transducers.....Pass
Ambient Temperature Probe.....Pass
Power.....Pass
Presence Hardware.....Disabled
Dragger.....Pass
High Load Detector.....Disabled
Wide Load Detector.....Disabled
AEI Subsystem.....Pass

```

19 To Reset System Health:

Reset System Health clears all of the maintenance statistics currently stored.

```

Maintenance Menu
-----
[A] - View maintenance statistics
[B] - Reset System Health
[C] - Maintenance email list
[X] - Exit

```

a Select Reset System Health from the Maintenance menu.

A prompt like this appears.

```

Are you sure? (y/n)

```

b To not reset system health:

- Type **N**.

The Maintenance Menu reappears.

c To reset system health, type **Y**. This prompt appears.

```
System health cleared
```

The Maintenance Menu reappears.

20 To access **Maintenance email list**:

The Maintenance email list is a contact list of those who receive email updates which are sent out whenever status changes occur in the Maintenance Statistics.

```
Maintenance Menu
-----
[A] - View maintenance statistics
[B] - Reset System Health
[C] - Maintenance email list
[X] - Exit
```

a Select Maintenance email list from the Maintenance menu.

A prompt like this appears.

```
Maintenance email list
-----
[A] - john.smith@southern-tech.com
[P] - New email address
[Q] - Email subject: Cromwell NG2
[X] - Exit
```

b Select New email address to add a new address or select an existing address to edit or delete from the list.

c Select the Email Subject option to specify the contents of the Subject line that will be applied to any maintenance-related emails sent by the SmartScanNG².

d Type X to return to the System Functions menu.

Sample Maintenance email:

From: no-reply@southern-tech.com [mailto:no-reply@southern-tech.com]

Sent: Sunday, February 11, 2025 6:46 PM

To: customer@UP.com

Subject: Maintenance email from UPHBD Track 2 Milepost: 1234.5, IP: 192.168.1.201

This is an automated maintenance email from an NG2 detector. Do not reply to this email. To unsubscribe from the Maintenance Alert email list, you will need to log in to the detector. On the web interface, this can be done from the System Functions Tab. In the serial or telnet interface this can be done by going to "System Functions Menu -> Maintenance Menu -> Maintenance email list".

The following items are what generated this report:

Gating Transducers: Previous status - Needs Attention | Current status - Pass

STATISTICS

Trains Evaluated: 40 Days Spanned: 2

Scanner	Max	Avg	Resistor		Avg CF	Cold Scanner		Cold Resistor		Batt	Amb Temp
			Max	Avg		cnt	%	cnt	%		
East Brng	55	9	292	241	0	2	5	0	0	Avg 14.0	+54
West Brng	52	6	300	279	0	3	7	0	0	Max 14.1	+63
East Whl	110	0	329	290	0	0	0	0	0	Min 13.9	+47
West Whl	91	0	335	260	1	0	0	0	0		

.....
Transducer Data

Total Axles Scanned..... 12894
Total Txd. Miscounts..... 0
Percent Miscounts..... 0.00%
Trains With Miscounts..... 0
Trains In Sample..... 40
Percent Trains W/ Miscounts.. 0.00%

Hardware Status

.....
East Bearing Scanner.....Pass
West Bearing Scanner.....Pass
East Wheel Scanner.....Pass
West Wheel Scanner.....Pass
Gating Transducers.....Pass
Ambient Temperature Probe.....Pass
Power.....Pass
Presence Hardware.....Disabled
Dragger.....Disabled
High Load Detector.....Disabled
Wide Load Detector.....Disabled
AEI Subsystem.....Pass

21 To view Resistor Baseline Data:

```

      .
      .
      .
[I] - Resistor Baseline Data
[J] - Scanner Test
[K] - Calibrate Frauscher Transducers
[L] - Virtual Gate Test
[M] - AUX OUT Relay Menu
[X] - Exit

```

- a** Select Resistor Baseline Data from the System Functions menu.

Data like this appears.

Resistor Data																																				
VOLTS	AMB	DATE	TIME	STATUS	30	40	50	60	70	80	90	100	110	120	130	Offset																				

	140	160	180	200	220	240	260	280	300	320	340	360	380	400	420	440	460	480																		

Rail 1 (Type III)																																				
24.5	36	03/13/23	14:56	VALID	208	238	262	277	282	282	282	282	282	282	282	282	282	282	18																	
	282	282	282	282	282	282	282	282	282	282	282	282	282	282	282	282	282	282																		
Rail 2 (Type III)																																				
24.5	36	03/13/23	14:56	VALID	200	233	262	277	281	281	281	281	281	281	281	281	281	281	19																	
	281	281	281	281	281	281	281	281	281	281	281	281	281	281	281	281	281	281																		
Wheel 1 (Type III)																																				
24.5	36	03/13/23	14:56	VALID	220	242	270	277	276	286	293	296	305	309	306	315	320	326	329	338	340	340	343	348	300	300	300	300	300	300	300	300	300	300	20	
	315	320	326	329	338	340	340	343	348	300	300	300	300	300	300	300	300	300	300	300	300	300	300	300	300	300	300	300	300	300	300	300	300	300		
Wheel 2 (Type III)																																				
24.5	36	03/13/23	14:56	VALID	200	231	267	281	288	292	306	308	326	326	328	330	336	342	354	354	361	365	368	366	300	300	300	300	300	300	300	300	300	300	300	24
	330	336	342	354	354	361	365	368	366	300	300	300	300	300	300	300	300	300	300	300	300	300	300	300	300	300	300	300	300	300	300	300	300	300		

For the resistor integrity test that is performed after train passage, there are two methods used to calculate the expected resistor temperature. The baseline resistor integrity test method requires the prerequisite of valid resistor baseline data to be stored in nonvolatile memory. Until the system acquires this data, it applies the interim resistor integrity test method to each train. The resistor data used in the baseline resistor integrity test method appears at the bottom of the System Status report. Included in the data above is a resistor heat profile of each scanner resistor, which covers a period of 30 to 480 seconds, in 10 and 20-second intervals. The differences in resistor heat between the two scanners are due to the cable lengths used in this example. Additional items in the data are the battery voltage measured with the shutters open, the date and time of the data acquisition, and the status of the heat profile data.

In this example, the status of both sets of resistor data is "VALID," meaning they are being used in the baseline integrity test for each train. There are two other possibilities for status, pending and invalid. If the word "PENDING" appears in the status column, the system is waiting for the resistors to cool before acquiring resistor data or for the battery to charge to 12.5 volts (12V system) or 22.0 volts (24V system). "INVALID" indicates that the system has tried twice and could not acquire valid resistor data. In either case, the system applies the interim integrity test to passing trains, which doesn't require resistor baseline data.

The system acquires the resistor data 20 minutes after the user calibrates the scanners with the autocalibration function. The resistor data acquisition runs unattended. Twenty minutes is the cooling period required to allow the resistors to return to ambient temperature after autocalibration. If a train should interrupt the cooling period, the resistor data acquisition runs 20 minutes after the shutters close following the passage of the train.

During the resistor-cooling period, the system announces through the speaker the following. These announcements aren't broadcast over the radio.

A beep sounds once per minute until two minutes before the resistor test.

At two minutes until the test, "Scanner resistor test beginning in 2 minutes" is voiced.

At one minute until the test, "Scanner resistor test beginning in 1 minute" is voiced.

After the resistor cooling period:

As the test begins, "Testing" is voiced. During this time, the word PENDING appears in the status column of the Resistor Data section.

If the test was successful, "System working" is voiced. The word VALID appears in the status column of the Resistor Data section, signifying that the baseline test applies to each passing train.

If the test wasn't successful, "Scanner resistor test beginning in two-zero minutes" is voiced, meaning that the system will try once more after 20 minutes to acquire an accurate resistor heat profile. During this time, the word PENDING appears in the status column of the Resistor Data section. If the test fails a second time, the word INVALID appears in the same column. The system applies the interim integrity test to each passing train while either PENDING or INVALID appears.

22 To initiate the **Scanner Test**:

```
      .  
      .  
      .  
[J] - Scanner Test  
[K] - Calibrate Frauscher Transducers  
[L] - Virtual Gate Test  
[M] - AUX OUT Relay Menu  
[X] - Exit
```

The scanner test function allows you to verify scanner accuracy. Place a calibrated heat source over a scanner's aperture and initiate the test. The detector will scan and display the temperature.

Select Scanner Test from the System Functions menu.

Test results like these appear.

```
East rail bearing scanner pot: 75
West rail bearing scanner pot: 72

The test will time out after 10 minutes
You can end the test early by pressing any key.

Beginning test...

East bearing   West bearing
      180           3
```

23 To perform a Calibrate Frauscher Transducers:

```
      .
      .
      .
[J] - Scanner Test
[K] - Calibrate Frauscher Transducers
[L] - Virtual Gate Test
[M] - AUX OUT Relay Menu
[X] - Exit
```

a Select Calibrate Frauscher Transducers from the System Functions menu.

A prompt like this appears.

```
Which transducer?
[A] - Transducer 1
[B] - Transducer 2
[C] - Both
```

Select a transducer (or both) to initiate calibration.

```
Are you sure? (y/n)

Sending calibration signal...
Calibration started, please wait up to 60 seconds...
Calibration complete
Transducer 1: Success
```

b Type any key to return to the System Functions menu.

24 To perform a Virtual gate test:

```
      .
      .
      .
[J] - Scanner Test
[K] - Calibrate Frauscher Transducers
[L] - Virtual Gate Test
[M] - AUX OUT Relay Menu
[X] - Exit
```

- a** Select **Virtual gate test** from the System Functions menu.

A prompt like this appears.

```
Select a scanner:  
[1] - East Rail  
[2] - West Rail  
[3] - East Wheel  
[4] - West Wheel
```

Select a scanner to initiate the test.

```
Are you sure? (y/n)  
You have 2 minutes to test.  
Test running, press any key to abort the test...
```

While in Virtual Gate Test Mode, the goal is to simulate a wheel that passes over the gating transducers and then continues moving to the scanner under test. The system notifies you when the simulated wheel is in the virtual gate area by cycling the shutters. The following steps describe how to use the Virtual Gate Test Mode.

- From the Virtual Gate Test Mode menu, select a scanner in which you want to see its Virtual Gate position.
- Swipe across the Gating Transducers with a metal object in the direction of the scanner under test. Maintain a speed faster than 1.6 seconds between sensors.
- Swipe across the sensors again. However, this time continue moving the metal object to the scanner under test while maintaining a constant speed.
- The shutters rapidly cycle one time to indicate when the system is looking for heat in the virtual window located at the scanner, which should be at the time that the metal object (simulated axle) passes the scanner. *If the shutters do not cycle, the entry for the closest transducer (TO1 or TO2) may be incorrect.*
- Simulating various axle speeds, repeat as needed to confirm settings.

The test mode runs for two minutes before timing out. Otherwise, any keypress ends the session. Rapid shutter flutter is an indication that two minutes have expired and the test has ended automatically. The event log records a canceled train at the end of the testing session.

- b** Type any key to return to the System Functions menu.

- 25** System firmware allows direct manipulation of an internal relay to control power to external devices. Detectors installed on the 2300-601 NG² chassis need no additional hardware. This chassis, which features the four scanner connectors in a single row, ships with a Double Pole Double Throw (DPDT) relay providing two sets of contacts, each with a Common, Normally Closed, and Normally Open terminal. When the firmware manipulates the relay, both sets of contacts change identically and simultaneously. Individual control of each set of contacts is not possible. The provided relay has a maximum current rating of 1A @ 30VDC and 0.50A @ 125VAC.

26 To change the status of the AUX OUT Relay:

```
      .
      .
[J] - Scanner Test
[K] - Calibrate Frauscher Transducers
[L] - Virtual Gate Test
[M] - AUX OUT Relay Menu
[X] - Exit
```

- a** Select **AUX OUT Relay Menu** from the System Functions menu.

A menu like this appears.

```
AUX OUT Relay Menu (Relay is De-Energized)
-----
[A] - Reset Relay
[B] - Energize Relay
[C] - De-Energize Relay (Normal State)
[X] - Exit
```

Select from available options. A prompt like this will appear.

```
Are you sure? (y/n)

Or

Energize relay for how many seconds (1-60)?
```

- **Reset Relay:** This option allows the user to cycle/reset the relay for a period of 1 to 60 seconds. Once selected, the firmware prompts for the number of seconds to energize the relay. Entry of an invalid number results in an "Invalid Entry!" display. Entering a valid number prompts the user for confirmation before executing the command. If a train is currently passing the site, the message "**** Train Is Present ****" precedes the confirmation prompt. When confirmed, the Reset Relay command energizes the relay for the number of seconds chosen and then returns the relay to its default de-energized state. If the Analyzer processor receives the relay command and sends the Comm processor a response, a "Command sent...Done!" message appears. If the Comm times out without receiving an Analyzer reply, a "Command sent...No response from Analyzer!" message appears.
- **Energize Relay:** This option switches the relay to its energized state. It will remain in this state until changed by one of the other menu options, or the detector is power-cycled or reset.
- **De-Energize Relay:** This option switches the relay to its de-energized (i.e., default/normal) state. It will remain in this state until changed by one of the other menu options.

The Energize Relay and De-Energize Relay options contain the train presence message, confirmation prompt, and "Command sent" message described in the Reset Relay entry. Each use of a relay command posts an entry in the Event Log containing the relay command requested, the time period given (relevant only for the Reset Relay command), whether a train was present, and whether the Comm received a reply from the Analyzer. Examples of the Event Log entries for the three commands follow:

- o "AUX OUT Relay Cmd: Reset Relay, 10 sec, Train=None, Reply=Ack"
- o "AUX OUT Relay Cmd: De-Energize Relay, 0 sec, Train=None, Reply=Ack"
- o "AUX OUT Relay Cmd: Energize Relay, 0 sec, Train=None, Reply=Ack"

If the user executes a relay command while a train crosses the site, the resulting Event Log entry shows "Train=Present" in place of "Train=None" in the above examples. If the Comm receives no Analyzer reply to a relay command, the resulting Event Log entry shows "Reply=Timeout" in place of "Reply=Ack" in the above examples.

4.4 Replay Train Announcements

The Replay Train option provides a means for playing the messages that were broadcast as a train passed a site, through the SmartScanNG²'s speaker, and/or for displaying the text for those messages in the user's terminal.

To replay the train announcement for a given train:

- 1 Be sure that the Main menu is displayed.

The Main menu looks like this.

```
Main Menu - Comm
-----
[A] - Train Summary
[B] - Train Detail
[C] - Exception Summary
[D] - Exception Detail
[E] - System Status Report
[F] - Last Train
[G] - Range of trains
[H] - Train DSRs
[I] - AEI Diagnostic
[J] - Setup
[K] - Event log
[L] - System Functions Menu
[M] - Replay train
[N] - Security Menu
[X] - Exit
```

2 Select Replay train.

These prompts appear.

```
Enter train number: 266
Exception train? (y/n)
Text only? (y/n)
```

- 3 Type the train number. If you typed fewer than four digits, press [Enter].
- 4 Indicate whether the train number you entered was retrieved from the Exception Summary Report or an Exception Detail Report. Type “Y” if it did.
- 5 If you want only to have the message text printed to your computer terminal (don’t also play the audio through the speaker) – Type “Y” in response to the prompt “Text only?”.

4.5 System Security

This menu is only available during the initial setup or when logged in with an administrative password.

To view or change system security settings:

Be sure that the Main menu is displayed.

The Main menu looks like this.

```
Main Menu - Comm
-----
[A] - Train Summary
[B] - Train Detail
[C] - Exception Summary
[D] - Exception Detail
[E] - System Status Report
[F] - Last Train
[G] - Range of trains
[H] - Train DSRs
[I] - AEI Diagnostic
[J] - Setup
[K] - Event log
[L] - System Functions Menu
[M] - Replay train
[N] - Security Menu
[X] - Exit
```

Select the Security Menu. If the Security menu is password-protected, this prompt appears.

```
You are not logged in with admin privileges
Enter password:
```

You are given one chance to type the correct password. If you don't type the correct password, the system returns to the Main menu. If the password is less than 32 characters long, press **[Enter]** after typing the last character. If the password is the full 32 characters in length, pressing **[Enter]** isn't necessary.

```
Security Menu
```

```
-----  
[A] - Admin password not set  
[B] - User password not set  
[X] - Exit
```

Select an option to set or change the password.

```
Enter a new password (20 character maximum):
```

5.0 Web User Interface

The web interface allows **on-site** and **off-site** communications with the system. This interface allows the user to view reports and modify system parameters.

For remote access via web browser:

- A computer with internet connectivity
- A SmartScanNG² with Ethernet connectivity

The SmartScanNG² web interface provides:

- Train Summary report
- Train Detail reports
- System Status report
- System configuration
- Event Log report
- Maintenance Information
- System Functions
- Software update
- Auto Calibration

To connect to the SmartScanNG² remotely with a web browser, the controller module must have Ethernet connectivity routed to the RJ45 connector, as shown below.

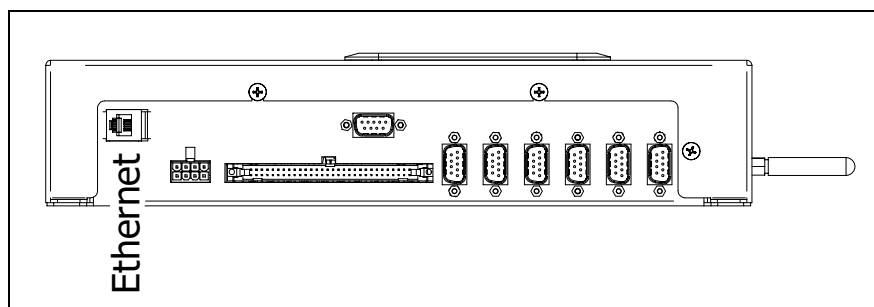

To view the web page for your SmartScanNG², open a web browser on your computer. Enter the unit's IP address into the address bar of your browser. Login with a username and password. See the example below. The contents of your web page will be similar.

The screenshot shows the SmartScanNG² web interface. At the top, it displays 'SMARTSCAN NG²' and system information: Milepost: 1234.5, Track: Single, 02/12/2025, 09:42, Battery: 14.2V, Temp: 46F. A green notification bar says 'A Train Is Present'. Below are navigation tabs: Train Data, System Status, Configuration, Logs, Maintenance Info, System Functions, Software Update, and Calibration. The 'Train Data' tab is active, showing a 'Train Summary Data' section with a dropdown menu and a 'Refresh' button. Below this is an 'Exception Train Summary' table with columns: Train, Date, Time, Cars, Axles, Lead ID, TO1, TO2, Dir, Speed (Min, Max, Exit), Bearing (Avg East, West), Wheel (Max East, West), AEI Tags, Temp, Bat, and Alarms. The table lists 21 train records with various details. At the bottom of the table are 'More' and 'All' buttons.

Click the “More” button at the bottom to load more train data.

The web page header includes the site's Milepost, Track Designator, Site ID, Date, Time, Battery voltage, Temperature, and Login status. The main page includes eight tabs. Train Data, System Status, Configuration, Logs, Maintenance Info, System Functions, Software Update, and Auto Cal. Clicking on the tabs will change the display in the main body of the page.

A pop-up indicator will appear above the tabs whenever a train is present.

On the Train Data tab between the Train Summary Data label and the header for the report columns is a key showing the various indicators present on the report (axle alarms, Integrity Failures, System Alarms, and DSR Records). Certain colors and characters at certain locations around a train's train number indicate the presence of these items. Hovering the mouse pointer over a train number also produces a pop-up window showing any axle alarms, Integrity Failures, and/or System Alarms present on the train.

5.1 Train Data

To view the train data, left-click the **Train Data** tab. The Train Summary Data will be displayed as depicted in the example above.

To view a train detail report, slide the mouse pointer to highlight the row for the desired train in the Train Summary Data Table. Left-click to select the train. A new window appears for each **Train Detail** report. This report also has the Show Announcements and Show DSR Charts buttons that display additional windows and information and provide replay and download of the spoken announcements. See the example below.

Train Details - Train #461
Milepost: 1234.5

Date: 02/12/25	Axles: 424	Speed	Train Length: 6829	Amb. temp.: +46F
Time: 04:21	T01: 424	Min: 31	Shutters Open: 134 sec	Battery: 14.2v
Dir: North	T02: 424	Max: 43		
	Cars: 105	Avg: 37		
		Exit: 31		

Software Version: NS_00-88x 2025-01-22

Scanner Performance					Alarm Limits		AEI System Data	
	Scanner	Max	Avg	Resistor Read Req	CF	Alarm	Limit	Tags Read
East Bearing	17	2	209	230	B 9	Critical	170	Antenna 0 0
West Bearing	27	1	155	222	B 30	Differential	115	Antenna 1 102
East Wheel	36	29	215	187	B 0	Hot Wheel	698	Length(AEI) 6847
West Wheel	21	10	236	223	B 0	Carside Slope	1.31	
Resistor Test Mode: Enabled						Carside Min	155	
						Cold Rail Temp	10	
						Announce Hot Wheels	Yes	
						Announce High Load	Yes	
						Announce Wide Load	Yes	
						Announce Differential	No	

System Alarms

AEI Subsystem: No Tags Ant 0
Cold West Resistor

Integrity Failures

None.

Axle Alarm Summary

None.

Show Announcements
Show DSR Charts

Car	Axle	Bearing		Wheel		ON	OFF	PW1	PW2	Alarms
		East	West	East	West					
NS 4407										
1	1	2	0	30	12	31	1733	21	21	
	2	2	0	32	21	31	72	21	21	
	3	2	0	29	12	31	72	21	20	
	4	3	0	29	15	31	491	21	21	
	5	5	0	32	18	31	72	21	21	
	6	3	0	34	12	31	72	21	20	
RKOX 6312										
2	7	2	0	26	8	31	146	18	18	
	8	2	6	32	12	31	61	18	18	
	9	2	0	29	12	31	731	18	18	
	10	2	3	30	12	31	61	19	19	

See Section **6.0 Producing Reports** for a detailed explanation of the various report headers.

Clicking the “Show DSR Charts” button causes a section to be added to the Train Detail report display, which presents graphical representations of any DSR records archived by the NG² for the train depicted in the report. A DSR record is the collection of heat samples gathered by the NG² for a given bearing or wheel. Ninety-six temperature samples are collected for each bearing and wheel. The “Bearing DSR Capture Temp.” and “Wheel DSR Capture Temp.” parameters establish the thresholds that determine which DSR records will be saved with the train data.

When the mouse pointer is moved over the DSR image, the values representing the DSR sample number and the temperature recorded for that image are presented for each point on the line. In the image below, 47 represents the DSR sample number, and 77 represents the temperature recorded for that sample.

The two gray vertical lines represent sample numbers 24 and 72. The area between these two lines represents the time during which the scanned bearing (or wheel) was between the two gating transducers.

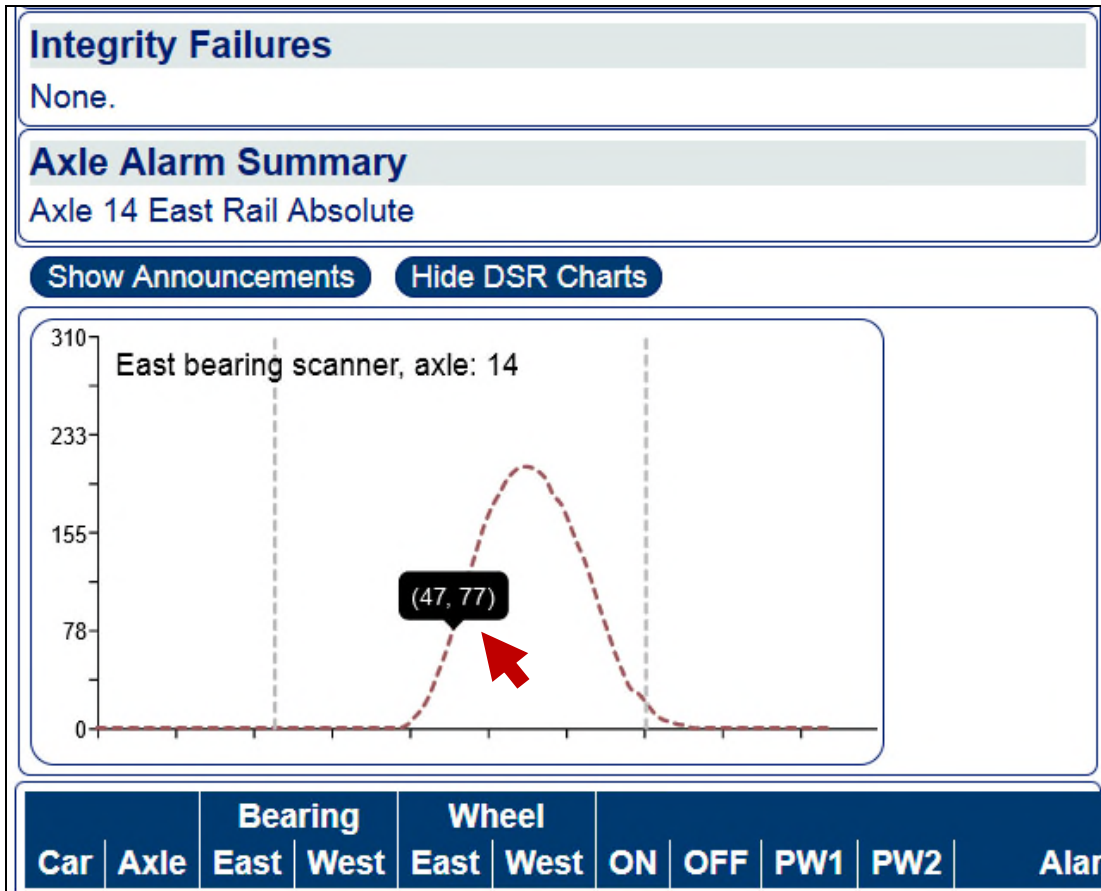

Display when “Show DSR Charts” is selected.

Clicking the “Show Announcements” button causes a section to be added to the Train Detail report display, which presents the voice messages that were broadcast by the detector while the train crossed the detector site. The section added to the report includes the broadcast messages in text form. It also provides for listening to these messages via your Web browser and for downloading a .wav file.

Integrity Failures

None.

Axle Alarm Summary

Axle 14 East Rail Absolute

Hide Announcements
Show DSR Charts

detector at kilometer post 7 2 1 5 point 3
 detector at kilometer post 7 2 1 5 point 3 you have a defect
 detector at kilometer post 7 2 1 5 point 3 hot box east rail axle 1 4 total axles 1 1 8 temperature 1 8
 detector at kilometer post 7 2 1 5 point 3 hot box east rail axle 1 4 total axles 1 1 8 temperature 1 8 detector out

Car	Axle	Bearing		Wheel		ON	OFF	PW1	PW2	Alarms
		East	West	East	West					

Display when “Show Announcements” is selected.

5.2 System Status

To view the system status, left-click the **System Status** tab. Grab and drag the slider bar to view the full range of system settings. See the example depicted below. By clicking on the header of a section of the display you can hide/show the contents of that section.

Slider Bar 

SMARTSCAN NG²

Milepost: 1234.5 Track: Single Site ID: NONAME 02/12/2025, 10:04Battery: 13.1V Temp: 87F

[Logged in as admin.](#) [Logout](#)

Train Data**System Status**ConfigurationLogsMaintenance InfoSystem FunctionsSoftware UpdateCalibration

System Status

Site Information ▲

Milepost	1234.5
Track Designator	Single
Site ID	NONAME
Track Direction	East/West
Time Zone	Central
Daylight Savings Time	Disabled
AC Power	On
AC Surge Suppressor	OK
Talker Mode	Talk Freely
SICM Board Rev	1.2 or lower
Software Version	UP_06-12x 2025-01-21
Speech Version	UP Linda 1.1
Velocity	Enabled
Active IP Settings	DHCP Addressing
IP Address	192.168.1.93
IP Mask	255.255.255.0
Default Gateway	192.168.1.1
DNS Server	192.168.1.1

Alarm Settings ▲

Absolute	170
Differential	117
Hot Wheel	900
Cold Journal Counter	3
Cold Journal Temp	10
Cold Res Counter	3
Differential Enabled	Yes

Alarm Settings (Advanced) ▲

Carside Slope	2.55
Carside Minimum	300
Res Test: Minimum Rail Avg	25
Res Test: Minimum Wheel Avg	28
Max Alarms	6

•
•
•

5.3 Configuration

To view the system configuration settings, left-click the **Configuration** tab. Then left-click the category tabs on the left to view or edit the various parameters. If necessary, grab and drag the slider bar on the right to view the full range of system settings. See the samples depicted below.

To modify the **Date/Time** setting, click on the parameter field and type the new value. The **Apply Changes** button will be outlined in red when changes have been entered. Left-click the **Apply Changes** button to save changes. A Changes Applied Successfully message will appear.

The screenshot displays the SMARTSCAN NG² web interface. At the top, the header shows the system name and status: Milepost: 1234.5, Track: Single, Site ID: NONAME, 02/12/2025, 10:08, Battery: 13.1V, Temp: 82F. A navigation bar includes tabs for Train Data, System Status, Configuration (selected), Logs, Maintenance Info, System Functions, Software Update, and Calibration. The Configuration section is active, showing a sidebar with various settings categories and a main panel for the selected 'Date/Time' category. The Date/Time panel includes fields for Date (02/12/2025), Time (10:08), Time Zone (Central), and Daylight Savings Time (Disabled), along with an 'Apply Changes' button.

Date/Time	
Date	02/12/2025
Time	10:08
Time Zone	Central
Daylight Savings Time	Disabled

Date/Time

To modify the **Site Parameters** settings, click on the parameter field and type the new value. The **Apply Changes** button will be outlined in red when changes have been entered. Left-click the **Apply Changes** button to save changes. A Changes Applied Successfully message will appear.

The screenshot displays the SMARTSCAN NG² web interface. At the top, the header shows the system name and status: Milepost: 1234.5, Track: Single, Site ID: NONAME, 02/12/2025, 10:09, Battery: 13.1V, Temp: 82F. A 'Logout' button is visible. Below the header is a navigation menu with buttons for Train Data, System Status, Configuration (highlighted), Logs, Maintenance Info, System Functions, Software Update, and Calibration. The main content area is titled 'Configuration' and includes a 'Load Default Setup Parameters' button. On the left is a vertical sidebar with menu items: Date/Time, Site Parameters (selected), Alarm Settings, Alarm Settings (Advanced), Equipment Settings, Equipment Settings (Advanced), Sunshot Settings, Frauscher Transducer Offsets, Message Settings, Message Settings (Advanced), Network Settings, Wind Settings, COM Port Settings, AEI Settings, and Import/Export. The 'Site Parameters' section is expanded, showing a table of settings: Milepost (1234.5), Site ID (NONAME), Track Designation (Single), Track Direction (E/W), Velocity (Enabled), and Talker Mode (Talk Freely). An 'Apply Changes' button is located below the table.

Site Parameters

To modify the **Alarm Settings**, click on the parameter field and type the new value. The **Apply Changes** button will be outlined in red when changes have been entered. Left-click the **Apply Changes** button to save changes. A Changes Applied Successfully message will appear.

The screenshot shows the SMARTSCAN NG² web interface. At the top, there is a header with the product name and a navigation bar with buttons for Train Data, System Status, Configuration, Logs, Maintenance Info, System Functions, Software Update, and Calibration. The Configuration page is active, showing a sidebar with various settings categories and a main content area for Alarm Settings. The Alarm Settings table includes parameters like Absolute, Differential, Hot Wheel, Cold Journal Counter, Cold Journal Temp, Cold Res Counter, and Differential Enabled, each with a value field and min/max constraints. An Apply Changes button is located below the table.

Alarm Settings		
Absolute	<input type="text" value="170"/>	min = 1, max = 300
Differential	<input type="text" value="117"/>	min = 1, max = 300
Hot Wheel	<input type="text" value="900"/>	min = 1, max = 900
Cold Journal Counter	<input type="text" value="3"/>	min = 1, max = 9
Cold Journal Temp	<input type="text" value="10"/>	min = 1, max = 30
Cold Res Counter	<input type="text" value="3"/>	min = 1, max = 9
Differential Enabled	<input type="text" value="yes"/>	

Alarm Settings

To modify the **Alarm Settings (Advanced)** settings, click on the parameter field and type the new value. The **Apply Changes** button will be outlined in red when changes have been entered. Left-click the **Apply Changes** button to save changes. A Changes Applied Successfully message will appear.

SMARTSCAN NG²

Milepost: 1234.5 Track: Single Site ID: NONAME 02/12/2025, 10:10 Battery: 13.1V Temp: 82F
 Logged in as admin. [Logout](#)

[Train Data](#) [System Status](#) [Configuration](#) [Logs](#) [Maintenance Info](#) [System Functions](#) [Software Update](#) [Calibration](#)

Configuration [Load Default Setup Parameters](#)

Alarm Settings (Advanced)

Carside Slope	<input type="text" value="2.55"/>	min = 0.01, max = 2.55
Carside Minimum	<input type="text" value="300"/>	min = 0, max = 300
Res Test: Minimum Rail Avg	<input type="text" value="25"/>	min = 0, max = 300
Res Test: Minimum Wheel Avg	<input type="text" value="28"/>	min = 0, max = 900
Max Alarms	<input type="text" value="6"/>	min = 1, max = 11

[Apply Changes](#)

Configuration Menu:
 Date/Time
 Site Parameters
 Alarm Settings
Alarm Settings (Advanced)
 Equipment Settings
 Equipment Settings (Advanced)
 Sunshot Settings
 Frauscher Transducer Offsets
 Message Settings
 Message Settings (Advanced)
 Network Settings
 Wind Settings
 COM Port Settings
 AEI Settings
 Import/Export

Alarm Settings (Advanced)

To modify the **Equipment Settings**, click on the parameter field and type the new value. The **Apply Changes** button will be outlined in red when changes have been entered. Left-click the **Apply Changes** button to save changes. A Changes Applied Successfully message will appear.

SMARTSCAN NG²

Milepost: 1234.5 Track: Single Site ID: NONAME 02/12/2025, 10:11
Battery: 13.1V Temp: 82F

[Logged in as admin.](#) [Logout](#)

Train Data
System Status
Configuration
Logs
Maintenance Info
System Functions
Software Update
Calibration

Configuration Load Default Setup Parameters

<div style="border: 1px solid #003366; padding: 2px; margin-bottom: 2px;">Date/Time</div> <div style="border: 1px solid #003366; padding: 2px; margin-bottom: 2px;">Site Parameters</div> <div style="border: 1px solid #003366; padding: 2px; margin-bottom: 2px;">Alarm Settings</div> <div style="border: 1px solid #003366; padding: 2px; margin-bottom: 2px;">Alarm Settings (Advanced)</div> <div style="background-color: #003366; color: white; text-align: center; padding: 2px; margin-bottom: 2px;">Equipment Settings</div> <div style="border: 1px solid #003366; padding: 2px; margin-bottom: 2px;">Equipment Settings (Advanced)</div> <div style="border: 1px solid #003366; padding: 2px; margin-bottom: 2px;">Sunshot Settings</div> <div style="border: 1px solid #003366; padding: 2px; margin-bottom: 2px;">Frauscher Transducer Offsets</div> <div style="border: 1px solid #003366; padding: 2px; margin-bottom: 2px;">Message Settings</div> <div style="border: 1px solid #003366; padding: 2px; margin-bottom: 2px;">Message Settings (Advanced)</div> <div style="border: 1px solid #003366; padding: 2px; margin-bottom: 2px;">Network Settings</div> <div style="border: 1px solid #003366; padding: 2px; margin-bottom: 2px;">Wind Settings</div> <div style="border: 1px solid #003366; padding: 2px; margin-bottom: 2px;">COM Port Settings</div> <div style="border: 1px solid #003366; padding: 2px; margin-bottom: 2px;">AEI Settings</div> <div style="border: 1px solid #003366; padding: 2px;">Import/Export</div>	<h4 style="margin: 0;">Equipment Settings</h4> <table style="width: 100%; border-collapse: collapse;"> <tr><td>Dragger</td><td style="text-align: right;">yes ▾</td></tr> <tr><td>Hot Wheel</td><td style="text-align: right;">yes ▾</td></tr> <tr><td>Hot Bearing</td><td style="text-align: right;">yes ▾</td></tr> <tr><td>High Load</td><td style="text-align: right;">no ▾</td></tr> <tr><td>Wide Load</td><td style="text-align: right;">no ▾</td></tr> <tr><td>AEI</td><td style="text-align: right;">no ▾</td></tr> <tr><td>North Rail Scanner Type</td><td style="text-align: right;">Type III ▾</td></tr> <tr><td>South Rail Scanner Type</td><td style="text-align: right;">Type III ▾</td></tr> <tr><td>North Wheel Scanner Type</td><td style="text-align: right;">Type III ▾</td></tr> <tr><td>South Wheel Scanner Type</td><td style="text-align: right;">Type III ▾</td></tr> <tr><td>Presence Hardware</td><td style="text-align: right;">yes ▾</td></tr> <tr><td>Advance Transducers</td><td style="text-align: right;">no ▾</td></tr> <tr><td>AC Power Off Monitor</td><td style="text-align: right;">yes ▾</td></tr> <tr><td>Cold Rail Test Mode</td><td style="text-align: right;">All trains ▾</td></tr> </table> <div style="text-align: center; margin-top: 10px;"> Apply Changes </div>	Dragger	yes ▾	Hot Wheel	yes ▾	Hot Bearing	yes ▾	High Load	no ▾	Wide Load	no ▾	AEI	no ▾	North Rail Scanner Type	Type III ▾	South Rail Scanner Type	Type III ▾	North Wheel Scanner Type	Type III ▾	South Wheel Scanner Type	Type III ▾	Presence Hardware	yes ▾	Advance Transducers	no ▾	AC Power Off Monitor	yes ▾	Cold Rail Test Mode	All trains ▾
Dragger	yes ▾																												
Hot Wheel	yes ▾																												
Hot Bearing	yes ▾																												
High Load	no ▾																												
Wide Load	no ▾																												
AEI	no ▾																												
North Rail Scanner Type	Type III ▾																												
South Rail Scanner Type	Type III ▾																												
North Wheel Scanner Type	Type III ▾																												
South Wheel Scanner Type	Type III ▾																												
Presence Hardware	yes ▾																												
Advance Transducers	no ▾																												
AC Power Off Monitor	yes ▾																												
Cold Rail Test Mode	All trains ▾																												

Equipment Settings

To modify the **Equipment Settings (Advanced)** settings, click on the parameter field and type the new value. The **Apply Changes** button will be outlined in red when changes have been entered. Left-click the **Apply Changes** button to save changes. A Changes Applied Successfully message will appear.

SMARTSCAN NG²

Milepost: 1234.5 Track: Single Site ID: NONAME 02/12/2025, 10:13 Battery: 13.1V Temp: 83F
 Logged in as admin. Logout

Train Data System Status Configuration Logs Maintenance Info System Functions Software Update Calibration

Configuration Load Default Setup Parameters

Equipment Settings (Advanced)

Date/Time	Equipment Settings (Advanced)	
Site Parameters	Clearance Mode	Multiplexed ▾
Alarm Settings	Clearance Type	Trip Wire ▾
Alarm Settings (Advanced)	Carside Slope	no ▾
Equipment Settings	Winter Cycle	yes ▾
Equipment Settings (Advanced)	Winter Cycle Start Month	January ▾
Sunshot Settings	Winter Cycle End Month	January ▾
Frauscher Transducer Offsets	Gate Distance (inches)	24.0 min = 18.0, max = 48.0
Message Settings	Dragger Debounce Time (mS)	100 min = 0, max = 999
Message Settings (Advanced)	Pre Train Dragger Dist (feet)	0 min = 0, max = 15
Network Settings	Pre Train High/Wide Dist (feet)	0 min = 0, max = 15
Wind Settings	Presence Timeout Period (seconds)	10 min = 5, max = 30
COM Port Settings	System Voltage	24 ▾
AEI Settings	Transducer Type	Frauscher ▾
Import/Export	Carrier Detect Active State	Low ▾
	Apply Changes	

Equipment Settings (Advanced)

To modify the **Sunshot Settings**, click on the parameter field and select or type the new value. The **Apply Changes** button will be outlined in red when changes have been entered. Left-click the **Apply Changes** button to save changes. A Changes Applied Successfully message will appear.

The screenshot shows the SMARTSCAN NG² web interface. At the top, there is a navigation bar with the logo and site information: Milepost: 1234.5, Track: Single, Site ID: NONAME, and a timestamp of 02/12/2025, 10:14. On the right, it displays Battery: 13.1V and Temp: 84F, along with a 'Logged in as admin. Logout' link. Below the navigation bar is a menu with buttons for Train Data, System Status, Configuration (which is highlighted), Logs, Maintenance Info, System Functions, Software Update, and Calibration. The main content area is titled 'Configuration' and includes a 'Load Default Setup Parameters' button. On the left is a sidebar menu with options: Date/Time, Site Parameters, Alarm Settings, Alarm Settings (Advanced), Equipment Settings, Equipment Settings (Advanced), Sunshot Settings (highlighted), Frauscher Transducer Offsets, Message Settings, Message Settings (Advanced), Network Settings, Wind Settings, COM Port Settings, AEI Settings, and Import/Export. The Sunshot Settings panel contains the following fields: Sunshot Filter (a dropdown menu set to 'Disabled'), Scanner Orientation (a text input field with '0' and a range of 'min = 0, max = 359'), Latitude (a text input field with '35.0456' and a range of 'min = 0.00, max = 90.00'), and Longitude (a text input field with '-85.3097' and a range of 'min = -180.00, max = 180.00'). An 'Apply Changes' button is located at the bottom of the Sunshot Settings panel.

Sunshot Settings

To modify the **Frauscher Transducer Offsets** settings, click on the parameter field and select or type the new value. The **Apply Changes** button will be outlined in red when changes have been entered. Left-click the **Apply Changes** button to save changes. A Changes Applied Successfully message will appear.

The screenshot shows the SMARTSCAN NG² web interface. At the top, there is a header with the logo and a navigation bar with buttons for Train Data, System Status, Configuration, Logs, Maintenance Info, System Functions, Software Update, and Calibration. Below the navigation bar, the Configuration page is active, showing a sidebar with various settings categories and a main content area for the Frauscher Transducer Offsets. The main content area includes a table of settings and an Apply Changes button.

Frauscher Transducer Offsets		
Rail Size (lbs/yd (kg/m))	136 (67.46) ▾	
Transducer Rail	Rail 1 ▾	
North Rail Scanner Offset	22	min = 0, max = 100
North Rail Nearest Txd	T01 ▾	
South Rail Scanner Offset	22	min = 0, max = 100
South Rail Nearest Txd	T01 ▾	
North Wheel Scanner Offset	0	min = 0, max = 100
North Wheel Nearest Txd	T01 ▾	
South Wheel Scanner Offset	0	min = 0, max = 100
South Wheel Nearest Txd	T01 ▾	

Apply Changes

Frauscher Transducer Offsets

To modify the **Messages** settings, click on the parameter field and type the new value. The **Apply Changes** button will be outlined in red when changes have been entered. Left-click the **Apply Changes** button to save changes. A Changes Applied Successfully message will appear.

The screenshot shows the SMARTSCAN NG² web interface. At the top, there is a navigation bar with the logo and a status bar displaying Milepost: 1234.5, Track: Single, Site ID: NONAME, and a timestamp of 02/12/2025, 10:17. The Battery level is 13.1V and the temperature is 87F. A 'Logout' button is visible in the top right. Below the navigation bar, there are several menu items: Train Data, System Status, Configuration (highlighted), Logs, Maintenance Info, System Functions, Software Update, and Calibration. The main content area is titled 'Configuration' and includes a 'Load Default Setup Parameters' button. On the left side of the configuration area, there is a vertical list of settings categories: Date/Time, Site Parameters, Alarm Settings, Alarm Settings (Advanced), Equipment Settings, Equipment Settings (Advanced), Sunshot Settings, Frauscher Transducer Offsets, Message Settings (highlighted), Message Settings (Advanced), Network Settings, Wind Settings, COM Port Settings, AEI Settings, and Import/Export. The 'Message Settings' section is expanded, showing a table of parameters with dropdown menus:

Message Settings	
Axles	yes ▾
Speed	yes ▾
Temperature	yes ▾
Length	no ▾
Slow	no ▾
Power Off	no ▾
Customer Name	yes ▾
Lft/Rt Alarm Ref	no ▾
Car ID With Alarm	no ▾

Below the table is an 'Apply Changes' button.

Messages Settings

To modify the **Messages Settings (Advanced)**, click on the parameter field and type the new value. The **Apply Changes** button will be outlined in red when changes have been entered. Left-click the **Apply Changes** button to save changes. A Changes Applied Successfully message will appear.

The screenshot shows the SMARTSCAN NG² web interface. At the top, there is a header with the logo and navigation tabs: Train Data, System Status, Configuration (selected), Logs, Maintenance Info, System Functions, Software Update, and Calibration. Below the header, system information is displayed: Milepost: 1234.5, Track: Single, Site ID: NONAME, Date/Time: 02/12/2025, 10:18, Battery: 13.1V, Temp: 86F, and a Logout button. The Configuration page is active, showing a sidebar with various settings categories and a main content area for 'Message Settings (Advanced)'. The sidebar categories include Date/Time, Site Parameters, Alarm Settings, Alarm Settings (Advanced), Equipment Settings, Equipment Settings (Advanced), Sunshot Settings, Frauscher Transducer Offsets, Message Settings, Message Settings (Advanced) (selected), Network Settings, Wind Settings, COM Port Settings, AEI Settings, and Import/Export. The main content area for 'Message Settings (Advanced)' contains a table of settings:

Message Settings (Advanced)		
Announce Hot Wheels	Yes	▼
Announce Differential	Yes	▼
Announce High Load	Yes	▼
Announce Wide Load	Yes	▼
Rebroadcast Time Limit (minutes)	10	min = 0, max = 240
Rebroadcast DTMF Code	001	
Num Repeat No Defects	1	min = 1, max = 3
EOT Repeat Delay (seconds)	1	min = 0, max = 240

Below the table is an 'Apply Changes' button.

Messages Settings (Advanced)

To modify the **Network Settings**, click on the parameter field and type the new value. The **Apply Changes** button will be outlined in red when changes have been entered. Left-click the **Apply Changes** button to save changes. A Changes Applied Successfully message will appear.

SMARTSCAN NG²

Milepost: 1234.5 Track: Single Site ID: NONAME 02/12/2025, 10:19
Battery: 13.1V Temp: 86F

[Logged in as admin.](#) [Logout](#)

Train Data
System Status
Configuration
Logs
Maintenance Info
System Functions
Software Update
Calibration

Configuration
[Load Default Setup Parameters](#)

<div style="border: 1px solid black; padding: 2px; margin-bottom: 2px;">Date/Time</div> <div style="border: 1px solid black; padding: 2px; margin-bottom: 2px;">Site Parameters</div> <div style="border: 1px solid black; padding: 2px; margin-bottom: 2px;">Alarm Settings</div> <div style="border: 1px solid black; padding: 2px; margin-bottom: 2px;">Alarm Settings (Advanced)</div> <div style="border: 1px solid black; padding: 2px; margin-bottom: 2px;">Equipment Settings</div> <div style="border: 1px solid black; padding: 2px; margin-bottom: 2px;">Equipment Settings (Advanced)</div> <div style="border: 1px solid black; padding: 2px; margin-bottom: 2px;">Sunshot Settings</div> <div style="border: 1px solid black; padding: 2px; margin-bottom: 2px;">Frauscher Transducer Offsets</div> <div style="border: 1px solid black; padding: 2px; margin-bottom: 2px;">Message Settings</div> <div style="border: 1px solid black; padding: 2px; margin-bottom: 2px;">Message Settings (Advanced)</div> <div style="border: 1px solid black; padding: 2px; margin-bottom: 2px; background-color: #003366; color: white;">Network Settings</div> <div style="border: 1px solid black; padding: 2px; margin-bottom: 2px;">Wind Settings</div> <div style="border: 1px solid black; padding: 2px; margin-bottom: 2px;">COM Port Settings</div> <div style="border: 1px solid black; padding: 2px; margin-bottom: 2px;">AEI Settings</div> <div style="border: 1px solid black; padding: 2px;">Import/Export</div>	<div style="border-bottom: 1px solid black; padding-bottom: 5px;">Network Settings</div> <table style="width: 100%; border-collapse: collapse;"> <tr> <td>Use Static Address</td> <td><input type="text" value="no"/></td> <td></td> </tr> <tr> <td>Static IP</td> <td><input type="text" value="192.168.1.99"/></td> <td></td> </tr> <tr> <td>Static Mask</td> <td><input type="text" value="255.255.255.0"/></td> <td></td> </tr> <tr> <td>Static Default Gateway</td> <td><input type="text" value="192.168.1.1"/></td> <td></td> </tr> <tr> <td>Static DNS Server</td> <td><input type="text" value="192.168.1.1"/></td> <td></td> </tr> <tr> <td>TELNET Port</td> <td><input type="text" value="23"/></td> <td>min = 0, max = 65535</td> </tr> <tr> <td>FTP Port</td> <td><input type="text" value="21"/></td> <td>min = 0, max = 65535</td> </tr> <tr> <td>HTTP Port</td> <td><input type="text" value="80"/></td> <td>min = 0, max = 65535</td> </tr> <tr> <td>HTTPS Port</td> <td><input type="text" value="8080"/></td> <td>min = 0, max = 65535</td> </tr> </table> <div style="text-align: center; margin-top: 10px;"> <input type="button" value="Apply Changes"/> </div>	Use Static Address	<input type="text" value="no"/>		Static IP	<input type="text" value="192.168.1.99"/>		Static Mask	<input type="text" value="255.255.255.0"/>		Static Default Gateway	<input type="text" value="192.168.1.1"/>		Static DNS Server	<input type="text" value="192.168.1.1"/>		TELNET Port	<input type="text" value="23"/>	min = 0, max = 65535	FTP Port	<input type="text" value="21"/>	min = 0, max = 65535	HTTP Port	<input type="text" value="80"/>	min = 0, max = 65535	HTTPS Port	<input type="text" value="8080"/>	min = 0, max = 65535
Use Static Address	<input type="text" value="no"/>																											
Static IP	<input type="text" value="192.168.1.99"/>																											
Static Mask	<input type="text" value="255.255.255.0"/>																											
Static Default Gateway	<input type="text" value="192.168.1.1"/>																											
Static DNS Server	<input type="text" value="192.168.1.1"/>																											
TELNET Port	<input type="text" value="23"/>	min = 0, max = 65535																										
FTP Port	<input type="text" value="21"/>	min = 0, max = 65535																										
HTTP Port	<input type="text" value="80"/>	min = 0, max = 65535																										
HTTPS Port	<input type="text" value="8080"/>	min = 0, max = 65535																										

Network Settings

To modify the **Wind Settings**, click on the parameter field and type the new value. The **Apply Changes** button will be outlined in red when changes have been entered. Left-click the **Apply Changes** button to save changes. A Changes Applied Successfully message will appear.

SMARTSCAN NG²

Milepost: 1234.5 Track: Single Site ID: NONAME 02/12/2025, 10:19
Battery: 13.1V Temp: 86F

[Logged in as admin.](#) [Logout](#)

Train Data
System Status
Configuration
Logs
Maintenance Info
System Functions
Software Update
Calibration

Configuration
[Load Default Setup Parameters](#)

Date/Time		
Site Parameters		
Alarm Settings		
Alarm Settings (Advanced)		
Equipment Settings		
Equipment Settings (Advanced)		
Sunshot Settings		
Frauscher Transducer Offsets		
Message Settings		
Message Settings (Advanced)		
Network Settings		
Wind Settings		
COM Port Settings		
AEI Settings		
Import/Export		

Wind Settings		
Wind Monitor	<input type="text" value="no"/>	
High Wind Alarm Limit (mph)	<input type="text" value="50"/>	min = 30, max = 80
Display Wind Diagnostics	<input type="text" value="no"/>	
Wind Poll Interval (seconds)	<input type="text" value="15"/>	min = 1, max = 30
Slow Wind Speed Limit (mph)	<input type="text" value="2"/>	min = 0, max = 5
Lower Interval Identical Limit (minutes)	<input type="text" value="360"/>	min = 10, max = 600
Upper Interval Identical Limit (minutes)	<input type="text" value="30"/>	min = 10, max = 60
Wind Gust Interval (minutes)	<input type="text" value="5"/>	min = 3, max = 10
Suspicious Temp. Interval (minutes)	<input type="text" value="720"/>	min = 10, max = 720
Re-enable Wind Updates (minutes)	<input type="text" value="10"/>	min = 1, max = 15
Wind Alarm Reporting Interval (minutes)	<input type="text" value="5"/>	min = 2, max = 15

Wind Settings

To modify the **COM Port Settings**, click on the parameter field and type the new value. The **Apply Changes** button will be outlined in red when changes have been entered. Left-click the **Apply Changes** button to save changes. A Changes Applied Successfully message will appear.

The screenshot shows the SMARTSCAN NG² web interface. At the top, there is a navigation bar with the logo and system information: Milepost: 1234.5, Track: Single, Site ID: NONAME, 02/12/2025, 10:20, Battery: 13.0V, Temp: 83F, and a login status of 'Logged in as admin.' with a 'Logout' link. Below this is a menu of configuration options: Train Data, System Status, Configuration (selected), Logs, Maintenance Info, System Functions, Software Update, and Calibration. The main content area is titled 'Configuration' and includes a 'Load Default Setup Parameters' button. On the left is a vertical sidebar with various settings categories, with 'COM Port Settings' highlighted in blue. The main panel displays the 'COM Port Settings' configuration table:

COM Port Settings	
COM1 (Serial Interface)	19200 ▾
COM2 (Not Used)	19200 ▾
COM4 (Not Used)	19200 ▾
COM6 (FlashHost)	57600 ▾
RS485 (Wind Monitor)	9600 ▾
Page Lines	0 min = 0, max = 9999

Below the table is an 'Apply Changes' button.

COM Port Settings

To modify the **AEI Settings**, click on the parameter field and type the new value. The **Apply Changes** button will be outlined in red when changes have been entered. Left-click the **Apply Changes** button to save changes. A Changes Applied Successfully message will appear.

SMARTSCAN NG²

Milepost: 1234.5 Track: Single Site ID: NONAME 02/12/2025, 10:21
Battery: 13.0V Temp: 83F

[Logged in as admin.](#) [Logout](#)

Train Data
System Status
Configuration
Logs
Maintenance Info
System Functions
Software Update
Calibration

Configuration
[Load Default Setup Parameters](#)

- Date/Time
- Site Parameters
- Alarm Settings
- Alarm Settings (Advanced)
- Equipment Settings
- Equipment Settings (Advanced)
- Sunshot Settings
- Frauscher Transducer Offsets
- Message Settings
- Message Settings (Advanced)
- Network Settings
- Wind Settings
- COM Port Settings
- AEI Settings
- Import/Export

AEI Settings

ID Separation	<input type="text" value="2"/>	min = 1, max = 4
Consecutive Reads	<input type="text" value="2"/>	min = 1, max = 4
RF Frequency (MHz)	<input type="text" value="915.000"/> ▾	
RF Attenuation (dB)	<input type="text" value="0"/>	min = 0, max = 10
Multi-Track Tag Filter	<input type="text" value="no"/> ▾	
Antenna 0 Offset	<input type="text" value="0"/>	min = 0, max = 240
Antenna 0 Nearest Txd	<input type="text" value="T01"/> ▾	
Antenna 1 Offset	<input type="text" value="0"/>	min = 0, max = 240
Antenna 1 Nearest Txd	<input type="text" value="T01"/> ▾	

AEI Settings

To **Export** settings, check the box(es) next to the desired settings (**General**, **Network**, **Security**, or **Calibration**). Left-click **Export** to export file in .json format.

To **Import** settings, you must have the appropriate import file available in json format. Check the box(es) for the desired settings you wish to import (**General**, **Network**, **Security**, or **Calibration**). Left-click **Import**, then select the .json file from the browser.

The screenshot shows the SMARTSCAN NG² web interface. At the top, there is a dark blue header with the logo. Below the header, system information is displayed: Milepost: 1234.5, Track: Single, Site ID: NONAME, and a timestamp of 02/12/2025, 10:22. On the right, it shows Battery: 13.1V and Temp: 84F, along with a 'Logged in as admin.' status and a 'Logout' button. A navigation bar contains buttons for Train Data, System Status, Configuration (which is highlighted), Logs, Maintenance Info, System Functions, Software Update, and Calibration. The main content area is titled 'Configuration' and includes a 'Load Default Setup Parameters' button. On the left, a vertical menu lists various settings categories: Date/Time, Site Parameters, Alarm Settings, Alarm Settings (Advanced), Equipment Settings, Equipment Settings (Advanced), Sunshot Settings, Frauscher Transducer Offsets, Message Settings, Message Settings (Advanced), Network Settings, Wind Settings, COM Port Settings, AEI Settings, and Import/Export (which is highlighted in dark blue). The 'Import/Export' section is expanded, showing a list of settings with checkboxes: General Settings (checked), Network Settings, Security Settings, and Calibration Settings. Below these checkboxes are 'Export' and 'Import' buttons.

Import/Export

5.4 System Event Log

The **System Event Log** report is used for diagnostics. As certain system events occur, entries are posted into the event log. Each time an entry is made into this log, it receives an event number, the date and time that the event was recorded, and an event description. Events are listed in chronological order beginning with the most recent event.

To view the system event log, left-click the **Logs** tab. Grab and drag the slider bar to view the full report. See **System Event Log** sample depicted below.

Slider Bar

SMARTSCAN NG²

Milepost: 1234.5 Track: Single Site ID: NONAME 02/12/2025, 10:24 Battery: 13.1V Temp: 88F
Logged in as admin. Logout

Train Data System Status Configuration **Logs** Maintenance Info System Functions Software Update Calibration

Event Log Refresh Log Type Event Log

Event Log Security Log

0001:	[02/12/2025 10:08:00]	(54) - Serial Connection timed out: id-3
0002:	[02/12/2025 09:39:28]	(54) - AUX OUT Relay Cmd: Energize Relay, 0 sec, Train=Non
0003:	[02/12/2025 09:37:52]	(54) - Admin logged in: id-3, serial interface
0004:	[02/12/2025 09:21:54]	(54) - Serial Connection timed out: id-3
0005:	[02/12/2025 08:49:45]	(54) - Admin logged in: id-3, serial interface
0006:	[02/12/2025 08:38:00]	(54) - Serial Connection timed out: id-3
0007:	[02/12/2025 08:13:39]	(54) - Admin logged in: id-3, serial interface
0008:	[02/11/2025 17:15:20]	(54) - Serial Connection timed out: id-3
0009:	[02/11/2025 16:47:54]	(54) - Admin logged in: id-3, serial interface
0010:	[02/11/2025 15:24:56]	(54) - Serial Connection timed out: id-3
0011:	[02/11/2025 15:04:41]	(54) - Default setup loaded (Serial Interface, Setup Menu)
		•
		•
		•
0055:	[10/02/2025 13:13:12]	(47) - Stored train #1
0056:	[10/02/2025 13:13:06]	(47) - Starting Exception Numbers at default
0057:	[10/02/2025 13:13:05]	(47) - Starting Train Numbers at default
0058:	[10/02/2025 13:13:05]	(47) - Train Departure
0059:	[10/02/2025 13:12:07]	(47) - Train Arrival
0060:	[10/02/2025 13:10:54]	(54) - Admin logged in: id-3, serial interface
0061:	[10/02/2025 13:10:11]	(47) - Analyzer: Tag Reader Type MPRR/X detected
0062:	[10/02/2025 13:09:58]	(47) - Analyzer: Analyzer booted up
0063:	[10/02/2025 13:09:55]	(53) - Searching for Velocity
0064:	[10/02/2025 13:09:52]	(58) - Comm Startup
0065:	[10/02/2025 13:09:52]	(58) - Reset cause: Software
0066:	[10/02/2025 13:09:27]	(53) - Rebooting for update
0067:	[10/02/2025 13:09:27]	(53) - System Update successful
0068:	[10/02/2025 13:09:08]	(62) - Processor update complete
0069:	[10/02/2025 13:04:04]	(54) - Admin logged in: id-3, serial interface
0070:	[10/02/2025 11:31:08]	(47) - Train #11 assigned sequence number #11

More All

Delete Download Comm Trap

Click the **“More”** button at the bottom to load more events.

5.5 Maintenance Info

Left-click the **Maintenance Info** tab to view maintenance data. Left-click Change Train Range to change the range of trains used for maintenance calculations. The default range is the last forty trains.

SMARTSCAN NG²

Milepost: 1234.5 Track: Single 02/12/2025, 10:25
Battery: 14.2V Temp: 46F

[Logged in as admin.](#) [Logout](#)

Train Data
System Status
Configuration
Logs
Maintenance Info
System Functions
Software Update
Calibration

Maintenance Information

Statistics accumulated for the last **40** trains. Change Train Range Refresh
 Includes data from the last **3** days.

Scanner Statistics

Scanner	Max	Avg	Resistor		Avg CF	Cold Scanner		Cold Resistor		Align	
			Max	Avg		Cnt	%	Cnt	%	N/E	S/W
East Bearing	39	2	300	225	3	16	40	0	0	-4	-6
West Bearing	46	2	300	174	22	10	25	10	25	1	-2
East Wheel	144	30	289	222	0	0	0	0	0	-1	5
West Wheel	112	11	304	241	0	0	0	0	0	0	5

Transducer Statistics

Total Axles Scanned	14302
Total Txd. Miscounts	0
Percent Miscounts	0.00%
Trains With Miscounts	0
Trains In Sample	40
Percent Trains W/ Miscounts	0.00%

System Statistics

	Battery	Ambient Temp
Avg	14.1	43
Max	14.2	47
Min	14.0	41

Hardware Status

East Bearing Scanner Needs Attention

- 40% had Cold East Bearing Scanner
- Successive Cold East Bearing Scanner Limit Exceeded

Possible Cause: Improper calibration or alignment, dirty optics, stuck shutter, blocked scan path, or defective scanner

West Bearing Scanner Failure

- 25% had Cold West Bearing Scanner
- Successive Cold West Bearing Scanner Limit Exceeded
- 25% had Cold West Bearing Scanner Resistor
- Successive Cold West Bearing Scanner Resistor Limit Exceeded
- 5% had Dead West Bearing Scanner Resistor

Possible Cause: Improper calibration or alignment, dirty optics, stuck shutter, blocked scan path, or defective scanner

5.6 System Functions

Some but not all system functions can be accessed remotely. Left-click the **Systems Functions** tab to view available options. Left-click the corresponding button to initiate the desired function.

SMARTSCAN NG²

Milepost: 1234.5 Track: Single Site ID: NONAME 02/12/2025, 10:41
Battery: 13.1V Temp: 85F

[Logged in as admin.](#) [Logout](#)

Train Data
System Status
Configuration
Logs
Maintenance Info
System Functions
Software Update
Calibration

System Functions

System Test Functions

Broadcast A Test Message Over The Radio
Radio Test

Run Vocabulary Test
Vocabulary Test

Temporarily Inhibit Radio Broadcast
Timed Radio Inhibit

Generate 1kHz Test Tone
Test Tone

Start Manual Train
Test Train

Stored Data Resets

Clear Train Data
Clear Data

Clear Event Log Contents
Clear Log

Reset System Health Statistics
Reset Stats

Load Default Setup Parameters
Load Defaults

Speaker Volume Adjust

Select Speaker Volume Setting
3 ▾
Apply Setting

Maintenance Alert Email List

Add An Address:

Add

Apply Email List Changes
Apply

System Reboot

Reboot System Processors
Reboot Now

Resistor Baseline Data

Scanner	Type	Date	Time	Battery Voltage	Ambient Temp	Status	30	40	50	60	70	80	90	100
Rail 1	Type III	05/16/22	10:49	13.4V	56F	VALID	172	174	178	178	180	182	183	186
Rail 2	Type III	04/28/22	08:26	13.0V	56F	VALID	205	208	209	212	214	215	217	220
Wheel 1	Type III	04/28/22	08:26	13.0V	56F	VALID	316	317	318	318	324	322	326	331
Wheel 2	Type III	04/28/22	08:26	13.0V	56F	VALID	328	330	332	334	335	337	343	345

5.7 Remote Software Update

To perform a remote software update, left-click the **Software Update** tab. This tab is the only way to upload software packages onto the detector. Once a package is on the detector, the user can install it either by using this tab or by using the Serial Interface.

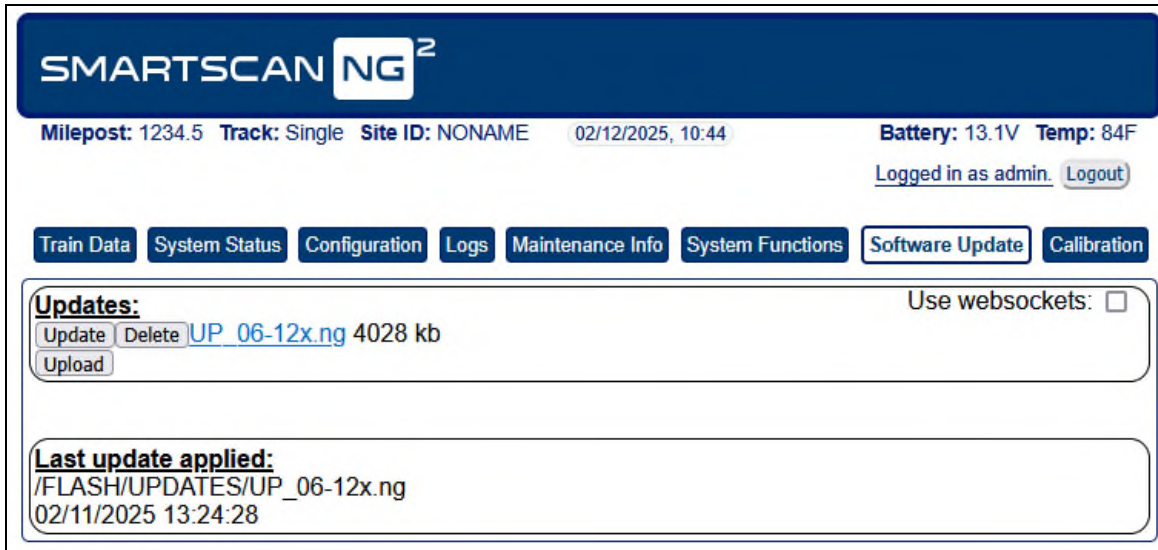

The **Upload** button is used to load a new software package onto the detector for subsequent installation. To upload a new file, left-click on the Upload button. Search for and select a software file on your computer. Only two files can be stored at a time. If there are already two files, you must delete one before uploading another.

When the upload is complete, left-click the **Update** button and follow the instructions to update the software. The **Update** button is used to install a previously uploaded software packet so that it becomes the detector's operating software.

Updating the firmware through the Web Interface (Software Update tab) automatically deletes the train data and the Event Log before installing the update. A confirmation prompt warns of these pending deletions and allows canceling the update to log any needed data. The revised prompt appears below outlined in green.

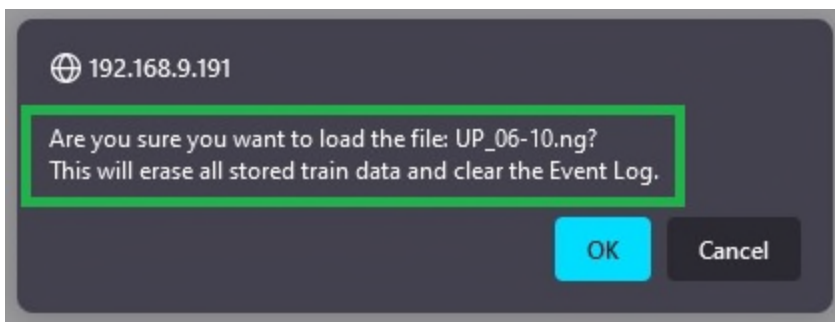

5.8 Auto Calibration

To perform the automatic scanner calibration function, left-click the **Auto Cal** tab.

The screenshot displays the SMARTSCAN NG² web interface. At the top, the header shows the system name and status: Milepost: 1234.5, Track: Single, Site ID: NONAME, 02/12/2025, 10:45, Battery: 13.1V, Temp: 84F, and Logged in as admin. Below the header is a navigation menu with tabs for Train Data, System Status, Configuration, Logs, Maintenance Info, System Functions, Software Update, and Calibration. The main content area is titled "Scanner Auto Calibration" and contains a "Calibration Status" table, a "Start/Stop" button, and a "History" dropdown menu. Below this is the "Frauscher Transducer Calibration" section, which includes radio buttons for selecting the transducer (T01, T02, or Both) and a "Start Calibration" button.

SMARTSCAN NG²

Milepost: 1234.5 Track: Single Site ID: NONAME 02/12/2025, 10:45 Battery: 13.1V Temp: 84F
Logged in as admin. Logout

Train Data System Status Configuration Logs Maintenance Info System Functions Software Update Calibration

Scanner Auto Calibration

Calibration Status

Scanner	Scanner Type	Potentiometer Setting Prev.	Potentiometer Setting Current	Last Calibration Date	Last Calibration Time
North Bearing	III		41	05/16/2022	10:22
South Bearing	III		40	04/28/2022	08:07
North Wheel	III		41	04/28/2022	08:09
South Wheel	III		42	04/28/2022	08:11

Click 'Start' button to begin calibration. ***INSTALL BLACK FILTER BEFORE CALIBRATING TYPE III WHEEL SCANNER***

Start Stop

History

Frauscher Transducer Calibration

Select the transducer to be calibrated:

- T01
- T02
- Both

Start Calibration

Left click the command buttons to **Start/Stop** calibration.

6.0 Producing Reports

The SmartScanNG² system provides:

- Train Summary report
- Train Detail report
- Exception Summary report
- Exception Detail report
- System Status report
- AEI Diagnostic Detail report
- Event Log report

This section shows a sample of each report with a description of each field. It also lists step-by-step instructions on producing each report on-site.

NOTE: The sample reports found in this document should not be interpreted as real-world conditions or activities. These examples are meant to illustrate the general appearance of a given report and provide a reference for the location of report data.

The instructions for each report start with you being at the Main menu, which is described below.

- 1 Plug your computer into the SmartScanNG² serial port COM1.

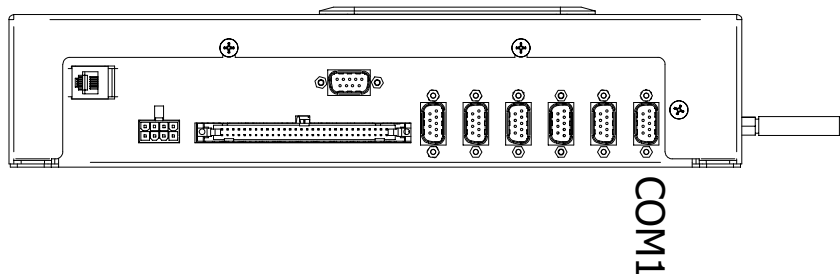

- 2 Turn on your computer.
- 3 Be sure that your computer has installed communications software and that it is set to use full-duplex. The baud rate of your computer must match the baud rate of the selected serial port because they are in direct, one-to-one communication with one another. The baud rate for COM1 was set to 19200 at the factory. If the customer changes this baud rate, your computer must be set to the changed value.

Use your communications software to open a LOG file and capture the whole session to the file. When your session is complete, you may then view what you have done with an editor, print it with a printer, or store it for later retrieval.

- 4 On your computer, open a LOG file.

To display the Main Menu.

5 Press **[Esc]**.

If the system has been set up with security passwords, this prompt appears.

```
Enter password:
```

6 Type the appropriate password to display the Main Menu.

System login with an administrative password allows access to all system menus.

System login with a user password allows access to report menus but restricts access to the setup menu, security menu, and system functions menu.

7 The Main Menu appears.

```
Main Menu - Comm
-----
[A] - Train Summary
[B] - Train Detail
[C] - Exception Summary
[D] - Exception Detail
[E] - System Status Report
[F] - Last Train
[G] - Range of Trains
[H] - Train DSRs
[I] - AEI Diagnostic
[J] - Setup
[K] - Event Log
[L] - System Functions Menu
[M] - Replay Train
[N] - Security Menu
[X] - Exit
```

At the above prompt, you can produce one of the listed reports by selecting the appropriate option.

If a train is at the site when the Main menu is generated, "*** Train Is Present ***" is displayed just above the menu header for the Main menu.

8 When done, close the LOG file.

9 To exit the serial interface and return the system to normal operation, type **X**.

6.1 Train Summary Report

The Train Summary report lists all trains currently stored in the Trains directory. A train number is shown for each train entry so that a Train Detail report may easily be produced for any train listed on the summary.

The report is divided into a header section and a detail section. The header section contains general information about the site. The detail section contains summary information on each train that passed the site.

The SmartScanNG² system calculates a checksum for each train. This checksum is stored with the train data. Later, when the system retrieves this data, it recalculates the checksum. If the two checksums don't match, the Train Summary report so states in the detail section. So, instead of a train record, a checksum-error line will be displayed.

Below is a sample of part of a Train Summary report. The contents of your report will be similar. The version information in the sample below is for illustrative purposes only.

```

=====
Southern Technologies Corporation
Next Generation Detector System
TRAIN SUMMARY
=====
Software Version: UP_06-12x 2025-01-21
MP/KP: 1234.5
Track: Single
Site ID: NONAME

Current Alarm Settings
Absolute..... 200 Carside Slope..... 1.31
Minimum..... 155
Differential.. 115 Cold Journal Temp.. 10
Hot Wheel..... 698

Total Trains: 100
-----
Train#   Date      Time  Cars Axles  TxD Counts  TxD Spikes  D  Speed  Bearing  Bearing  AEI  Amb
         Date      Time  Cars Axles  T01 T02   T01 T02   r Min Max Xit  East West  East West  Tags Temp  Bat
-----
266     02/19/25  22:20  55   454 454 454   0  0  N   6  26  6   29  29   53  57 112  74F 27.9v
265AC   02/19/25  21:24  27   114 114 114   0  0  N  14  18 14   23  22   39  39  53  77F 27.9v
264     02/19/25  16:40  134  544 544 544   0  0  N  27  35 27   17  17   45  48 186  87F 28.0v
263     02/19/25  16:21  112  456 456 456   0  0  N  35  40 35   19  19   56  51 147  88F 27.9v
262     02/19/25  11:40  27   112 112 112   0  0  N  48  48 48   23  24   52  59  52  83F 27.9v
261S*   02/19/25  11:17  27   114 114 114   0  0  S  26  29 26    9   9   29  34  51  84F 27.9v
260     02/19/25  10:21  138  560 560 560   0  0  S  28  40 28   20  21   49  48 193  80F 27.8v
259     02/19/25  08:38  77   320 320 320   0  0  N  29  30 29   20  21   51  50 151  72F 27.8v
258     02/19/25  07:25  48   334 334 334   0  0  N  43  49 45   24  24   48  50  93  67F 27.9v
B257I   02/19/25  04:21  39   266 266 266   0  0  N   9  20 20   28  26   63  55  78  69F 27.9v
256     02/19/25  04:04  28   174 174 174   0  0  N   7  22  7   24  23   43  48  57  69F 27.9v
255     02/19/25  03:34  136  552 552 552   0  0  N  12  48 12   19  19   48  51 181  69F 28.0v
254     02/19/25  02:22  41   272 272 272   0  0  N  30  35 30   30  30   55  55  81  69F 28.0v
      .
      .
      .
=====
Status Code Legend: [DSR Status][Train #][Alarm Status][Correction Factor]

DSR Status      : 'B' = Bearing, 'W' = Wheel, '+' = Both Bearing and Wheel
Alarm Status    : 'A' = Alarms only, 'B' = Both Alarms and Integrity Failures
                 : 'I' = Integrity Failures only, 'S' = System Alarms only, 'T' = Test Train
Correction Factor : 'C' = One or more correction factors greater than 25%.
                 : '*' = Resistor Test results overridden for one or more scanners.
=====

END OF REPORT - Press any key...

```

The table below lists the fields from the header section and the contents of each field.

Heading	Contents of Field
Software Version	The version number and its release date, which is in yyyy/mm/dd format. This firmware resides on the processor modules.
MP/KP	The five-digit milepost/kilometer post of the site. Section 4.0 - Serial Interface tells how to change this value using the MP/KP submenu.
Track	The track designator of the site. For single-track sites, the value is Single. For double-track sites, valid values are 1, 2, 3, 4, 5, and 6. Section 4.0 - Serial Interface tells how to set this value using the Track Designation submenu of the Setup menu.
Sit ID	The unique site identification name. Section 4.0 - Serial Interface tells how to set this value using the Site ID option of the Setup menu.
Current Alarm Settings	<p>The alarm parameters currently defined in the system setup. These values were in place at the time this report was run.</p> <ul style="list-style-type: none"> • The value after Absolute is set by the Absolute option on the Alarm Settings menu. • The value after Differential is set by the Differential option on the Alarm Settings menu. • The value after is set by the option on the Alarm Settings menu. • The value after the Carside Slope is set by the Carside Slope option on the Alarm Settings (Advanced) menu. • The value after Minimum is set by the Carside Minimum option on the Alarm Settings (Advanced) menu. • The value after Cold Rail Temp is set by the Cold Journal Temp option on the Alarm Settings menu. <p>Section 4.0 - Serial Interface tells how to set these values.</p>
Total Trains	The total number of trains visiting the site since the recorded train data was last cleared.

The table below lists the fields from the **detail** section and the contents of each field.

Heading	Contents of Field
Train#	The number that identifies the train in the Trains directory.
Date	The date the train arrived at the site. Date is in mm/dd/yy format.
Time	The time the train arrived at the site. Time is in 24-hour hh:mm format, where 8 a.m. is 08:00, noon is 12:00, 8 p.m. is 20:00, and midnight is 00:00.
Cars	The total number of cars counted by the SmartScanNG ² system.
Axles	The total number of axles counted by the SmartScanNG ² system.
TxD Counts	Under this heading are two columns, one for each gating transducer, containing the total number of hits counted by gating transducers. TO1 is the first gating transducer going north or east from the bearing scanner. It is the gating transducer <u>closest</u> to the bearing scanner. TO2 is the second gating transducer going north or east from the bearing scanner. It is the gating transducer farthest from the bearing scanner.
TxD Spikes	Under this heading are two columns, one for each gating transducer, containing the number of spikes detected by the gating transducers.
Dir	The direction the train was traveling. Valid values are N, S, E, and W.
Speed (mph)	The train's minimum, maximum, and exit speed in miles per hour.
Bearing Average	Under this heading are two columns, one for each bearing scanner, containing the average temperature read by the bearing scanners. If the track orientation is east and west, the bearing scanners are labeled north and south. If the track orientation is north and south, they are labeled east and west.
Bearing Maximum	Under this heading are two columns, one for each bearing scanner, containing the maximum temperature read by the bearing scanners.
Wheel Average	Under this heading are two columns, one for each wheel scanner, containing the average temperature read by the wheel scanners. This field appears only when the Hot Wheel option on the Equipment Settings menu is enabled.
Wheel Maximum	Under this heading are two columns, one for each wheel scanner, containing the maximum temperature read by the wheel scanners. This field appears only when the Hot Wheel option on the Equipment Settings menu is enabled.
AEI Tags	The total number of AEI tags stored. The number of tag pairs found plus those single tags that lack a match. This heading only appears if the AEI subsystem is enabled using the AEI option on the Equipment Settings menu.
Amb Temp	The ambient temperature, in degrees Fahrenheit, at the time the train arrived at the site.
Bat	The system battery voltage at the time the train passed the site.

The Train Summary report contains three unlabeled columns that may contain one-character status codes. A legend listing the available characters and their meanings is printed at the end of these reports. In the Train Summary excerpt below, the three columns have been highlighted and labeled. The following section includes a brief explanation of each column along with a table containing possible values for that column.

A B C

Train#	Date	Time	Cars	Axles	TxD Counts		TxD Spikes		D i	Speed			Bearing Average		Bearing Maximum		AEI Tags	Amb Temp	Bat
					TO1	TO2	TO1	TO2		r	Min	Max	Xit	East	West	East			
266	03/19/25	22:20	55	454	454	454	0	0	N	6	26	6	29	29	53	57	112	74F	27.9v
265A	03/19/25	21:24	27	114	114	114	0	0	N	14	18	14	23	22	39	39	53	77F	27.9v
264	03/19/25	16:40	134	544	544	544	0	0	N	27	35	27	17	17	45	48	186	87F	28.0v
263	03/19/25	16:21	112	456	456	456	0	0	N	35	40	35	19	19	56	51	147	88F	27.9v
262	03/19/25	11:40	27	112	112	112	0	0	N	48	48	48	23	24	52	59	52	83F	27.9v
261S*	03/19/25	11:17	27	114	114	114	0	0	S	26	29	26	9	9	29	34	51	84F	27.9v
260	03/19/25	10:21	138	560	560	560	0	0	S	28	40	28	20	21	49	48	193	80F	27.8v
259	03/19/25	08:38	77	320	320	320	0	0	N	29	30	29	20	21	51	50	151	72F	27.8v
258	03/19/25	07:25	48	334	334	334	0	0	N	43	49	45	24	24	48	50	93	67F	27.9v
B257I	03/19/25	04:21	39	266	266	266	0	0	N	9	20	20	28	26	63	55	78	69F	27.9v
⋮																			

=====
 Status Code Legend: [DSR Status][Train #][Alarm Status][Correction Factor]
 DSR Status : 'B' = Bearing, 'W' = Wheel, '+' = Both Bearing and Wheel
 Alarm Status : 'A' = Alarms only, 'B' = Both Alarms and Integrity Failures
 : 'I' = Integrity Failures only, 'S' = System Alarms only, 'T' = Test Train
 Correction Factor : 'C' = One or more correction factors greater than 25%.
 : '*' = Resistor Test results overridden for one or more scanners.
 =====

(Column A) - Below are the characters that can be printed in the DSR status column of the Train Summary report. This column appears just before the Train# column.

Character	Definition
(blank)	There were no DSR records captured for this train
B	DSR records for bearing scanners were captured for this train.
W	DSR records for wheel scanners were captured for this train.
+	DSR records for bearing and wheel scanners were captured for this train.

(Column B) - Below are the characters that can be printed in the Alarm status column of the Train Summary report. This column appears just after the Train# column and right before the Correction Factor column.

Character	Definition
(blank)	The train did not contain any exception alarms, integrity failures, or system alarms.
A	The train contained exception alarms but no integrity failures.
I	The train contained integrity failures but no exception alarms.
B	The train contained exception alarms and integrity failures.
S	The train did not contain any exception alarms or integrity failures, but did contain system alarms.
T	The train was a test train.

(Column C) - Below are the characters that can be printed in the Correction Factor (CF) status column of the Train Summary report. This column appears just after the Alarm status column and right before the date column.

Character	Definition
(blank)	Resistor test passed.
C	The train had one or more correction factors greater than 25%.
*	The resistor test results were overridden for one or more scanners.

To produce a Train Summary report:

- 1 Using the serial interface, display the Main menu.

```

Main Menu - Comm
-----
[A] - Train Summary
[B] - Train Detail
[C] - Exception Summary
      .
      .
      .

```

- 2 Select **Train Summary**.

The main menu will reappear when the report is complete.

At this time, you can produce another report by selecting the appropriate option.

- 3 When done, close the LOG file.
- 4 To exit the serial interface and return the SmartScanNG² system to normal operation, type **X**.

6.2 Train Detail Report

The Train Detail report provides detailed information on a single train. When choosing this report, you'll be prompted for a train number. When prompted, enter a train number from the Train Summary report. The train number appears under the column titled "Train#" in the detail section of the Train Summary report.

Where wheel scanners are properly installed, wheel temperatures are always recorded, even if the Hot Wheel option is disabled. On the other hand, if the AEI option is disabled during train passage, no AEI information is recorded. If the Carside Slope option is disabled during train passage, no Carside Slope alarms are generated.

Carside Slope alarm detection is enabled/disabled using the Carside Slope option on the Equipment Settings menu. Hot Wheel alarm reporting is enabled/disabled using the Hot Wheel option on the Equipment Settings menu. The AEI subsystem is enabled/disabled using the AEI option on the Equipment Settings menu.

The Train Detail Report can be printed in either extended or abbreviated format. The abbreviated report option is defined in the subsequent section. When printing an extended version of a Train Detail report, a copy of the current system parameters appears at the end of the report. This appended information is almost a complete copy of the System Status report.

Below is a sample of part of an extended Train Detail report. In this example, both the AEI option and the Hot Wheel option on the Equipment Settings menu were enabled at the time the report was requested. The Carside Slope option on the Equipment Settings (Advanced) menu was disabled. Also, both the AEI and Hot wheel options were enabled while the train was passing the site. The contents of your report will be different. The version information in the sample below is for illustrative purposes only.

```

=====
                Southern Technologies Corporation
                Next Generation Detector System
                TRAIN DETAIL
=====
Train#: 412           Axles: 422           Speed           MP/KP: 0020.0
Date: 02/12/25       Cars: 104           Min: 39         Track: 2
Time: 11:30          Direction: West     Max: 41         Temperature: +71F
Site ID: NONAME      Shutters Open: 105 Avg: 39         Battery: 26.1v
                    Length: 5589       Exit: 39
=====
Scanner      Max Avg  Resistor      Transducer      Alarm      Limit  Carside Parm
           Read Req CF      Count Spikes
-----
North Brng  45  14  300 283B  0  TO1: 422      0  Absolute      170  Slope: 1.31
South Brng  42  15  300 284B  0  TO2: 422      0  Differential   115  Minimum: 155
North Whl   32   2  285 280B  0
South Whl   31   1  292 278B  0
Resistor Test Mode: Enabled
Cold Rail Test: All trains
Talker Mode: Talk Freely
=====
Software Version: UP_06-12x 2025-01-21
=====
AEI System Data

Tags Read           Tags Stored: 204
-----
Antenna 0: 103
Antenna 1: 101

-----
System Alarms

None

-----
Integrity Failures

None

-----
Axle Alarm Summary

None

-----
•
•
•
(continued on next page)

```

•
•
•

Announcements Made

" U P Detector Milepost 2 0 Point 0 Track 2 "
 " U P Detector Milepost 2 0 Point 0 Track 2 No Defects Detector Out "

Car	Axle	Rail		Wheel		ON	OFF	PW1	PW2	Alarms	
		North	South	North	South						
1	1	3	1	20	31	52	0	18	18	UPRR	5359
	2	1	0	0	0	52	121	21	21		
	3	0	0	0	0	52	119	19	19		
	4	0	0	0	0	51	812	18	17		
	5	1	0	0	0	51	121	21	20		
	6	0	0	0	16	51	119	19	18		
2	7	2	1	28	28	51	315	21	20	UPRR	9034
	8	0	0	0	0	51	130	21	20		
	9	0	0	0	0	51	120	20	20		
	10	1	0	0	0	51	722	20	20		
	11	1	0	16	0	51	127	16	16		
	12	2	0	24	28	51	121	19	18		
3	13	0	0	0	0	51	306	15	15	UPRR	899
	14	2	0	31	28	51	119	18	18		
	15	1	0	28	20	51	118	18	18		
	16	0	0	0	0	50	800	18	18		
	17	3	1	31	31	51	117	16	16		
	18	0	0	0	0	51	118	17	17		
4	19	23	0	0	0	50	445	16	16	ETTX	853846
	20	24	0	0	0	50	83	15	15		
	21	24	0	28	16	50	1445	18	17		
	22	11	1	31	28	50	82	18	17		
5	23	11	0	0	0	50	581	17	17	ETTX	908330
	24	16	0	0	0	50	77	16	16		
	25	14	0	0	0	49	1426	17	17		
	26	24	0	0	0	49	76	19	18		
6	27	21	0	0	0	49	575	16	16	ETTX	802471
	28	24	0	0	0	49	81	17	16		
	29	23	0	0	0	48	1400	17	17		
	30	14	0	0	0	48	80	17	17		
7	31	23	0	0	0	48	533	16	16	ETTX	702465
	32	23	0	0	0	48	78	14	15		
	33	19	0	0	0	48	1429	17	17		
	34	20	0	0	0	48	78	17	17		

•
•
•

The Train Detail report is divided into three sections. The header section contains general information about the site (like the MP/KP) and some detail information about the specific train (like the train's exit speed) that passed the site. The detail section contains more detailed information (like the bearing and wheel temperatures) about the specific train. In between these two sections is the system-events section, which contains all System Alarms and Axle Alarms associated with the train.

The table below lists the fields from the header section and the contents of each field.

Heading	Contents of Field
Train#	The number that identifies the train in the Trains directory.
Date	The date the train arrived at the site. Date is in mm/dd/yy format.
Time	The time the train arrived at the site. Time is in 24-hour hh:mm format, where 8 a.m. is 08:00, noon is 12:00, 8 p.m. is 20:00, and midnight is 00:00.
Site ID	The unique site identification name.
Axles	The total number of axles counted by the SmartScanNG ² system.
Cars	The total number of cars counted by the SmartScanNG ² system.
Direction	The direction the train was traveling. Valid values are North, South, East, and West.
Shutters Open	The number of seconds it took the train to pass over the site.
Length	The length of train in feet.
Speed	The train's minimum, maximum, average, and exit speeds in miles per hour.
MP/KP	The five-digit milepost/kilometer post of the site. Section 4.0 - Serial Interface tells how to change this value using the MP/KP submenu of the Setup menu.
Track	The track designator of the site. For single-track sites, the value is Single. For double-track sites, valid values are 1, 2, 3, 4, 5, and 6. Section 4.0- Serial Interface tells how to set this value using the Track Designation submenu of the Setup menu.
Temperature	The ambient temperature at the time the train arrived at the site. Temperature is in degrees Fahrenheit.
Battery	The system battery voltage at the time the train passed the site.
Scanner	Location of the bearing and wheel scanners. If the track orientation is east and west, the scanners are labeled north and south. If the track orientation is north and south, they are labeled east and west.
Max	The maximum temperature, above the ambient temperature in degrees Fahrenheit, recorded by a scanner.
Avg	The average temperature, above the ambient temperature in degrees Fahrenheit, calculated from all recorded temperatures from a scanner

Heading	Contents of Field
Resistor Read	The scanner resistor temperature (read after train passage), in degrees Fahrenheit, recorded by the scanner.
Resistor Req	The resistor temperature, in degrees Fahrenheit, required by the scanner to avoid a Cold Resistor or Cold Wheel Scanner Resistor alarm. This value was calculated using the amount of time the shutters were open and the Resistor Test Mode option in effect at the time the train exits the site. If the Resistor Test Mode option is <u>disabled</u> , a zero appears in this field.
	<p>One of five uppercase letters follows the Resistor Req temperature.</p> <ul style="list-style-type: none"> B The baseline resistor integrity test method was used for this train. D The resistor integrity test (that is, the Resistor Test Mode option) was disabled by the user. I The interim resistor integrity test method was used for this train. T For this train, the shutters were open for less than 30 seconds. V For this train, the battery voltage (measured with the shutters open) was less than 12.6 volts (12V system) or 22 volts (24V system). <p>For D, T, and V, the required resistor heat is set to zero (that is, a zero appears in the Resistor Req field). A T or V indicates that the integrity test was not performed due to low voltage or insufficient shutter open time, which could result in an invalid resistor integrity test if it was performed.</p>
CF	The percentage difference between the required resistor value and the value that was actually read. For example, if the required resistor temperature is 180 and the actual resistor temperature is 135 the correction factor would be 25% ($1 - (135 / 180) = .25$), and 25 would appear in this field.
Txdr Counts	The gating transducer designator (either TO1 or TO2) followed by the total number of hits counted by that transducer.
Txdr Spikes	The total number of spikes detected from TO1 or TO2.
Alarm Limit	<p>The Hotbox alarm levels for Absolute and Differential; alarm level; and the Cold Rail Temperature offset. These values were in place at the time the train arrived at the site.</p> <ul style="list-style-type: none"> • The value after Absolute is set by the Absolute option on the Alarm Settings menu. • The value after Differential is set by the Differential option on the Alarm Settings menu. • The value after is set by the option on the Alarm Settings menu. • The value after Cold Rail Temp is set by the Cold Journal Temp option on the Alarm Settings menu. <p>Section 4.0 - Serial Interface tells how to set these values.</p>

Heading	Contents of Field
Carside Params	<p>The Carside Slope alarm parameter values that were in place at the time the train arrived at the site.</p> <ul style="list-style-type: none"> • The value after Slope is set by the Carside Slope option on the Alarm Settings (Advanced) menu. • The value after Minimum is set by the Carside Minimum option on the Alarm Settings menu. <p>Section 4.0 - Serial Interface tells how to set these values.</p>
Resistor Test Mode	<p>The status of the post-train resistor integrity test at the time the train arrived at the site. Valid values (aka modes) are Enabled, and Disabled. Section 4.0 - Serial Interface tells how to set this value using the Resistor Test option on the Equipment Settings (Advanced) menu.</p>
Cold Rail Test	<p>The status of the cold rail test at the time the train arrived at the site. Valid values are "All Trains" and "Long Trains Only."</p>
Software Version	<p>The version number and its release dates, which are in yyyy/mm/dd format. This firmware resides on the processor modules.</p>
AEI System Data	<p>The number of AEI tags read (by antenna0 and antenna1) and the total number of tags stored for the train. Where both tags of a tag pair are operational, each antenna will read one tag of the pair. The total number of tags stored represents the number of tag pairs found plus those single tags that lack a match.</p>

The table below lists the fields from the system-events section and the contents of each field.

Heading	Contents of Field
System Alarms	<p>Lists any System Alarms detected at the time the train passed the site. If none were detected, this header is followed by the word "None." Appendix A - System Alarms describes the conditions and events that the system flags as System Alarms.</p>
Integrity Failures	<p>Lists any Integrity Failures detected at the time the train passed the site. If none were detected, this header is followed by the word "None." Appendix B - Integrity Failures describes the conditions and events that the system flags as Integrity Failures.</p>
Axle Alarm Summary	<p>Lists each Exception Alarm found on the train and the axle on which it was found. If none were found, this header is followed by the word "None."</p>
Announcements Made	<p>Lists the announcements transmitted on the designated radio frequency.</p>

The table below lists the fields from the detail section and the contents of each field.

Heading	Contents of Field
(Unlabeled)	The leftmost column (unlabeled) can contain B, P, W, + (plus sign), or nothing. If "B," at least one bearing was found on the axle that was warmer than the value set by the Bearing DSR Capture Temp option on the Alarm Settings (Advanced) menu. If "P," noise on a pyrometer input (from at least one scanner) was detected and filtered while the axle was passing the site. If "W," at least one wheel was found on the axle that was warmer than the value set by the Wheel DSR Capture Temp option on the Alarm Settings (Advanced) menu. If "+," more than one problem was detected (that is, some combination of B, P, and W was detected). If blank, no warm bearing, warm wheel, or pyrometer noise was detected.
Car	The car number as determined by the firmware.
Axle	The axle number.
Rail	Under this heading are two columns, one for each bearing scanner, containing the temperature read by the bearing scanners. If the track orientation is east and west, the bearing scanners are labeled north and south. If the track orientation is north and south, they are labeled east and west.
Wheel	Under this heading are two columns, one for each wheel scanner, containing the temperature read by the wheel scanners. This heading and the two columns under it appear only when the option on the Equipment Settings menu is <u>enabled</u> .
ON	The number of milliseconds an axle was between the gating transducers.
OFF	The number of milliseconds between axles (when no axle was between the gating transducers).
PW1	The recorded width, in milliseconds, of the pulse generated by gating transducer TO1. Slower trains generate wider pulse widths than faster trains.
PW2	The recorded width, in milliseconds, of the pulse generated by gating transducer TO2. Slower trains generate wider pulse widths than faster trains.
Alarms	Any Exception Alarm found on the given axle.

To produce a Train Detail report:

- 1 Using the serial interface, display the Main menu.

```
Main Menu - Comm
-----
[A] - Train Summary
[B] - Train Detail
[C] - Exception Summary
[D] - Exception Detail
[E] - System Status Report
      .
      .
      .
```

- 2 Select **Train Detail**.

This prompt appears.

```
Enter Train Number:
```

- 3 Type the train number.

If the train number of the train you wish to print has fewer than four digits, press [Enter] after typing the digits.

If you enter an invalid train number, the system prints “Train Not Found,” and the main menu reappears.

- 4 The Main menu reappears after a report is produced.

At this time, you can produce another report by selecting the appropriate option.

- 5 When done, close the LOG file.

- 6 To exit the serial interface and return the SmartScanNG² system to normal operation, type **X**.

6.3 Abbreviated Train Detail Report

The abbreviated Train Detail report is like the extended Train Detail report. However, the abbreviated report doesn't display all the recorded axle data. It only displays axle data for:

The car immediately preceding a car with an alarmed axle.

The car containing the alarmed axle.

The car immediately following the car with the alarmed axle.

For example, assume that a train consisted of 3 locomotives and 20 cars, and Exception Alarms were found on cars 3 and 15. The Abbreviated Train Detail report for this train would only list axle data for cars 2, 3, 4, 14, 15, and 16. These car numbers comprise the alarmed cars themselves and all cars immediately before and immediately after them.

The abbreviated Train Detail Report will look similar to the abbreviated Exception Detail report example in Section 6.6.

To produce an abbreviated Train Detail report:

- 1 Using the serial interface, display the Main menu.

(bkt: When this chapter began, it explained how to access and display the Main Menu.)

```
Main Menu - Comm
-----
[A] - Train Summary
[B] - Train Detail
[C] - Exception Summary
[D] - Exception Detail
[E] - System Status Report
[F] - Last Train
      .
      .
      .
```

- 2 Select **Train Detail**.

This prompt appears.

```
Enter Train Number:
```

- 3 Type the train number.
- 4 If you typed fewer than four digits, press **[Enter]**.

```
Abbreviated? (y/n)
```

- 5 To produce the abbreviated Train Detail report, type **Y**.

If you typed an invalid train number, the system prints "Train Not Found," and the Main menu reappears. If the typed train number is valid, a report for that train is produced.

- 6 The Main menu reappears after a report is produced.

At this time, you can produce another report by selecting the appropriate option.

- 7 When done, close the LOG file.

- 8 To exit the serial interface and return the SmartScanNG² system to normal operation, type **X**.

6.4 Exception Summary Report

The Exception Summary report lists all trains currently stored in the Exceptions directory. (A train is stored in the Exceptions directory if either an Exception Alarm or an Integrity Failure was detected on it as it passed the site.) A train number is shown for each train entry so that an Exception Detail report may easily be produced for any train listed on the summary.

The report is divided into a header section and a detail section. The header section contains general information about the site. The detail section contains summary information on each exception train recorded by the system.

Below is a sample of part of an Exception Summary report. The contents of your report will be similar. The version information in the sample below is for illustrative purposes only.

```

=====
                Southern Technologies Corporation
                Next Generation Detector System
                EXCEPTION SUMMARY
=====
Software Version: UP_06-12x 2025-01-21                      MP/KP: 0159.1
                                                           Track: 1
                                                           Site ID: NONAME

Current Alarm Settings
Absolute..... 170    Carside Slope..... 1.31
                   Minimum..... 155
Differential.. 115    Cold Journal Temp.. 10
Hot Wheel..... 698

Total Trains: 8
-----
                D
                i   Speed
Train# Ref#  Date  Time  Axles r Min Max Xit Alarms
-----
B 12    149 03/20/25 08:39   63 N  7 17 17 East Rail Absolute
B 11    148 03/20/25 08:26  236 S  7 22  7 East Rail

B 10    119 03/19/25 00:09   302 N  6 23  7 West Rail Differential

B 9S    117 03/18/25 21:37   456 N  4 33 13

B 8     103 03/15/25 21:16   42 N  4 15 16 Dragging Equipment
B 7     102 03/15/25 20:58  234 N  3 20  3 Dragging Equipment

B 6     64 03/14/25 06:35   16 S  8 19 17 East Rail
                   West Rail
B 5S    63 03/14/25 06:53   344 S  9 39 49

```

The table below lists the fields from the header section and the contents of each field.

Heading	Contents of Field
Software Version	The version number and its release dates, which is in yyyy/mm/dd format. This firmware resides on the processor modules.
MP/KP	The five-digit milepost/kilometer post of the site. Section 4.0 - Serial Interface tells how to change this value using the MP/KP submenu.
Track	The track designator of the site. Section 4.0 - Serial Interface tells how to set this value using the Track Designator submenu of the Setup menu.
Site ID	The unique site identification name. Section 4.0 - Serial Interface tells how to set this value using the Site ID option of the Setup menu.
Current Alarm Settings	<p>The alarm parameters currently defined in the system setup. These values were in place at the time this report was run.</p> <ul style="list-style-type: none"> • The value after Absolute is set by the Absolute option on the Alarm Settings menu. • The value after Differential is set by the Differential option on the Alarm Settings menu. • The value after Hot Wheel is set by the Hot Wheel option on the Alarm Settings menu. • The value after Carside Slope is set by the Carside Slope option on the Alarm Settings menu. • The value after Minimum is set by the Carside Minimum option on the Alarm Settings (Advanced) menu. • The value after Cold Rail Temp is set by the Cold Journal Temp option on the Alarm Settings (Advanced) menu. <p>Section 4.0 - Serial Interface tells how to set these values.</p>
Total Trains	The total number of trains visiting the site since the recorded train data was last cleared.

The table below lists the fields from the detail section and the contents of each field.

Heading	Contents of Field
	The leftmost column (unlabeled) can contain A, B, I, S, or nothing. If "A," an Exception Alarm was detected on the train. If "I," an Integrity Failure was detected. If "B," both an Exception Alarm and an Integrity Failure were detected. If "S," a System Alarm was detected, but Exception Alarms and Integrity Failures weren't. If blank, no Exception Alarm, Integrity Failure, or System Alarm was detected.
Train#	The number that identifies the train in the Exceptions directory.
Ref#	The number that identifies the train in the Trains directory.
Date	The date the train arrived at the site. Date is in mm/dd/yy format.
Time	The time the train arrived at the site. Time is in 24-hour hh:mm format, where 8 a.m. is 08:00, noon is 12:00, 8 p.m. is 20:00, and midnight is 00:00.
Axles	The total number of axles counted by the SmartScanNG ² .
Dir	The direction the train was traveling. Valid values are N, S, E, and W.
Speed (mph)	The train's minimum, maximum, and exit speeds in miles per hour.
Alarms	A description of the alarms that were detected for the current train.

To produce an Exception Summary report:

- 1 Using the serial interface, display the Main menu.

```

Main Menu - Comm
-----
[A] - Train Summary
[B] - Train Detail
[C] - Exception Summary
[D] - Exception Detail
[E] - System Status Report
      .
      .
      .
  
```

- 2 Select **Exception Summary**.

The main menu will reappear when the report is complete.

At this time, you can produce another report by selecting the appropriate option.

- 3 When done, close the LOG file.
- 4 To exit the serial interface and return the SmartScanNG² system to normal operation, type **X**.

6.5 Exception Detail Report

The Exception Detail report provides detailed information on a single train. When choosing this report, you'll be prompted for a train number. When prompted, enter a train number from the Exception Summary report. The train number appears under the column titled "Train#" in the detail section of the Exception Summary report.

Where wheel scanners are properly installed, wheel temperatures are always recorded, even if the Hot Wheel option is disabled. On the other hand, if the AEI option is disabled during train passage, no AEI information is recorded. If the Carside Slope option is disabled during train passage, no Carside Slope alarms are generated.

Carside Slope alarm detection is enabled/disabled using the Carside Slope option on the Equipment Settings (Advanced) menu. Hot Wheel alarm detection and the AEI subsystem are enabled/disabled using the AEI options, respectively, on the Equipment Settings menu.

The Exception Detail Report can be printed in either extended or abbreviated format. The abbreviated report option is defined in the subsequent section. When printing an extended version of an Exception Detail report, a copy of the current system parameters appears at the end of the report. This appended information is almost a complete copy of the System Status report.

Below is a sample of part of an Exception Detail report when the AEI option was enabled at the time the report was requested. The Carside Slope option was disabled. The contents of your report will be similar.

```

=====
                Southern Technologies Corporation
                Next Generation Detector System
                EXCEPTION DETAIL
=====
Except#: 6                Axles: 98                Speed                MP/KP: 1234.5
    Date: 03/22/25        Cars: 21                Min: 50                Track: Single
    Time: 17:05           Direction: South        Max: 50                Temperature: +50F
Site ID: NONAME          Shutters Open: 39      Avg: 50                Battery: 26.2v
                        Length: 2011                Exit: 50
=====
Scanner      Max Avg  Resistor      Transducer      Alarm      Limit  Carside Parm
           Read Req CF      Count Spikes
-----
East Brng  45  36  300 283B  0  TO1:  98    0  Absolute    170  Slope:  1.31
West Brng  206 38  300 284B  0  TO2:  98    0  Differential 115  Minimum: 155
East Whl   32  2  285 280B  0  Hot Wheel    698
West Whl   31  1  292 278B  0
Resistor Test Mode: Enabled
Cold Rail Test: All trains
Talker Mode: Talk Freely
=====
Software Version: UP_06-12x 2025-01-21
=====
AEI System Data

Tags Read          Tags Stored: 39
-----
Antenna 0: 20
Antenna 1: 19

-----
System Alarms

None

-----
Integrity Failures

None

-----
Axle Alarm Summary

Axle 26 West Rail Absolute
.
.
.

(continued on next page)

```

•
•
•

Announcements Made

" U P Detector Milepost 1 2 3 4 Point 5 "
" <TONE> Defect Detected "
" U P Detector Milepost 1 2 3 4 Point 5 First Hot Box West Rail Axle 2 6 From Head Of Train "
" U P Detector Milepost 1 2 3 4 Point 5 First Hot Box West Rail Axle 2 6 From Head Of Train
Detector Out "

Car Axle Rail Wheel
 East West East West ON OFF PW1 PW2 Alarms

Car Axle	Rail East	Rail West	Wheel East	Wheel West	ON	OFF	PW1	PW2	Alarms
1	1	35	37	27	997	13	12		
	2	35	37	27	74	13	13		
	3	35	37	27	64	13	13		
	4	35	37	27	683	13	12		
	5	35	37	27	64	13	13		
	6	35	37	27	63	13	13		
2	7	36	37	27	193	13	13	NS	9892
	8	34	37	27	74	13	12		
	9	35	37	27	64	13	13		
	10	35	37	27	683	13	13		
	11	35	37	27	64	13	13		
	12	34	37	27	64	13	13		
3	13	34	37	27	192	13	13	NS	8972
	14	35	37	27	74	13	13		
	15	35	38	26	64	13	13		
	16	35	37	27	683	13	12		
	17	34	37	27	64	13	13		
	18	35	37	27	63	13	13		
4	19	35	37	27	192	13	13	FEC	4404
	20	35	37	27	75	13	13		
	21	35	37	27	683	13	13		
	22	35	37	27	64	13	13		
5	23	35	37	27	192	13	13	TTEX	353850
	24	35	37	27	75	13	13		
	25	34	37	27	683	13	12		
B	26	35	206	27	63	13	13	West Rail	Absolute
6	27	34	37	27	192	13	13	CRLE	5123
	28	34	37	27	75	13	13		
	29	35	37	27	683	13	12		
	30	36	37	27	63	13	13		
7	31	36	37	27	193	13	13	TTAX	653662
	32	35	37	27	75	13	13		
	33	35	37	27	683	13	12		
	34	35	37	27	63	13	13		
8	35	34	36	27	193	13	13	TTAX	653843
	36	35	36	27	75	13	13		
	37	35	37	27	683	13	12		
	38	35	37	27	63	13	13		

•
•
•

The extended Exception Detail report is divided into three sections. The header section contains general information about the site (like the MP/KP) and some detail information about the specific train (like the train's exit speed) that passed the site. The system-events section contains all System Alarms and Exception Alarms associated with the train. Lastly, the detail section contains more detailed information (like bearing and wheel temperatures) about the specific train.

The Header section of the Exception Detail report contains the field **Except#**. This number identifies the train in the Exceptions directory. It also identifies the train as represented in the Exception Summary report. The remainder of the fields on this report, in the report header, in the system-events section, and in the details section, are all identical to those found in the regular Train Detail Report. Reference section 6.2 Train Detail Report of this manual for definitions of these fields.

To produce the extended Exception Detail report:

- 1 Using the serial interface, display the Main menu.

```
Main Menu - Comm
-----
[A] - Train Summary
[B] - Train Detail
[C] - Exception Summary
[D] - Exception Detail
[E] - System Status Report
[F] - Last Train
      .
      .
      .
```

- 2 Select **Exception Detail**.

This prompt appears.

```
Enter Train Number:
```

- 3 Type the train number.
- 4 If you typed fewer than four digits, press **[Enter]**.

```
Abbreviated? (y/n)
```

- 5 To produce the extended Exception Detail report, type **N**.
If you typed an invalid train number, the system prints "Train Not Found", and the Main menu reappears. If the typed train number is valid, a report for that train is produced.
- 6 The Main menu reappears after a report is produced.
At this time, you can produce another report by selecting the appropriate option.
- 7 When done, close the LOG file.
- 8 To exit the serial interface and return the SmartScanNG² system to normal operation, type **X**.

6.6 Abbreviated Exception Detail Report

The abbreviated Exception Detail report is like the extended Exception Detail report. However, the abbreviated report doesn't display all the recorded axle data. It only displays axle data for:

- The car immediately preceding a car with an alarmed axle.
- The car containing the alarmed axle.
- The car immediately following the car with the alarmed axle.

For example, assume that a train consisted of 3 locomotives and 20 cars, and Exception Alarms were found on cars 3 and 15. The Abbreviated Exception Detail report for this train would only list axle data for cars 2, 3, 4, 14, 15, and 16. These car numbers comprise the alarmed cars themselves and all cars immediately before and immediately after them.

Below is a sample of part of an abbreviated Exception Detail report. The contents of your report will be similar.

```
Southern Technologies Corporation
Next Generation Detector System
EXCEPTION DETAIL
ABBREVIATED
=====
Except#: 6                      Axles: 98                      Speed                      MP/KP: 1234.5
-----
      Rail      Wheel
Car Axle  East  West  East  West  ON  OFF  PW1  PW2  Alarms
-----
  4  19   34   37   35   28  27  192  13  13  FEC   4404
     20   35   37   35   28  27   75  13  13
     21   35   37   35   31  27  683  13  12
     22   35   37   36   31  27   63  13  13

  5  23   35   37   36   35  27  193  13  13  TTEX 353850
     24   35   37   36   35  27   75  13  13
     25   35   37   36   35  27  683  13  12
  B  26   35  205   36   35  27   64  13  13  West Rail Absolute

  6  27   35   37   36   35  27  193  13  13  CRLE   5123
     28   35   37   36   35  27   75  13  13
     29   35   37   35   28  27  683  13  12
     30   35   37   35   31  27   64  13  13
     .
     .
     .
```

To produce the abbreviated Exception Detail report:

1. Using the serial interface, display the Main menu.

```
Main Menu - Comm
-----
[A] - Train Summary
[B] - Train Detail
[C] - Exception Summary
[D] - Exception Detail
[E] - System Status Report
[F] - Last Train
      .
      .
```

2. Select **Exception Detail**.

This prompt appears.

```
Enter Train Number:
```

3. Type the train number.
4. If you typed fewer than four digits, press **[Enter]**.

```
Abbreviated? (y/n)
```

- 5 To produce the abbreviated Exception Detail report, type **Y**.
If you typed an invalid train number, the system prints "Train Not Found," and the Main menu reappears. If the typed train number is valid, a report for that train is produced.
- 6 The Main menu reappears after a report is produced.
At this time, you can produce another report by selecting the appropriate option.
- 7 When done, close the LOG file.
- 8 To exit the serial interface and return the SmartScanNG² system to normal operation, type **X**.

6.7 System Status Report

The System Status report contains the system's current setup configuration. Once a SmartScanNG² system is set up properly, print this report. Then, keep it in the wayside enclosure for future reference. Should you ever need to set up the system again, you'll have most of the information you'll need on this report. Below is a sample of the top half of a System Status report. The contents of your report will be different.

Southern Technologies Corporation Next Generation Detector System SYSTEM STATUS REPORT			
=====			
Date:02/16/25	Time:14:02	Battery: 11.7v	Ambient Temp.: +76F

SICM Board Rev.....	1.2 or lower	MP/KP.....	1234.5
Time Zone.....	Central	Track.....	Single
Daylight Savings Time.....	Disabled	Track Dir.....	E/W
AC Power.....	On	Site ID.....	NONAME
Talker Mode.....	Talk Freely	Velocity.....	Enabled
AC Surge Suppressor.....	OK		
Software Version			

UP_06-12x 2025-01-21			
Speech Version			

UP Linda 1.1			
Alarm Settings			

Absolute.....	170	Differential.....	117
Hot Wheel.....	900	Cold Journal Counter.....	3
Cold Journal Temp.....	10	Cold Res Counter.....	3
Differential Enabled.....	Yes		
Alarm Settings (Advanced)			

Carside Slope.....	2.30	Carside Minimum.....	120
Res Test: Minimum Rail Avg.....	25	Res Test: Minimum Wheel Avg.....	28
Bearing DSR Capture Temp.....	72	Wheel DSR Capture Temp.....	361
Max Alarms.....	6		
Equipment Settings			

Dragger.....	Yes	Hot Wheel.....	Yes
Hot Bearing.....	Yes	High Load.....	No
Wide Load.....	No	AEI.....	No
Presence Hardware.....	Yes	Advance Transducers.....	No
AC Power Off Monitor.....	Yes	Cold Rail Test Mode.....	All trains
Equipment Settings (Advanced)			

Carside Slope.....	No	Winter Cycle.....	Jan - Jan
Gate Distance.....	24.0 in	Dragger Debounce Time.....	100 ms
Pre Train Dragger Dist.....	0 ft	Pre Train High/Wide Dist.....	0 ft
Presence Timeout Period.....	10 sec	System Voltage.....	24 V
Resistor Test.....	Enabled	Clearance Mode.....	Multiplexed
Clearance Type.....	Trip Wire	Transducer Gain.....	Normal
Transducer Type.....	Frauscher	Rail Size.....	136 (67.46)
North Rail Scanner Offset.....	22 (T01)	South Rail Scanner Offset.....	22 (T01)
North Wheel Scanner Offset.....	0 (T01)	South Wheel Scanner Offset.....	0 (T01)
	.		
	.		
	.		

Below is a sample of the bottom half of a System Status report. The contents of your report will be different. The version information in the sample below is for illustrative purposes only. It doesn't represent any real release of the firmware.

```

      .
      .
      .
Message Settings
-----
Customer Name..... Yes           Axles..... Yes
Speed..... Yes                   Temperature..... Yes
Slow..... No                      Power Off..... No
Length..... No                    Lft/Rt Alarm Ref..... No
Car ID With Alarm..... No

Message Settings (Advanced)
-----
Announce Hot Wheels..... Yes       Announce High/Wide..... Yes
Rebroadcast Time Limit..... 10 min  Rebroadcast DTMF Code..... 001
Num Repeat No Defects..... 1       EOT Repeat Delay..... 1 sec

Network Settings
-----
Use Static Address..... No         Static IP..... 192.168.1.201
Static Mask..... 255.255.255.0     Default Gateway..... 192.168.1.1
DNS Server..... 192.168.1.1        TELNET Port..... 23
FTP Port..... 21                   HTTP Port..... 80
HTTPS Port..... 8080

Sunshots
-----
Sunshot Filter..... Disabled       Scanner Orientation..... 0
Latitude..... 35.0456              Longitude..... -85.3097
Dynamic Scan Window Start..... 10   Dynamic Scan Window End..... 38

Wind Settings
-----
Wind Monitor..... Not Installed     High Wind Alarm Limit..... 50 mph
Display Wind Diagnostics..... No     Wind Poll Interval..... 15 sec
Slow Wind Speed Limit..... 2 mph     Upper Interval Identical Limit..... 30 min
Lower Interval Identical Limit..... 360 min  Wind Gust Interval..... 5 min
Suspicious Temp. Interval..... 720 min  Re-enable Wind Updates..... 10 min
Wind Alarm Reporting Interval..... 5 min

Port Settings
-----
COM1 (Serial Interface)..... Baud 19200 None  COM2 (Not Used)..... Baud 19200 None
COM3 (Velocity)..... Baud 19200 None         COM4 (Not Used)..... Baud 19200 None
COM5 (AEI)..... Baud 19200 None             COM6 (FlashHost)..... Baud 57600 None
RS485 (Wind Monitor)..... Baud 9600 None     Page Lines..... 0

AEI Settings
-----
Tag Reader Type..... None           ID Separation..... 2
Consecutive Reads..... 2            RF Frequency (MHz)..... 915.000
RF Attenuation (dB)..... 0          Multi-Track Tag Filter..... Disabled

Scanner Calibration Date / Digital Potentiometer Settings
-----
Rail 1 Type III..... 01/28/2025 10:22 / 41   Rail 2 Type III..... 01/28/2025 08:07 / 40
Wheel 1 Type III..... 01/28/2025 08:09 / 41  Wheel 2 Type III..... 01/28/2025 08:11 / 42

Resistor Baseline
-----
Rail 1 Type III..... Valid           Rail 2 Type III..... Valid
Wheel 1 Type III..... Valid          Wheel 2 Type III..... Valid

```

The table below lists the fields on the System Status report and the contents of each field.

Heading	Contents of Field
Date	The date at the time this report was generated. Date is in mm/dd/yy format.
Time	The time at the time this report was generated. Time is in 24-hour hh:mm format, where 8 a.m. is 08:00, noon is 12:00, 8 p.m. is 20:00, and midnight is 00:00.
Battery	The system battery voltage at the time this report was generated.
Ambient Temp	The ambient temperature at the time this report was generated. Temperature is in degrees Fahrenheit.
SICM Board Rev	The revision of the 2300-110 System Interface board.
MP/KP	The five-digit milepost/kilometer post of the site.
Time Zone	The time zone that is currently defined in the system setup. Valid values are Eastern, Central, Mountain, and Pacific.
Track	The track designator of the site. For single-track sites, the value is Single. For double-track sites, valid values are 1, 2, 3, 4, 5, and 6.
Daylight Savings Time	Whether daylight-saving time is to be observed or not. If disabled, all times throughout the year are in standard time. If enabled, all times between the second Sunday in March and the first Sunday in November are in daylight-saving time. All other times are in standard time.
Track Dir	The track direction of the site. Valid values are N/S (for north/south) and E/W (for east/west).
AC Power	Indicates if AC power is present.
Site ID	The unique name identifying the sight.
Talker Mode	Indicates the current Talker Mode setting.
Velocity	Indicates if Velocity support is enabled or disabled.
AC Surge Suppressor	Indicates the current status of the AC surge suppressor.
Software Versions	The version number of the firmware and its release dates, which is in yyyy/mm/dd format. This firmware resides on the processor modules.
Speech Version	The version number of the Speech file.

Heading	Contents of Field
Alarm Settings	The alarm parameters and limits as they are currently defined in the system setup. Section 4.0 - Serial Interface tells how to change these parameters and limits using the Alarm Settings menus of the Setup menu.
Equipment Settings	Equipment configuration as currently defined in the system setup. Section 4.0 - Serial Interface tells how to change this configuration using the Equipment Settings menus of the Setup menu.
Messages Settings	Message configuration as currently defined in the system setup. Section 4.0 - Serial Interface tells how to change this configuration using the Messages menus of the Setup menu.
Network Settings	The network parameters as they are currently defined in the system setup. Section 4.0 - Serial Interface tells how to change these parameters using the Network Settings menu of the Setup menu.
Wind Settings	The Wind parameters as they are currently defined in the system setup. Section 4.0 - Serial Interface tells how to change these parameters using the Wind Settings menu of the Setup menu
Port Settings	Communications port parameter settings as currently defined in the system setup. Section 4.0 - Serial Interface tells how to change these parameter settings using COM Port Settings of the Setup menu.
AEI Settings	The AEI parameters as they are currently defined in the system setup. Section 4.0 - Serial Interface tells how to set these values using the AEI Reader Parameters menu of the Setup menu.
Scanner Cal. Date	Date and time each scanner was last calibrated and the associated calibration potentiometer settings for each.
Resistor Baseline	Indicates whether a valid resistor baseline has been acquired for each scanner.

To produce a System Status report:

- 1 Using the serial interface, display the Main menu.

```
Main Menu - Comm
-----
[A] - Train Summary
[B] - Train Detail
[C] - Exception Summary
[D] - Exception Detail
[E] - System Status Report
[F] - Last Train
      .
      .
      .
```

- 2 Select **System Status**.
- 3 After producing the report, you are returned to the Main menu.
At this time, you can produce another report by selecting the appropriate option.
- 4 When done, close the LOG file.
- 5 To exit the serial interface and return the SmartScanNG² system to normal operation, type **X**.

6.8 Last Train Report

The Last Train report is identical to the Train Detail report, except that you don't specify a train number. A report on the most recent train is produced.

To produce a Last Train Report, select the option from the Main Menu.

6.9 Range of Trains Report

The Range of Trains report is a set of Train Detail reports for a range of train numbers. The Train Summary report can be used to get a list of train numbers for trains that are currently stored in the detector.

- 1 Using the serial interface, display the Main menu.

```
Main Menu - Comm
-----
[A] - Train Summary
[B] - Train Detail
[C] - Exception Summary
[D] - Exception Detail
[E] - System Status Report
[F] - Last Train
[G] - Range of Trains
      .
      .
```

- 2 Select **Range of trains**.

A prompt like this appears:

```
Trains stored: 13
Oldest train: 1
Newest train: 13
Enter first train:
Enter a value from 1 to 9999:
```

- 3 Enter a value from 1 to 9999 for the first train, then a value from 1 to 9999 for the last train to produce the report,
At this time, you can produce another report by selecting the appropriate option.
- 4 To exit the serial interface and return the SmartScanNG² system to normal operation, type **X**.

6.10 Train DSRs

Train DSR (Dynamic Scan Rate) records store those temperature samples collected by a scanner that exceed the warm-bearing or warm-wheel trigger level. Only 16 bearing-related and 16 wheel-related DSR records are kept per train. When prompted, type a train number from the Train Summary report. The train number appears under the column titled "Train#" in the detail section of that report. Those trains with DSR records will have a single character status code in column A (see Section 6.1) of the Train Summary Report.

- 1 Using the serial interface, display the Main menu.

```
Main Menu - Comm
-----
      .
      .
[F] - Last Train
[G] - Range of trains
[H] - Train DSRs
      .
      .
      .
```

- 2 Select **Train DSRs**.

A prompt like this appears:

```
Enter train number:
```

- 3 Enter the number of the selected train. A prompt like this appears:

```
Is train from Exception Summary report? (y/n)
Separate by gate period? (y/n)
```

To display DSR samples in the single-line format, answer 'N' to the "Separate by gate period? (y/n)" prompt. A report like this appears:

```
No bearing DSRs stored.

Warmest 16 Wheel DSRs:
Axle 13, North Wheel Scanner:
  8,8,8,8,8,8,8,8,8,8,8,8,8,12,15,21,30,38,52,70,88,112,140,165,190,2
  26,249,292,327,365,403,431,441,448,449,445,441,426,404,383,361,341,
  323,305,292,278,260,249,242,236,234,231,228,224,222,221,220,220,220
  ,219,219,219,220,221,224,228,231,234,236,240,246,253,268,285,295,30
  8,324,339,355,365,372,371,361,350,328,305,283,248,231,199,180,157,1
  36,112,91,74
Axle 13, South Wheel Scanner:
  8,8,8,8,8,8,8,8,8,8,8,8,12,18,26,36,46,66,88,114,146,171,197,236,
  272,310,358,404,448,492,513,527,535,536,531,519,507,487,459,439,414
  ,389,369,349,332,316,305,296,288,283,274,268,262,260,258,256,256,25
  4,254,254,256,256,260,264,268,276,283,289,295,303,313,327,341,357,3
  78,399,421,437,443,448,446,441,427,399,367,334,303,270,238,213,186,
  161,138,112,90
Axle 14, South Wheel Scanner:
  8,8,8,8,8,8,8,8,8,8,8,8,12,21,29,40,55,74,94,128,159,189,230,260,
  306,352,405,456,508,553,593,618,627,629,626,616,590,568,536,509,489
  ,459,439,416,395,375,359,347,334,327,321,313,310,308,306,305,305,30
  4,304,304,305,306,307,310,312,320,325,333,343,353,367,382,400,421,4
  41,458,485,504,512,518,516,509,498,467,437,398,357,321,288,246,222,
  189,163,140,112
```

The display DSR samples by gate period, answer 'Y' to the "Separate by gate period? (y/n)" prompt. Displaying an axle's 96 DSR samples by gate period separates the recorded values into three groups:

- **Pre-gate:** The 24 samples (1-24) recorded immediately before an axle passes between the transducers.
- **In-gate:** The 48 samples (25-72) recorded as an axle passes between the transducers.
- **Post-gate:** The 24 samples (73-96) recorded immediately after an axle passes between the transducers.

A report like this appears:.

Warmest 16 Bearing DSRs:

Axle 1, North Bearing Scanner:

Pre-gate : 1,1

In-gate :

1,1,1,1,1,1,1,1,1,1,1,1,1,1,1,1,1,1,2,5,10,17,26,31,41,52,61,71,79,87,93,96,98,97,96,93,89,84,78,71,64,56,44,34,24,21,15,10

Post-gate: 6,5,3,2,1

Axle 6, South Bearing Scanner:

Pre-gate : 0,0

In-gate :

0,0,0,0,0,0,0,0,0,0,0,0,0,0,0,0,0,0,1,2,6,12,22,29,40,53,64,77,89,99,107,113,117,117,117,117,113,108,103,95,86,78,65,53,40,29,25

Post-gate: 16,11,7,5,2,2,1,1,0,0,0,0,0,0,0,0,0,0,0,0,0,0,0,0

Axle 8, South Bearing Scanner:

Pre-gate : 1,1

In-gate :

1,1,1,1,1,1,1,1,1,1,1,1,1,1,1,1,1,1,2,5,8,16,27,35,48,63,77,91,106,116,124,131,136,138,137,134,130,124,117,110,102,91,76,61,46,34,29

Post-gate: 20,13,8,6,3,2,2,1,1,1,1,1,1,1,1,1,1,1,1,1,1,1,1,1

Warmest 16 Wheel DSRs:

Axle 9, North Wheel Scanner:

Pre-gate : 8,8,8,8,8,8,8,8,8,8,8,8,8,8,12,15,21,30,38,52,70,88,112,140,165

In-gate :

190,226,249,292,327,365,403,431,441,448,449,445,441,426,404,383,361,341,323,305,292,278,260,249,242,236,234,231,228,224,222,221,220,220,220,219,219,219,220,221,224,228,231,234,236,240,246,253

Post-gate:

268,285,295,308,324,339,355,365,372,371,361,350,328,305,283,248,231,199,180,157,136,112,91,74

-
-
-

6.11 AEI Diagnostic Detail Report

The AEI Diagnostic Detail report provides detailed information that can be useful in troubleshooting AEI-related problems. When choosing this report, you'll be prompted for a train number. Type a train number from the Train Summary report. The train number appears under the column titled "Train#" in the detail section of that report.

The AEI subsystem is enabled/disabled using the AEI option on the Equipment Settings menu. If the AEI option is disabled during train passage, no AEI information is recorded.

Below is a sample of part of an AEI Diagnostic Detail report when the AEI option was enabled while the specified train was passing the site. The contents of your report will be similar.

The AEI Diagnostic Detail report is divided into two sections. The header section contains general information about the site (like the MP/KP) and some detail information about the specific train (like the train's exit speed) that passed the site. The detail section contains AEI information recorded from the AEI tags mounted on the train.

Southern Technologies Corporation
Next Generation Detector System
AEI Diagnostic

```
=====
Train#: 287                      Speed: 42MPH                      MP/KP: 1234.5
   Date: 03/16/25                 Axles: 280                      Track: Single
   Time: 12:47                    Direction: North                 Temperature: +86F
Length: 6577                      Shutters Open: 109              Battery: 27.9v
=====
```

AEI System Data

```
Tags Read: 81                    Length: 6843
Antenna 0: 40                    Axles: 276
Antenna 1: 41
```

```
=====
Software Version   Package: UP_06-12x 2025-01-21
=====
```

```
-----
TMSTMP Axle Truck On Off PW1 PW2
00000 Car=1, Axles=6, Trks=2, Tags=1, Spd=45, Len=71, Ant0Window=00000|00350
00011 1 1 29 0 13 14
00105 2 1 29 66 11 12
00203 3 1 29 68 12 13

00679 *UP 8046 side=L trk=2 len=73 axls=6 S|5|0|2 hs0= 0 hsl= 4 flags=201
00691 4 2 29 458 12 12
00788 5 2 30 67 13 13

00885 6 2 29 67 12 12
00986 CarEnd= 1, flags=2, Ant1Window=00594|00986

00987 Car=2, Axles=6, Trks=2, Tags=2, Spd=45, Len=72, Ant0Window=00987|01426
01086 7 3 29 171 11 12
01184 8 3 29 67 12 12
01281 9 3 29 67 12 13
01319 *UP 5386 side=L trk=3 len=73 axls=6 S|L|0|2 hs0= 3 hsl= 9 flags=111

01765 UP 5386 side=R trk=4 len=73 axls=6 S|L|0|2 hs0= 3 hsl= 9 flags=224
01770 10 4 29 458 12 12
01867 11 4 29 67 12 13
01965 12 4 29 67 13 13
02044 CarEnd= 2, flags=6, Ant1Window=01673|02044

02045 Car=3, Axles=8, Trks=4, Tags=2, Spd=45, Len=206, Ant0Window=02045|02334
02122 13 5 29 128 12 11
02207 14 5 29 55 13 13
02215 *DTTX721666 side=R trk=5 len=204 axls=8 S|R|1|2 hs0= 8 hsl=16 flags=111

03053 15 6 29 817 12 12
03143 16 6 29 59 12 13

03996 17 7 29 823 14 14
04085 18 7 29 58 13 13

04933 19 8 29 818 11 12
04937 DTTX721666 side=L trk=8 len=204 axls=8 S|R|2|2 hs0= 8 hsl=16 flags=224
05017 20 8 29 54 12 12
05077 CarEnd= 3, flags=5, Ant1Window=04849|05077
.
.
.
```

The table below lists the fields from the header section and the contents of each field.

Heading	Contents of Field
Train#	This number identifies the train in the Trains directory.
Date	The date the train arrived at the site. Date is in mm/dd/yy format.
Time	The time the train arrived at the site. Time is in 24-hour hh:mm format, where 8 a.m. is 08:00, noon is 12:00, 8 p.m. is 20:00, and midnight is 00:00.
Length	The length of the train in feet as calculated from the car lengths read from the recorded AEI tags (as opposed to the train length the detector calculates from the ON/OFF times as the train passes).
Speed	The train's exit speed in miles per hour.
Axles	The total number of axles as calculated from the axle counts read from the recorded AEI tags (as opposed to the axle count the detector calculates from the transducer pulses as the train passes).
Direction	The direction the train was traveling. Valid values are North, South, East, and West.
Shutters Open	The number of seconds it took the train to pass over the site.
MP/KP	The five-digit milepost/kilometer post of the site.
Track	The track designator of the site. For single-track sites, the value is Single. For double-track sites, valid values are 1, 2, 3, 4, 5, and 6.
Temperature	The ambient temperature at the time the train arrived at the site. Temperature is in degrees Fahrenheit.
Battery	The system battery voltage at the time the train passed the site.
Tags Read	Total number of tags read from Antenna 0 and Antenna 1.
Antenna 0	Total number of tags read from Antenna 0.
Antenna 1	Total number of tags read from Antenna 1.
Software Version	The version number of the firmware and its release dates, which is in yyyy/mm/dd format. This firmware resides on the processor modules.

The following excerpt is from the detail section of the AEI Diagnostic report.

```

      •
      •
      •
TMSTMP  Axle  Truck  On  Off  PW1 PW2
00000 Car=1, Axles=6, Trks=2, Tags=1, Spd=45, Len=71, Ant0Window=00000|00350
00011    1    1    29    0   13 14
00105    2    1    29   66   11 12
00203    3    1    29   68   12 13

00679  *UP  8046 side=L trk=2 len=73 axls=6 51|5|0|2 hs0= 0 hs1= 4 flags=201
00691    4    2    29  458   12 12
00788    5    2    30   67   13 13
00885    6    2    29   67   12 12
00986 CarEnd= 1, flags=2, Ant1Window=00594|00986
      •
      •
      •

```

The table below lists the fields from the detail section and the contents of each field.

Heading	Contents of Field
TMSTMP	The timestamp of the recorded event. Indicates the number of milliseconds elapsed since the train was first detected by the system.
Axle	The sequential number assigned by the SmartScanNG ² to a railcar axle. Axle numbering starts with 1 and increases through to the end of the train.
Truck	The sequential number assigned by the SmartScanNG ² to a railcar truck (wheel assembly). Truck numbering starts with 0 and increases through to the end of the train. Each axle recorded is associated with a truck – axles are grouped by trucks.
ON	The number of milliseconds an axle was between the gating transducers.
OFF	The number of milliseconds between axles (when no axle was between the gating transducers).
PW1	The recorded width of the pulse generated by gating transducer TO1. Slower trains generate wider pulse widths than faster trains.
PW2	The recorded width of the pulse generated by gating transducer TO2. Slower trains generate wider pulse widths than faster trains.

The AEI Diagnostic report has one line of data for every AEI tag recorded. See highlighted data line in the example below.

```

      .
      .
      .
00000 Car=1, Axles=6, Trks=2, Tags=1, Spd=45, Len=71, Ant0Window=00000|00350
00011   1   1   29   0  13  14
00105   2   1   29  66  11  12
00203   3   1   29  68  12  13

00679 *UP 8046 side=L trk=2 len=73 axls=6 51|5|0|2 hs0= 0 hs1= 4 flags=201
00691   4   2   29 458  12  12
00788   5   2   30  67  13  13
00885   6   2   29  67  12  12
00986 CarEnd= 1, flags=2, Ant1Window=00594|00986
      .
      .
      .

```

The table below defines the relevant fields in the AEI tag portion of car data.

Field Value	Field Definition
00679	Timestamp of tag read.
UP 8046	AEI vehicle identification
side=L	The side indicator field read from the tag.
trk=2	Truck two of car.
len=73	Car length field read from the tag.
axls=6	The axle count field read from the car.
51 5 0 2	51 is the Data Format Code. 5 is the Equipment Group Code (5 = locomotive). 0 is the Platform Code. 2 is the Tag Type.
hs0= 0	Handshakes from antenna-0 equals zero.
hs1=4	Handshakes from antenna-1 equals four.
flags=201	Diagnostic code (for STC use).

To produce an AEI Diagnostic report:

- Using the serial interface, display the Main menu.

```

      .
      .
[H] - Train DSRs
[I] - AEI Diagnostic
[J] - Setup
[K] - Event log
      .
      .

```

- Select **AEI Diagnostic**.

This prompt appears.

```

Enter Train Number:

```

- Type the train number. This prompt appears.

```

Print raw tag data? (y/n)

```

Type N to print the decoded tag information. Type Y to print the raw tag data.

Decoded Data Example:

TTEX353850 side=R trk=10 len=187 axls=8 S|R|1|2 hs0=18 hs1= 5 flags=224

Raw Data Example:

06504 FWN;%9CJ.SD0 (NAS trk= 10 hs0=18 hs1=05 flags=224

If the train number of the train you wish to print is fewer than four digits, press [Enter] after typing the digits.

If you enter an invalid train number, the system prints "Train not found," and the main menu reappears.

- 4 To return to the Main menu after a report is produced, press any key.
At this time, you can produce another report by selecting the appropriate option.
- 5 When done, close the LOG file.
- 6 To exit the serial interface and return the SmartScanNG² system to normal operation, type **X**.

6.12 Event Log Report

The Event Log report is used for diagnostics. As certain system events occur, entries are posted to the event log. Log entries contain a timestamp which reflects the time at which the entry was posted to the log, a reference number for the system task that triggered the event, and a description of the event.

Entries in the Event Log are listed in chronological order, beginning with the most recent event. They can be deleted with the Clear Event Log option on the System Functions Menu.

Below is a sample of part of an Event Log report. The contents of your report will be similar. Each line of text contains these fields.

- The date at which the event was recorded (date is in mm/dd/yyyy format)
- The time at which the event was recorded (time is in 24-hour hh:mm:ss format, where 8 a.m. is 08:00:00, noon is 12:00:00, 8 p.m. is 20:00:00, and midnight is 00:00:00)
- The software task reference number (used for diagnostic purposes)
- The event description

Log: /FLASH/SYSTEM/logs/EVENTLOG.txt

```
-----  
[03/21/2025 15:47:28] (55) - Admin logged in: id-23, telnet ip-184.174.165.45  
[03/21/2025 15:47:08] (55) - Telnet Connection timed out: id-23  
[03/21/2025 15:36:20] (55) - Admin logged in: id-23, telnet ip-184.174.165.45  
[03/21/2025 15:36:06] (55) - User login failed, telnet ip-184.174.165.45  
[03/21/2025 15:32:36] (48) - Stored train #288  
[03/21/2025 15:32:30] (48) - Train Departure  
[03/21/2025 15:30:58] (55) - Telnet Connection timed out: id-28  
[03/21/2025 15:29:58] (48) - Train Arrival  
[03/21/2025 14:56:48] (55) - Admin logged in: id-28, telnet ip-184.174.165.45  
[03/21/2025 13:26:49] (55) - Telnet Connection timed out: id-27  
[03/21/2025 13:13:30] (55) - Admin logged in: id-27, telnet ip-184.174.165.45  
[03/21/2025 12:49:50] (48) - Stored train #287  
[03/21/2025 12:49:46] (48) - Train Departure  
[03/21/2025 12:47:49] (48) - Train Arrival  
[03/21/2025 12:24:22] (48) - Stored train #286  
[03/21/2025 12:24:14] (48) - Train Departure  
[03/21/2025 12:23:05] (48) - Train Arrival  
[03/21/2025 12:04:12] (55) - Telnet Connection timed out: id-27  
.  
.  
.
```

To produce an Event Log report:

- 1 Using the serial interface, display the Main menu.

```
.  
.  
.  
[H] - Train DSRs  
[I] - AEI Diagnostic  
[J] - Setup  
[K] - Event log  
.  
.  
.
```

- 2 Select the **Event Log**.

The Main menu reappears after the report has been completed.

At this time, you can produce another report by selecting the appropriate option.

- 3 When done, close the LOG file.
- 4 To exit the serial interface and return the SmartScanNG² system to normal operation, type **X**.

7.0 Radio Announcements

Currently, the two ways of reporting defects are:

- Announcements made via the road channel
- Reports, which may be printed to provide detailed defect information

This section describes radio announcements. The prior section described reports.

Radio announcements consist of a set of predefined spoken messages, with each message triggered by a particular event or set of events. The message formats and announcement criteria are covered below.

In the examples that follow, the message " U P Detector " is announced because it was enabled using the **Customer Name option** on the Messages menu. **Section 4.0 - Serial Interface** tells how to enable and disable this message.

Anytime a message needs to be announced, the expanded holdoff logic kicks in, and the process is as follows:

- 1 Check the Holdoff line.
The Holdoff line is enabled when the road channel is busy.
- 2 If the Holdoff line is free and has been free for at least two seconds, announce your messages and skip the remaining steps.
- 3 If the Holdoff line is currently in use, start the Holdoff timer and begin monitoring the Holdoff line. The maximum amount of time the system delays spoken announcements while waiting for a busy radio channel to clear is 40 seconds.
- 4 If the Holdoff line frees up before the Holdoff timer expires, return to step 1.
- 5 If the Holdoff timer expires without the Holdoff line ever becoming free, announce your messages.

7.1 Arrival Messages

The Arrival Message is used to announce train arrival at the site. Its use is optional. Whether or not a site announces the Arrival Message is determined by the current value of the Talker Mode configuration option. If the Talker Mode is set to Talk Freely or Talk Reduced, the Arrival Message will be announced. If the Talker Mode is set to Talk On Defect Only, the Arrival Message will not be announced. **Section 4.0 Serial Interface** tells how to change the Talker Mode option settings.

The format of this announcement is:

[customer name] Milepost (mile) [track indicator]

At a multitrack site, the "track indicator" represents the position in the message text that the track designator (such as "Track Two") is inserted into the announcements. At a single-track site, no message text is inserted for the track indicator.

For example, at a single-track site, the announcement is like this. In this example, milepost 359.4 was used.

```
U P Detector  
Milepost 3-5-9 point 4
```

At a multitrack site, the announcement is like this. In this example, milepost 297.1 was used.

```
U P Detector  
Milepost 2-9-7 Point 1  
Track Two
```

The arrival message is announced once per train.

7.2 Real-Time Messages

Real-time messages are announcements that occur as the train is passing over the site. They are announced using a 1000-hertz tone. When the first alarm is detected, the tone is issued, followed by the words "defect detected." Subsequent alarm announcements do not include the words "defect detected." Real-time messages for Dragging Equipment, High Load, and Wide Load alarms include the type of alarm found and the axle number closest to the detected alarm. One tone is issued for each alarm detected up to and including twice the maximum number of alarms specified using the **Max Alarms option** on the Alarm Settings (Advanced) submenu.

For example, at a site having five alarms (Hotbox and Hot Wheel only), the announcement is like this. For this example, the maximum number of alarms was set to a value greater than two.

```
( tone )  
Defect Detected  
( tone )  
( tone )  
( tone )
```

(tone)

At a site having Dragging Equipment, High Load, and Wide Load alarms, the announcement is like this.

(tone)

Defect Detected

Dragging Equipment Near-Axle-1-2

(tone)

High Load Near-Axle-1-4

(tone)

Wide Load East-Rail Near-Axle-1-6

At a site having Hotbox, Dragging Equipment, High Load, Wide Load, and Hot Wheel alarms, the announcement is like this.

(tone)

Defect Detected

(tone)

Dragging Equipment Near-Axle-1-2

(tone)

High Load Near-Axle-1-4

(tone)

Wide Load East-Rail Near-Axle-1-6

(tone)

When a catastrophic transducer failure occurs in conjunction with an auxiliary alarm, the word "detected" follows the alarm type.

For example, at a site with a malfunctioning TO1 transducer and active Dragging Equipment and High Load outputs within the first three recorded axles, the announcement is like this.

(tone)

Defect Detected

Dragging Equipment Detected Near-Axle-1-2

(tone)

High Load Detected Near-Axle-1-4

The **Clearance Mode** option on the Equipment Settings (Advanced) submenu lets you pick how you want a clearance alarm to be announced. Select Multiplexed when a single tripwire is used for both high-load and wide-load detection. Select Separate when each high-load and the wide-load detector has its own detection hardware. All of the real-time messages shown above correspond to a site configured for a Clearance Mode of **Separate**. At a site configured for a Clearance Mode of **Multiplexed**, the announcement is like this.

(tone)

Defect Detected

High-Wide Near-Axle-1-2

When Dragging Equipment, High Load, or Wide Load detector outputs are active as a train enters the site, "Detector Malfunction" messages appear in the real-time announcements, preceding any real-time announcements for alarms associated with an axle. A separate message appears for each active alarm type. If both Wide-Load outputs are active as a train enters a site, only one "Wide-Load Detector Malfunction" message is announced.

For example, at a single-track site with the Dragging-Equipment detector active as the train arrives, the announcement is like this.

```
(tone)
Dragging Equipment Detector Malfunction
```

At a single-track site with the High-Load and one or both Wide-Load detectors active as the train arrives, the announcement is like this.

```
(tone)
High-Load Detector Malfunction
(tone)
Wide-Load Detector Malfunction
```

At a single-track site having three Hotbox alarms, and with the Dragging-Equipment, High-Load, and one or both Wide-Load detectors active as the train arrives, the announcement is like this.

```
(tone)
Dragging Equipment Detector Malfunction
(tone)
High Load Detector Malfunction
(tone)
Wide Load Detector Malfunction
(tone)
Defect Detected
(tone)
(tone)
```

7.3 Post-Train Messages

Post-train (end-of-train) announcements are given after the train has left the site, and all the recorded train data has been processed by the SmartScanNG².

These messages consist of three distinct scenarios:

- Exception Alarms not detected and Integrity Failures not detected
- Exception Alarms not detected and Integrity Failures detected
- Exception Alarms detected

Exception Alarms are associated with axles. There are 8 of them. They are the Absolute, Carside Slope, Differential, Dragging-Equipment, High-Load, Hot Wheel, Pyrometer Saturation, and Wide-Load alarms.

The four types of **Hotbox alarms** (hot bearing alarms) are Absolute alarms, Differential alarms, Pyrometer Saturation alarms, and Carside Slope alarms. When one of these four alarms occurs, a Hotbox alarm is announced.

Integrity Failures indicate conditions in which the integrity of the system, and its ability to record train data accurately, may be compromised. See Appendix B for a listing of the Integrity Failures supported by the SmartScanNG².

```
Messages Settings
-----
[A] - Axles ..... No
[B] - Speed ..... No
[C] - Temperature ..... No
[D] - Length ..... No
[E] - Slow ..... Yes
[F] - Power Off ..... Yes
[G] - Customer Name ..... Yes
[H] - Lft/Rt Alarm Ref ..... No
[I] - Car ID With Alarm ..... No
[J] - Advanced
[X] - Exit
```

The above-highlighted options on the Messages submenu are used to affect the phrases broadcast to a passing train.

Below is the Messages Settings (Advanced) submenu. The options on this submenu are used to enabled or disable the Hot Wheel and High/Wide announcements and to modify the parameters associated with the Rebroadcast function and the announcement of EOT (end of train) messages.

```
Messages Settings (Advanced)
-----
[A] - Announce Hot Wheels ..... Yes
[B] - Announce High/Wide ..... Yes
[C] - Rebroadcast Time Limit .... 10 min
[D] - Rebroadcast DTMF Code ..... 001
[E] - Num Repeat No Defects ..... 1
[F] - EOT Repeat Delay ..... 1 sec
[X] - Exit
```

In the examples that follow, not all ancillary messages are shown. This is because only axle count and train speed were enabled. Site ambient temperature, train length, and power off were disabled. **Section 4.0 - Serial Interface** tells how to enable and disable these messages using the Messages submenu.

7.3.1 Nothing Detected

When neither an Exception Alarm nor an Integrity Failure is detected, the no-defects message is announced. The format of this announcement is:

```
[U P Detector Milepost (mile) [track indicator] No Defects (pause)]
[U P Detector Milepost (mile) [track indicator] No Defects (pause)]
U P Detector Milepost (mile) [track indicator] No Defects
[ancillary messages]
Detector Out
```

By using the **Num Repeat No Defects and EOT Repeat Delay** option on the Messages Settings (Advanced) submenu, you can customize the number of times the detector makes the no-defects announcement and the number of seconds the detector pauses between each of the no-defects messages. Any ancillary messages and the detector-out message occur only once and follow the final no-defects announcement.

For example, at a single-track site with the **Num Repeat No Defects** option set to one, the announcement is like this.

```
U P Detector
Milepost 3-2-1 point 4
No Defects
Total Axles 1-0-0
Train Speed 4-5 M-P-H
Detector Out
```

At a single-track site with the **Num Repeat No Defects** option set to three and the **EOT Repeat Delay** option set to five, the announcement is like this.

```
U P Detector
Milepost 1-7-9 point 5
No Defects
(5-second pause)
U P Detector
Milepost 1-7-9 point 5
No Defects
(5-second pause)
U P Detector
Milepost 1-7-9 point 5
No Defects
Total Axles 1-0-2
Train Speed 5-3 M-P-H
Detector Out
```

At a double-track site with the **Num Repeat No Defects** option set to one, the announcement is like this.

```
U P Detector
Milepost 2-5-4 point 5
Track-1
No Defects
Total Axles 1-0-0
Train Speed 4-5 M-P-H
Detector Out
```

If the system's milepost setting is "0000.0," the firmware eliminates both the word "milepost" and the milepost number from the message. The rest of the message announces as shown above.

7.3.2 Only an Integrity Failure Detected

Integrity failures are caused when the system determines that a condition exists that could prevent proper scanning of a train. They indicate an unusual operating condition that may require maintenance. Integrity failures appear in the header of Train Detail reports and Exception Detail reports.

When no Exception Alarms are detected, but an Integrity Failure is detected, only Integrity Failure is announced. The format of this announcement is:

```
U P Detector Milepost (mile) [track indicator] Integrity Failure
U P Detector Milepost (mile) [track indicator] Integrity Failure
[ancillary messages]
Detector Out
```

For example, at a double-track site, the announcement is like this.

```
U P Detector
Milepost 2-5-4 point 5
Track-1
Integrity Failure
U P Detector
Milepost 2-5-4 point 5
Track-1
Integrity Failure
Total Axles 1-2-4
Train Speed 4-8 M-P-H
Detector Out
```

If the system's milepost setting is "0000.0," the firmware eliminates both the word "milepost" and the milepost number from the message. The rest of the message announces, as shown above.

7.3.3 Exception Alarms Detected

When one or more Exception Alarms are detected, the alarms are announced. The format of this announcement is:

```
U P Detector Milepost (mile) [track indicator] [alarm announcements]
U P Detector Milepost (mile) [track indicator] [alarm announcements]
[ancillary messages]
Detector Out
```

For example, at a single-track site having one Hotbox alarm, the announcement is like this.

```
U P Detector
Milepost 3-2-1 point 4
First-Hotbox West-Rail Axle-7-5 From-Head-of-Train
U P Detector
Milepost 3-2-1 point 4
First-Hotbox West-Rail Axle-7-5 From-Head-of-Train
Total Axles 1-0-0
Train Speed 4-5 M-P-H
Detector Out
```

At a single-track site having one Hot Wheel alarm, the announcement is like this.

```
U P Detector
Milepost 3-2-1 point 4
First-Hot Wheel West-Rail Axle-7-5 From-Head-of-Train
U P Detector
Milepost 3-2-1 point 4
First-Hot Wheel West-Rail Axle-7-5 From-Head-of-Train
Total Axles 1-0-0
Train Speed 4-5 M-P-H
Detector Out
```

At a single-track site having two Hotbox alarms, the announcement is like this.

```
U P Detector
Milepost 3-2-1 point 4
First-Hotbox West-Rail Axle-7-5 From-Head-of-Train
Second-Hotbox East-Rail Axle-8-0
U P Detector
Milepost 3-2-1 point 4
First-Hotbox West-Rail Axle-7-5 From-Head-of-Train
Second-Hotbox East-Rail Axle-8-0
Total Axles 1-0-0
Train Speed 4-5 M-P-H
Detector Out
```

At a single-track site having one Hotbox alarm and one Dragging-Equipment alarm, the announcement is like this.

```
U P Detector
Milepost 3-2-1 point 4
First-Hotbox West-Rail Axle-7-5 From-Head-of-Train
First-Dragging-Equipment Near-Axle-8-4
U P Detector
Milepost 3-2-1 point 4
First-Hotbox West-Rail Axle-7-5 From-Head-of-Train
First-Dragging-Equipment Near-Axle-8-4
Total Axles 1-0-0
Train Speed 4-5 M-P-H
Detector Out
```

When the number of detected alarms exceeds the **Max Alarms** option on the Alarm Settings (Advanced) submenu, a “Multiple ... Detected From Axle ... To End of Train” message follows the alarm announcements.

At a single-track site having more Dragging-Equipment alarms than the maximum alarm setting and a detected Integrity Failure, the announcement is like this. For this example, the maximum number of alarms was set to two.

```
U P Detector
Milepost 3-2-1 point 4
First-Dragging-Equipment Near-Axle-1-2 From-Head-of-Train
Second-Dragging-Equipment Near-Axle-1-4
Multiple-Dragging-Equipment Detected From-Axle-1-8 To-End-of-Train
U P Detector
Milepost 3-2-1 point 4
First-Dragging-Equipment Near-Axle-1-2 From-Head-of-Train
Second-Dragging-Equipment Near-Axle-1-4
Multiple-Dragging-Equipment Detected From-Axle-1-8 To-End-of-Train
Total Axles 1-0-0
Train Speed 4-5 M-P-H
Detector Out
```

At a single-track site having a combined number of Hotbox, High-Load, and Wide-Load alarms greater than the maximum alarm setting, the announcement is like this. For this example, the maximum number of alarms was set to three.

```
U P Detector
Milepost 3-2-1 point 4
First-High-Load Near Axle-1-2 From-Head-of-Train
First-Wide-Load East-Rail-Near Axle-1-4
First-Hotbox West-Rail Axle-2-5
Multiple-Hotbox High-Load and Wide-Load Detected From-Axle-2-8
To-End-of-Train
U P Detector
Milepost 3-2-1 point 4
First-High-Load Near Axle-1-2 From-Head-of-Train
First-Wide-Load East-Rail-Near Axle-1-4
First-Hotbox West-Rail Axle-2-5
Multiple-Hotbox High-Load and Wide-Load Detected From-Axle-2-8
To-End-of-Train
Total Axles 1-0-0
Train Speed 4-5 M-P-H
Detector Out
```

When Dragging Equipment, High Load, or Wide Load detector outputs are active as a train enters the site, “Detector Malfunction” messages appear in the post-train announcements, preceding any announcements for alarms associated with an axle. A separate message appears for each active alarm type. If both Wide-Load outputs are active as a train enters a site, only one “Wide-Load Detector Malfunction” message is announced.

For example, at a single-track site with the Dragging-Equipment detector active as the train arrives, the announcement is like this.

```
U P Detector
Milepost 3-2-1 point 4
Dragging Equipment Detector Malfunction
U P Detector
Milepost 3-2-1 point 4
Dragging Equipment Detector Malfunction
Total Axles 1-0-0
Train Speed 4-5 M-P-H
Detector Out
```

At a single-track site with the High-Load and one or both Wide-Load detectors active as the train arrives, the announcement is like this.

```
U P Detector
Milepost 3-2-1 point 4
High-Load Detector Malfunction
Wide-Load Detector Malfunction
U P Detector
Milepost 3-2-1 point 4
High-Load Detector Malfunction
Wide-Load Detector Malfunction
Total Axles 1-0-0
Train Speed 4-5 M-P-H
Detector Out
```

At a single-track site having three Hotbox alarms, and with the Dragging-Equipment, High-Load, and one or both Wide-Load detectors active as the train arrives, the announcement is like this.

```
U P Detector
Milepost 3-2-1 point 4
Dragging Equipment Detector Malfunction
High-Load Detector Malfunction
Wide-Load Detector Malfunction
First-Hotbox East-Rail Axle-1-2 From-Head-of-Train
Second-Hotbox West-Rail Axle-1-4
Third-Hotbox East-Rail Axle-1-6
U P Detector
Milepost 3-2-1 point 4
Dragging Equipment Detector Malfunction
High-Load Detector Malfunction
Wide-Load Detector Malfunction
First-Hotbox East-Rail Axle-1-2 From-Head-of-Train
Second-Hotbox West-Rail Axle-1-4
Third-Hotbox East-Rail Axle-1-6
Total Axles 1-0-0
Train Speed 4-5 M-P-H
Detector Out
```

When a catastrophic transducer failure occurs in conjunction with an auxiliary alarm, alarm announcements omit the alarm sequence numbers (that is, “first,” “second,” ... “ninth”), the axle numbers, and the phrase “From Head Of Train.” If announcing a “Multiple ... Detected From Axle ... To End of Train” message, “From Axle ... To End of Train” does not announce.

For example, at a single-track site with a malfunctioning TO1 transducer, an active Dragging Equipment output within the first three recorded axles, and a Hotbox alarm, the announcement is like this.

```
U P Detector
Milepost 3-2-1 point 4
Dragging Equipment Detected
Hotbox Detected East-Rail
U P Detector
Milepost 3-2-1 point 4
Dragging Equipment Detected
Hotbox Detected East-Rail
Total Axles 1-0-0
Train Speed 4-5 M-P-H
Detector Out
```

At a single-track site with a malfunctioning TO2 transducer, an active High-Load output within the first three recorded axles, a Wide-Load alarm, and a Hot Wheel alarm, the announcement is like this.

```
U P Detector
Milepost 3-2-1 point 4
High-Load Detected
Wide-Load Detected East-Rail
Hot Wheel Alarm
U P Detector
Milepost 3-2-1 point 4
High-Load Detected
Wide-Load Detected East-Rail
Hot Wheel Alarm
Total Axles 1-0-0
Train Speed 4-5 M-P-H
Detector Out
```

If the system's milepost setting is "0000.0," the firmware eliminates both the word "milepost" and the milepost number from the message. The rest of the message announces as shown above.

The **Clearance Mode** option on the Equipment Settings (Advanced) submenu lets you pick how you want a clearance alarm to be announced. Select Multiplexed when a single tripwire is used for both high-load and wide-load detection (this single wire should be connected to high-load input). Select Separate when each high-load and wide-load detector has its own detection hardware. All of the real-time messages shown above correspond to a site configured for a Clearance Mode of **Separate**. At a site configured for a Clearance Mode of **Multiplexed**, the announcement is like this.

```
( tone )
Defect Detected
High-Wide Near-Axle-1-2
```

In the next example, each high-load and wide-load detector is wired individually to its input. The Clearance Mode option was set to **Separate**. And, one High-Load alarm is the only Exception Alarm that was encountered at this single-track site.

```
U P Detector
Milepost 3-2-1 point 4
First-High-Load Near Axle-7-5 From-Head-of-Train
U P Detector
Milepost 3-2-1 point 4
First-High-Load Near Axle-7-5 From-Head-of-Train
Total Axles 1-0-0
Train Speed 4-5 M-P-H
Detector Out
```

In the next example, a single tripwire is used for both high load and wide load detection. The Clearance Mode option was set to **Multiplexed**. And, one High-Load alarm is the only Exception Alarm that was encountered at this single-track site.

```
U P Detector
Milepost 3-2-1 point 4
First-High-Wide Near Axle-7-5 From-Head-of-Train
U P Detector
Milepost 3-2-1 point 4
First-High-Wide Near Axle-7-5 From-Head-of-Train
Total Axles 1-0-0
Train Speed 4-5 M-P-H
Detector Out
```

7.4 Rebroadcasting Post-Train Messages

Following train passage, recorded post-train announcements are available for rebroadcast until the time period defined by the **Rebroadcast Time Limit option** expires. Recorded messages are available indefinitely if this value is zero.

When rebroadcasting a recorded post-train announcement, the format used is:

```
Rebroadcast
(train messages) [ancillary messages]
Rebroadcast
Detector Out
```

For example, if the **Num Repeat No Defects** option on the Messages Settings (Advanced) submenu is set to 2, the **EOT Repeat Delay** option (on the same menu) is set to 3 seconds, and neither an Exception Alarm nor an Integrity Failure is detected on the last train, the format of the rebroadcast message is:

```
Rebroadcast
U P Detector Milepost (mile) [track indicator] No Defects
  (3-second pause)
U P Detector Milepost (mile) [track indicator] No Defects [ancillary
messages]
Rebroadcast
Detector Out
```

When no Exception Alarms are detected, but an Integrity Failure is detected on the last train, the format of the rebroadcast message is:

```
Rebroadcast
U P Detector Milepost (mile) [track indicator] Integrity Failure
U P Detector Milepost (mile) [track indicator] Integrity Failure
[ancillary messages]
Rebroadcast
Detector Out
```

When one or more Exception Alarms are detected on the last train, the format of the rebroadcast message is:

```
Rebroadcast
U P Detector Milepost (mile) [track indicator] [alarm announcements]
U P Detector Milepost (mile) [track indicator] [alarm announcements]
[ancillary messages]
Rebroadcast
Detector Out
```

When no recorded post-train announcement exists, the system announces a default message. The format of this message is:

```
Rebroadcast
U P Detector Milepost (mile) [track indicator]
No Rebroadcast
Detector Out
```

Only a train's post-train announcements are recorded. Arrival messages and real-time messages are ignored. Any changes the customer makes to the ancillary announcement options or any dynamic change of the Talker Mode has no effect on the rebroadcast message. It plays whatever the last passing train heard, regardless of the current system settings.

8.0 Scheduled Maintenance

This section lists the items that STC recommends be done during scheduled maintenance.

An up-and-running SmartScanNG² system needs to be visited from time to time to do scheduled maintenance. The frequency of these visits is up to the customer. STC recommends visits every 30 to 90 days. Maintenance requirements change with environmental conditions. For example, if the system is installed in a damp or dusty environment, it may be necessary to visit the location more frequently to clean the optics. The optical system is the item most likely to need periodic maintenance. If moisture or dust isn't a problem, you may not need to do scheduled maintenance more often than every 90 days.

What is done during a maintenance visit is up to the customer. However, STC does have some recommendations. For normal scheduled maintenance, STC recommends these steps.

- 1 Be sure that you have on hand a 50-foot (15-meter) or longer tape measure, a #2 Phillips head screwdriver, a small slotted screwdriver, a 9/16-inch torque wrench, a laptop computer, a multimeter, and the alignment fixture.
- 2 At trackside, check track conditions on all tracks.
- 3 If any track is pumping (vertical displacement of the rails) or running (lateral displacement of the rails) more than 2 inches (5 centimeters), have it repaired before proceeding.
- 4 At trackside, check for damaged transducers, damaged transducer cables, and other damaged components.
- 5 If you find any damaged components, repair or replace them before proceeding.
STC transducers don't require a lot of care and attention. Once installed correctly, you don't need to remove them from the rail for cleaning or readjustment.
- 6 At trackside, check all transducer-mounting bolts on all tracks to make sure that all transducers are snug against the rail.

Four bolts are needed to hold the transducer in place. Two square-head bolts go through the mounting plate and transducer body. Two hex-head bolts go through the mounting plate and rail. If any of these bolts are sheared or missing, they must be replaced with the correct replacement bolt. Also, if any washers or nuts are missing, they must be replaced.

- 7 If all transducers aren't snug against the rail, fix this problem before proceeding.
Each installed transducer body should be 1-9/16 inches (3.97 centimeters) below the top of the rail and parallel to it. You can meet this requirement by using the transducer height bracket on the bottom of the alignment fixture.

- 8 Place the alignment fixture across both rails, centered over each transducer in turn.
- 9 Check if each transducer body just touches the bracket.

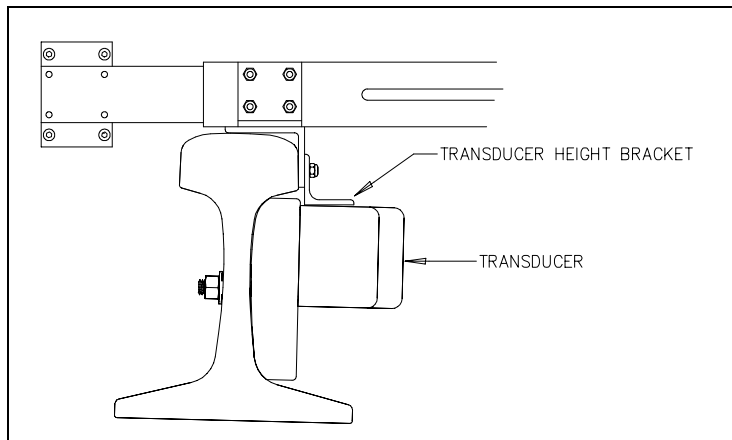

The fixture should be snug against the top and gauge of both rails. This may be impossible if the transducer body is less than 1-9/16 inches (3.97 centimeters) below the top of the rail or if the transducer body isn't parallel to the top of the rail.

- 10 If a transducer body doesn't just touch the bracket:
 - a Loosen the nuts holding the transducer body to its mounting plate.
 - b By sliding it up and down, adjust the transducer body to the proper height.
 - c Tighten each hex nut with a 9/16-inch torque wrench to a **torque of 12 to 15 foot-pounds (16.3 to 20.3 newton-meters)**.

Don't exceed a torque of 15 foot-pounds (20.3 newton-meters). Doing so can weaken or break a bolt, requiring the bolt to be replaced.

- 11 At the trackside, check all scanner-mounting bolts on all tracks.
- 12 If all scanner mounts aren't snug against the gauge side of the rail, fix this problem before proceeding.
- 13 From under all scanners, remove ballast that could damage the scanner during train passage.
- 14 Remove all obstructions to the scan path of each scanner.
- 15 If the wayside enclosure isn't attached to a properly installed outside grounding system, fix this problem before proceeding.
- 16 At all outlets inside the wayside enclosure, check if the AC power is stable and at least 110 volts at 20 amperes.
- 17 If the AC power isn't stable or if it isn't at least 110 volts at 20 amperes, fix this problem before proceeding.
- 18 If not all outlets inside the wayside enclosure are grounded properly, fix this problem before proceeding.

- 19 If the battery is dead, damaged, or emitting a strong sulfurous odor, replace it before proceeding.

WARNING

In operation, batteries generate and release flammable hydrogen gas, which, if ignited by a burning cigarette, naked flame, or spark, may cause a battery explosion with a dispersion of casing fragments and corrosive liquid electrolytes. So, carefully follow the manufacturer's instructions for installation and service. Keep all sources of gas ignition away from the batteries and do not allow metallic articles to contact the negative and positive terminals of a battery at the same time.

WARNING

A damaged or aged battery, in combination with the connected battery charger, can pose a severe health threat. The battery can produce hydrogen sulfide gas, which is characterized by its unique "rotten egg" smell. So, when a strong sulfurous odor is detected, remove power to the battery charger and check the battery for excessive heating. Do not inhale the fumes.

- 20 If the battery charger hasn't been properly grounded, fix this problem before proceeding.
- 21 If the SmartScanNG² enclosure hasn't been properly grounded, fix this problem before proceeding.
- There are vents on the top, bottom, and sides of the charger. Blocking any of these vents could result in damage to the charger or battery.
- 22 Remove anything that is blocking the vents on the battery charger.
- One end of the battery temperature probe cable has a three-pin plug, which plugs into a receptacle on the front of the battery charger. The other end, which has a temperature sensor sealed in it, should be attached to the negative battery post. If the battery temperature probe is defective or not installed, the red defective temperature probe LED is lit.
- 23 On the front of the battery charger, if the red defective-temperature-probe LED is lit, fix the underlying problem before proceeding.
- 24 Switch the multimeter to the DC volts scale.
- The **equipment side** of the fuse block is directly wired to the SmartScanNG² enclosure. The **battery side** of the fuse block is wired to the battery via the distribution block.
- 25 Touch the leads from the multimeter to the terminals on the equipment side of the fuse block.

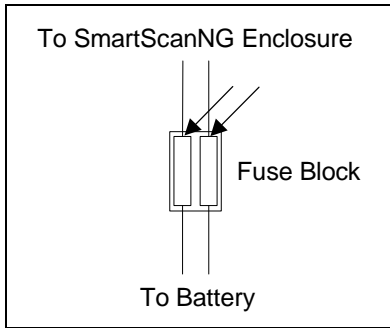

- 26** If the voltage (on the equipment side of the fuse block) is 12.3-14 VDC (for a 12V system) or 22-28 VDC (for a 24V system), go to step **30**.
- 27** If the voltage (on the equipment side of the fuse block) is 0 VDC:
- Touch the leads to the terminals on the battery side of the fuse block.
 - If the voltage (on the battery side of the fuse block) is greater than 0 VDC, replace each fuse in the fuse block with a BAF-25 (25-amp 250-volt) fast-acting fuse and return to step **25**.
 - If the voltage (on the battery side of the fuse block) is 0 VDC, fix any wiring problems between the fuse block, the distribution block, the battery, and the charger.
 - Return to step **25**.
- 28** If the voltage is less than 12.3 VDC (for a 12V system) or 22.0 VDC (for a 24V system):
- On the battery charger, check the input voltage switch for the proper setting.

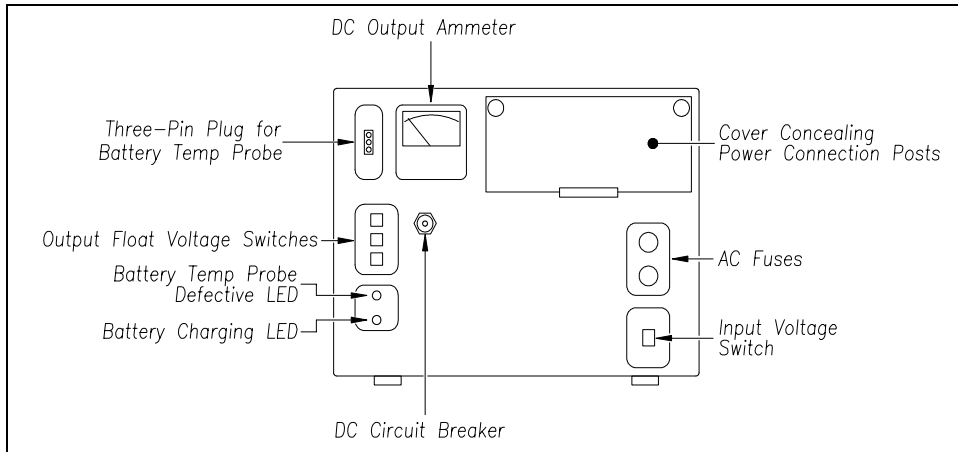

The input voltage switch can be set to 115 VAC or 230 VAC. Use 115 for input voltages between 108 and 128. Use 230 for input voltages between 216 and 256.

- On the battery charger, check the output float voltage switches.
- The factory default is **14.00 VDC** for a 12-volt system and **28.0 VDC** for a 24-volt system.

To reset the switches, use a small slotted screwdriver to turn each switch to the desired number.

- Open the small door cover on the top-right corner of the front of the charger.

Do not touch the uninsulated parts of the wires or the charger's binding posts. Doing so could result in sparks, burns, or electric shock.

- e** Check that all binding post nuts are tight and that all wiring is correct.
 - f** On the battery charger, check the AC fuses to see if either is blown.
 - g** If blown, replace with 4-amp 250-volt fast-acting fuses.
 - h** On the battery charger, check the DC circuit breaker to see if it is open (tripped).
When closed, about 0.09 inch (0.23 centimeters) of the breaker's button is seen.
When open, the button is popped out, showing about 0.25 inch (0.64 centimeters).
 - i** If open (tripped), push the breaker's button in to reset the DC circuit breaker.
 - j** Check to see if the battery charger is plugged in.
 - k** If the battery charger isn't plugged in, plug it in.
 - l** Check the battery-charging LED.
If the battery is charging properly, the yellow battery-charging LED is lit solid. If one or more of the output float voltage switches are set between numbers, the yellow battery-charging LED flashes.
 - m** If the yellow battery-charging LED is not lit, call STC for help in fixing this problem.
 - n** If the yellow battery-charging LED is lit solid, monitor the voltage for ten minutes.
If the voltage is gradually increasing, the battery is probably charging. After the battery has been charged for five hours, the battery voltage should be very near the float voltage setting. If the voltage isn't gradually increasing, the battery is probably not charging. This may indicate that the battery is defective and should be replaced.
- 29** If the voltage is greater than **28 VDC** (24-volt system) or **14 VDC** (12-volt system):
- a** Check the output float voltage switches on the center-left edge of the battery charger. They should be set no higher than factory defaults.
 - b** Be sure that each switch is set on a number and not between numbers.
 - c** To reset the switches, use a small slotted screwdriver to turn each switch to the desired number.

30 On the display panel, look at the COP-A and COP-B LEDs.

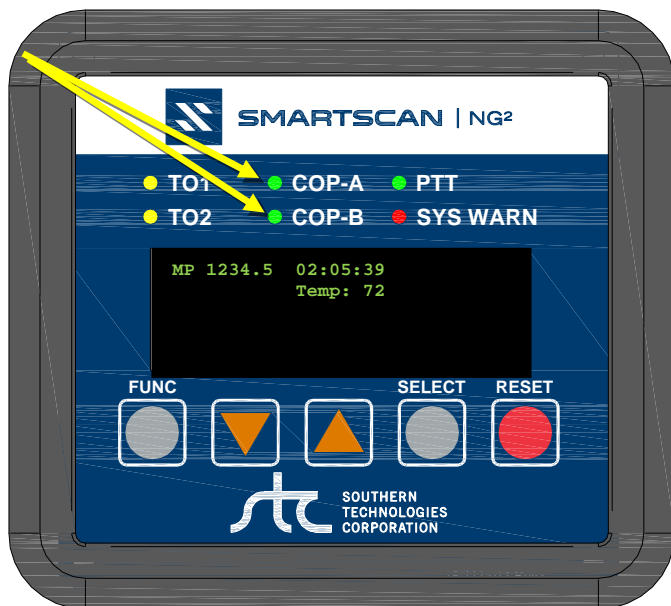

The COP LEDs indicate the condition of the CPUs. If both CPUs are running their programs correctly, their LEDs blink on and off. If a program isn't operating as expected, the LED for the affected CPU is lit solid or isn't lit at all.

- 31 If either or both of the **COP LEDs** are lit solid or aren't lit at all, call STC for help in fixing this problem.
- 32 On the display panel, look at the **SYS WARN** LED. If a system warning has been flagged, the SYS WARN LED will be lit, and the Check System Health message will be displayed on the bottom text line of the home screen. The Sys. Health Menu provides the status for various system health checks.
- 33 To see if the system is being activated by the gating transducers:
- a Produce a Train Detail Report for the last train.
Section 6.0 - Producing Reports tells how to produce this report.
 - b On the Train Detail report, check under the System Alarms section of the report for the words "No Approach Track."

The No Approach Track alarm indicates that the track circuit (or the advance transducers) failed to signal the presence of a train and that the SmartScanNG² system started from the train passing over the gating transducers.
 - c If the words "No Approach Track" don't appear, go to step 37.
- 34 If your system uses advance transducers, go to step 36.
- 35 If your system uses a track circuit, recalibrate the presence detector board:
- a) From the center of the gating transducers, measure the distance you want the track circuit to pick up the presence of a train.
 - b) The distance must be at least 50' (15.24 m) and no more than 150' (45.7 m).

- c) At the point just measured, place a 0.06Ω shunt across both rails. The track must be shunted before the calibration switch is pressed.
- d) Press and HOLD the Calibration Switch until the SOTC LED starts blinking. Release the switch, and the LED will stop blinking. The ZEPIC III will automatically begin the calibration process. NOTE: The track shunt MUST remain in place during the calibration process.

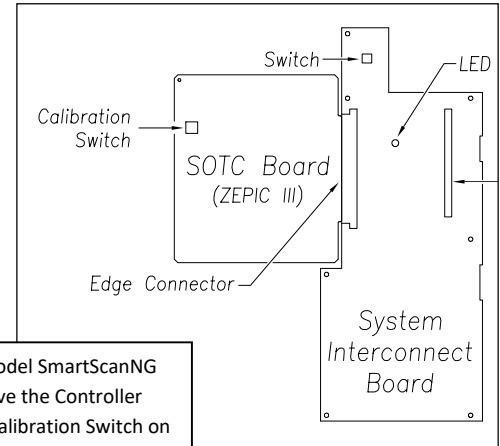

NOTE: For the older model SmartScanNG Chassis you must remove the Controller Module to access the Calibration Switch on the Zepic III board.

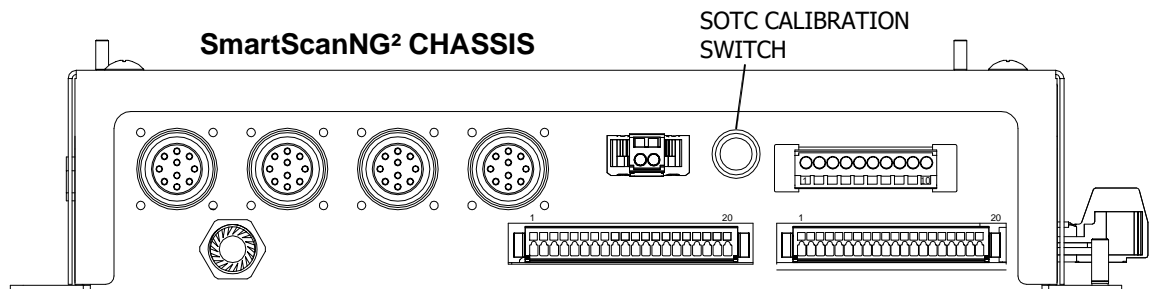

- e) The relay drive will pick up (SOTC LED on) when the unit has successfully calibrated. This process can take up to 45 seconds to complete.

Verification

- a) After calibration, lift the shunt, and the relay drive should drop (LED off). Replace the shunt, and the relay drive will pick up (LED on).
- b) Move the shunt approximately 10' farther out from the calibration point. The relay drive should not pick up (LED stays off). If this test fails, perform Short Track Calibration (detailed below).
- c) The PD8-Plus is now operating properly and will activate at an equal distance on either side of the track feed point.
- d) After trackside calibration procedures have been successfully completed, place a temporary shunt across the track wires inside the bungalow and verify that the signal system goes to stop. Once verified, remove the temporary shunt.

IMPORTANT: To ensure an accurate activation point, always place the shunt BEFORE pressing the Calibration Switch.

If the PD8-Plus cannot achieve calibration, it will blink the relay drive LED three (3) times in rapid succession, indicating a calibration error. The unit will continuously repeat the calibration procedure (there is no need to press the Calibration Switch), allowing you to troubleshoot the track circuit, wiring, and battery. Once the issue has been corrected, repeat the calibration procedure.

Both the ZEPIC III and Zepic PD8-Plus have a two-wire track circuit and will activate an equal distance on both sides of the track feed point.

PD8-Plus Short-Track Circuit Calibration

- a) The system may fail the 10 ft calibration verification step noted above if the installation is using 26KHz and the desired CAL point is ~30ft from the feed points (Short track circuit), and the bungalow is near the track (short track wires).
- b) If this is the case, reconfigure the PD8-Plus to a lower frequency that is compatible with other equipment that may be on the track. In general, changing from 26KHz to 20KHz or 17.5KHz should solve the short-track circuit calibration issue.
- c) Once the module has been reconfigured for the new operating frequency, repeat the normal calibration procedure detailed above.

PD8-Plus Troubleshooting and Application Notes

- a) If the unit will not calibrate, watch the relay drive LED for approx 45 seconds. If it blinks, this means the PD8-Plus has turned its receiver gain to the maximum setting and cannot see the track shunt. Look for open circuits between the PD8-Plus and the shunt on the track. I.e., track wires, bond wires, etc.
- b) The PD8-Plus will look equally in both directions. If one side of the circuit has insulated joints, the PD8-Plus will operate. However, the activation distance will not be the same. In general, track circuit equipment cannot see past insulated joints.
- c) Audio overlay systems like the PD8-Plus will not work with wideband shunts in their track circuit range.
- d) If the relay drive is stuck ON, look for short circuits between the PD8-Plus and the desired pick point.
- e) The greater the distance between the PD8-Plus and track connections, the greater the effects ballast will have on the PD8-Plus performance.
- f) Presence output is a dry contact configuration Form –C dry contact, 225mA max current. (N.O. contact with no train presence)
- g) In good track ballast conditions, a PD8-Plus circuit can travel up to 500 ft in each direction. Rotating operating frequencies to avoid interference with other equipment is recommended.
- h) The higher the operating frequency, the shorter the track circuit.

36 If your system uses advance transducers:

You will next verify that each advance transducer is functional.

- a** Using a metal wrench, stroke the top of one of the advance transducers.
The scanner shutters should open completely for 10 seconds.
- b** On one of the bearing scanners, check to see if the shutter opens.
- c** If the shutter didn't open, fix this problem before proceeding.
- d** Wait until the detector times out and closes the shutters. Using a metal wrench, stroke the top of the other advance transducer.
The scanner shutters should open completely for 10 seconds.
- e** On one of the bearing scanners, check to see if the shutter opens.
- f** If the shutter didn't open, fix this problem before proceeding.

37 Produce a Train Summary report.

Section 6.0 – Producing Reports tells how to produce this report.

The Train Summary report lists all trains currently stored in the Trains directory. A line of information is shown for each train entry. The report is divided into a header section and a detail section. The header section contains general information about the site. The detail section contains summary information on each train that passed the site.

38 On the Train Summary report, check the Axles column.

Axle count should be an even number. Odd-numbered axle counts are possible indications of gating transducer problems.

39 If there is an odd axle count and if train speed was always above 7 mph, go to step **41**.

If at any time during train passage the train speed was less than or equal to 7 mph (11.3 kph), gating transducer problems probably don't exist. If the train speed was always above 7 mph, gating transducer problems probably do exist.

The Very Slow Train alarm indicates that, at some point during train passage, four consecutive axles crossed the gating transducers at a speed of 7 mph (11.3 kph) or less. This alarm appears on a Train Detail report.

If there are many slow trains (that is, many trains traveling less than 7 mph) at this site, it may be necessary to relocate the scanners and other track hardware to a better location. Decisions to do this should be made in consultation with STC. Relocating a site is beyond the scope of this document.

40 If there is an even axle count and the values under "Axles," "T01," and "TO2" are the same, go to step **45**.

If things are working correctly, all three values for a given train should be equal. You'll do the next step only if things aren't working correctly.

41 Determine which gating transducer is recording incorrect information.

Determine which gating transducer is recording incorrect axle counts and whether it is not counting all axles or counting extra ones. You may not be able to do this by just looking at the values under the Axles, TO1, and TO2 columns of the Train Summary report. Sometimes, a transducer problem causes the number in the Axles column to be incorrect. Therefore, the true axle count may have to be determined from an alternate source, such as the next detector system that encounters the train with the transducer-count imbalance.

After you determine which gating transducer is miscounting, you'll need to change a jumper setting on the Interface board. If TO1 is the problem, you'll change the setting for J201. If TO2 is the problem, you'll change the setting for J202. If both TO1 and TO2 have a problem, both jumpers will need to be changed.

Changes to the jumpers should be made only after all external conditions that cause transducer miscounts have been corrected. Some of these external conditions are improperly installed transducers, loose transducer bolts, incorrect transducer heights, damaged transducers, damaged transducer cables, and loose wiring connections. You should have already checked for and corrected these external conditions in steps **4** through **10** above. If you think the corrections you made in those steps fixes gating transducer miscounting, you can skip some of the steps below.

The process of adjusting the transducer loading is trial and error. Generally, if you have too many transducer counts, lower the loading resistance to make the transducer less sensitive. Likewise, too few counts suggest that the transducer is not sensitive enough, so you would select a loading value with more resistance.

42 If you corrected all external conditions that negatively affect gating transducers and you think this fixes gating transducer miscounting, go to step **45**.

43 If the selected gating transducer appears to be missing axles (that is, the transducer that is showing a number of hits less than the true axle count):

- a** Toggle off the DC power switch on the right edge of the SmartScanNG² enclosure.

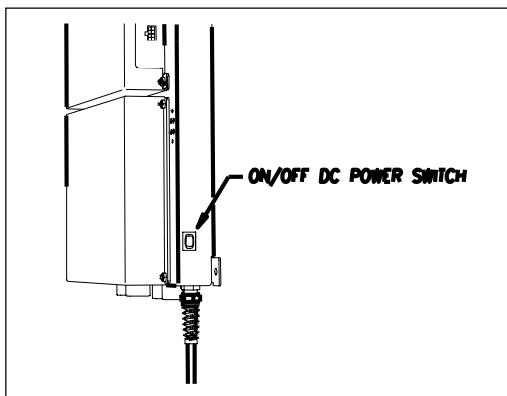

- b** Remove the six nuts and three screws holding the cover over the Interface board.

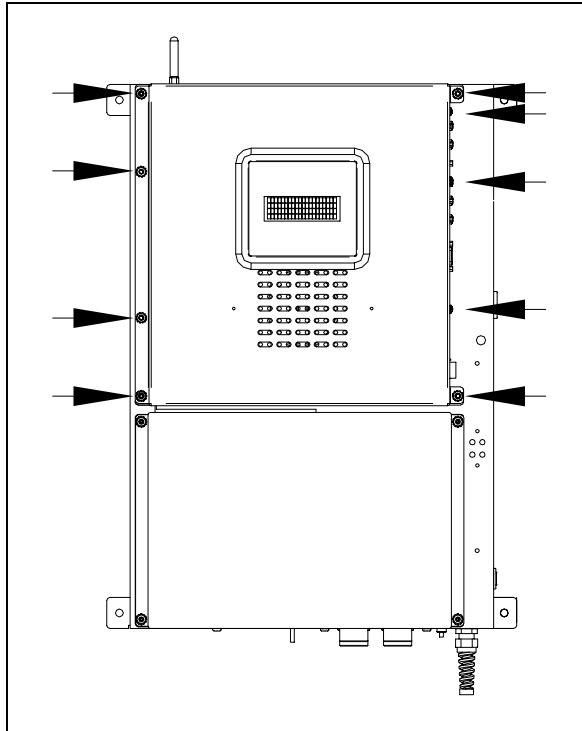

The Interface board is now visible.

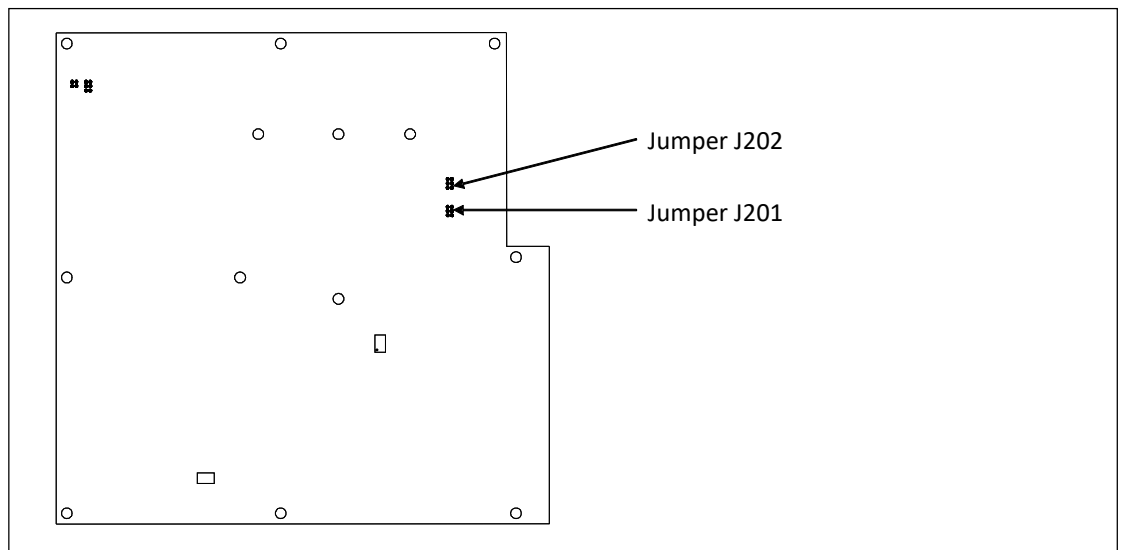

- c** To prevent the base assembly from falling, replace two of the nuts onto the top two mounting studs on the SmartScanNG² enclosure.
- d** Store the removed cover, three screws, and remaining four nuts in a safe place until you replace them.

- e The table below lists the highest, middle, and lowest sensitivity for transducer loading. The highest is the most sensitive. The jumper's top position is the one closest to the external speaker.

J201 or J202 Jumper Position	Sensitivity Level
Top	Lowest Sensitivity
Center	Middle Sensitivity
Bottom	Highest Sensitivity

- f If TO1 is the selected gating transducer and the J201 jumper is currently on the lowest sensitivity position, move it to the middle sensitivity position.
 - g If TO1 is the selected gating transducer and the J201 jumper is currently on the middle sensitivity position, move it to the highest sensitivity position.
 - h If TO1 is the selected gating transducer and the J201 jumper is currently on the highest sensitivity position, call STC for help in fixing this problem.
 - i If TO2 is the selected gating transducer and the J202 jumper is currently on the lowest sensitivity position, move it to the middle sensitivity position.
 - j If TO2 is the selected gating transducer and the J202 jumper is currently on the middle sensitivity position, move it to the highest sensitivity position.
 - k If TO2 is the selected gating transducer and the J202 jumper is currently on the highest sensitivity position, call STC for help in fixing this problem.
 - l Remove the two nuts holding the base assembly to the SmartScanNG² enclosure.
 - m Using the saved six nuts and three screws, reattach the cover over the Interface board.
 - n Toggle on the DC power switch on the right edge of the SmartScanNG² enclosure.
- 44 If the selected gating transducer appears to be counting extra axles (that is, the transducer that is showing a number of hits more than the true axle count):
- a Toggle off the DC power switch on the right edge of the SmartScanNG² enclosure.

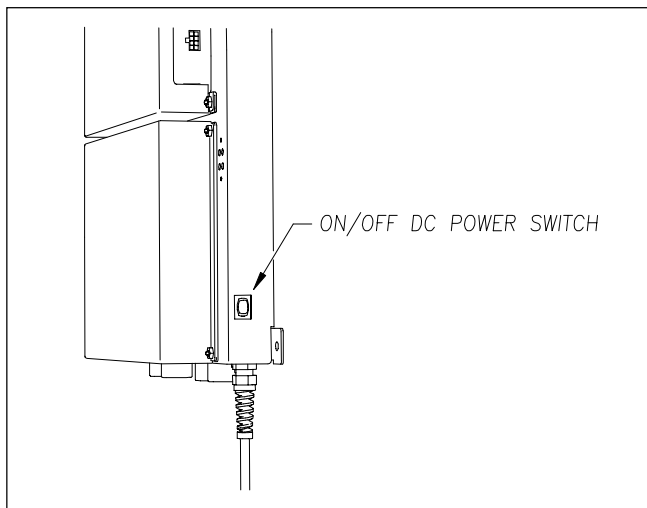

- b Remove the six nuts and three screws holding the cover over the Interface board.

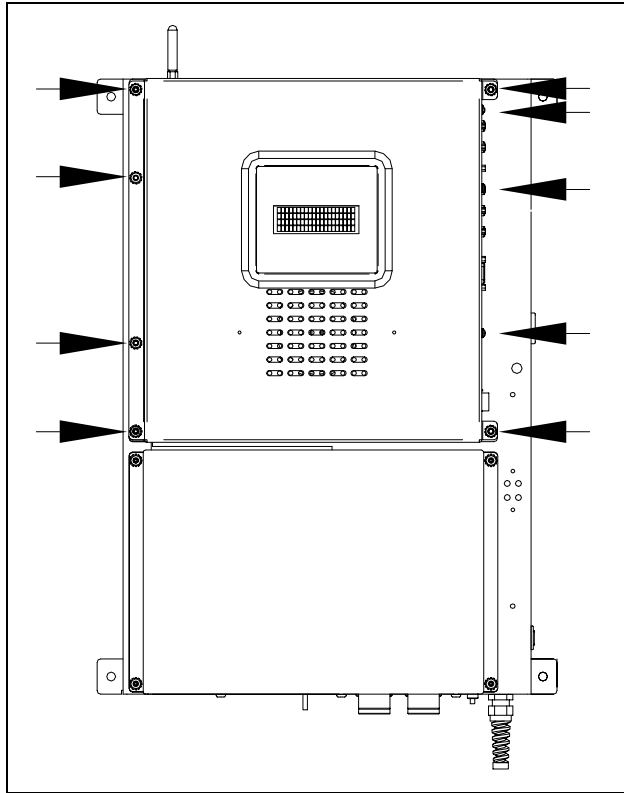

The Interface board is now visible.

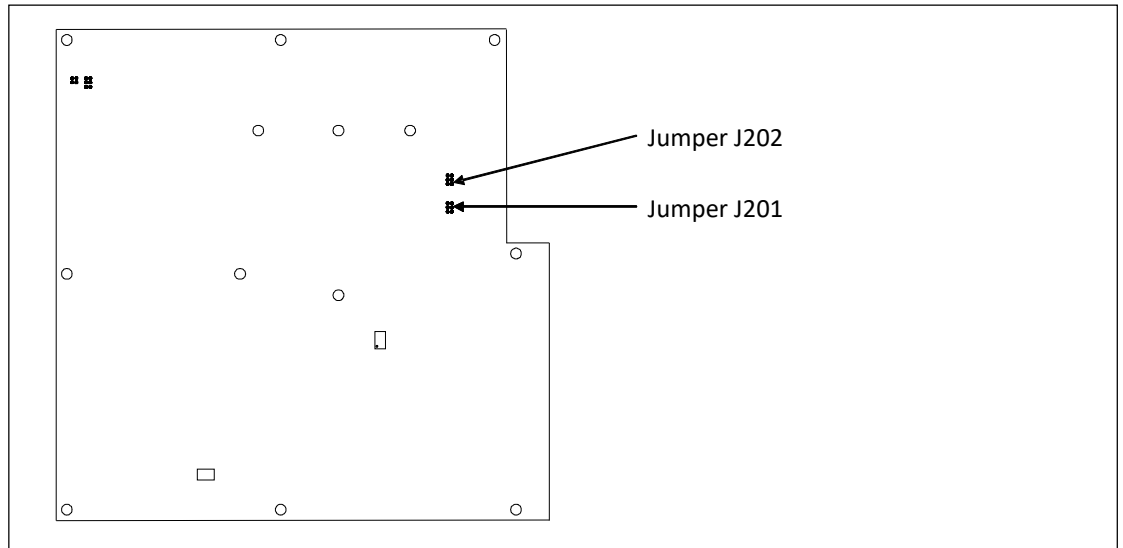

- c** To prevent the base assembly from falling, replace two of the just removed nuts onto the top two mounting studs on the SmartScanNG² enclosure.
- d** Store the removed cover, three screws, and the remaining four nuts in a safe place until you replace them.

- e The table below lists the highest, middle, and lowest sensitivity for transducer loading. The highest is the most sensitive. The jumper's top position is the one closest to the external speaker.

J201 or J202 Jumper Position	Sensitivity Level
Top	Lowest Sensitivity
Center	Middle Sensitivity
Bottom	Highest Sensitivity

- f If TO1 is the selected gating transducer and the J201 jumper is currently on the highest sensitivity position, move it to the middle sensitivity position.
 - g If TO1 is the selected gating transducer and the J201 jumper is currently on the middle sensitivity position, move it to the lowest sensitivity position.
 - h If TO1 is the selected gating transducer and the J201 jumper is currently on the lowest sensitivity position, call STC for help in fixing this problem.
 - i If TO2 is the selected gating transducer and the J202 jumper is currently on the highest sensitivity position, move it to the middle sensitivity position.
 - j If TO2 is the selected gating transducer and the J202 jumper is currently on the middle sensitivity position, move it to the lowest sensitivity position.
 - k If TO2 is the selected gating transducer and the J202 jumper is currently on the lowest sensitivity position, call STC for help in fixing this problem.
 - l Remove the two nuts holding the base assembly to the SmartScanNG² enclosure.
 - m Using the saved six nuts and three screws, reattach the cover over the Interface board.
 - n Toggle on the DC power switch on the right edge of the SmartScanNG² enclosure.
- 45 To use the serial interface to open the scanner shutters:
- a Using the serial interface, display the Main menu.

Section 4.0 - Serial Interface tells how to display the Main menu

- b Select the System Functions Menu

```

System Functions Menu
-----
[A] - Radio Test
[B] - Vocabulary Test
[C] - Radio Inhibit
[D] - Start Manual Train
[E] - 1KHz Test Tone
[F] - Auto-Calibration
      .
      .
      .

```

- c To open the shutters, select the Auto-Calibration option.

The protective shutters in all scanners should open and stay open for three minutes. This might not be enough time to check and clean the shutters and optics. If that isn't enough time, select this option again.

- 46 In each scanner, check if its shutter is opened.
- 47 If any shutter didn't open, fix this problem before proceeding.
- 48 In each scanner, check for dirty optics.
- 49 If dirty, clean the scanner optics with the supplied lens cleaning kit.

Do not use solvents, ammonia-based cleaning solutions, or isopropyl alcohol on the optics. Use clean water or a mild solution of dishwashing liquid. After the liquid on the optics dries, lightly wipe the optics with a clean, dry chamois patch.

- 50 If the date and time displayed on the top of the System Functions menu are incorrect, fix them before proceeding.

Section 4.0 - Serial Interface tells how to change the date and time.

- 51 To check the operation of the radio:

- a From the System Functions menu, select Radio Test.

During a radio test, the SmartScanNG² system outputs phrases through the speaker and through the radio. Alternatively, you can output a 1kHz test tone instead of phrases. To do this, you would select the 1KHz Test Tone option.

- b While listening to the message or tone, look at the display panel.

The PTT LED should be lit.

If this LED isn't lit, the system's ability to send a message or tone to the radio might be inhibited. This can happen when one uses the Radio Inhibit option on the System Functions menu. If the radio is inhibited, the results of this check are invalid.

- c If the PTT LED isn't lit, and the radio isn't inhibited, call STC for help in fixing this problem.

- 52 To check the integrity of the speech data:

- a Be sure that the speaker has its volume set to an audible level.

- b Using the serial interface, display the Main menu.

Section 4.0 - Serial Interface tells how to display the Main menu.

- c Select the System Functions menu.

```

Main Menu - Comm
          .
          .
[K] - Event log
[L] - System Functions Menu
[M] - Replay train
[N] - Security Menu
[X] - Exit

```

- d From the System Functions menu, select Vocabulary Test

```
System Functions Menu
-----
[A] - Radio Test
[B] - Vocabulary Test
[C] - Radio Inhibit
[D] - Start Manual Train
      .
      .
      .
```

This message appears.

```
Vocabulary test started
```

If the system isn't currently making any other voice announcements, it begins the Vocabulary Test announcement. The SmartScanNG² system outputs phrases through the speaker but not through the radio.

- e If you hear nothing or speech that is too garbled to understand, call STC for help in fixing this problem.
- 53 To generate a test train to check the number of axles:
- a Quickly stroke the top of each gating transducer with a metal wrench, alternating between TO1 and TO2.
 - b Repeat step a nine more times, for a total of **ten** simulated axles.
 - c Wait for the system to time out and the shutters to close.
 - d Produce a Train Detail report for the last train.
Section 6.0 - Producing Reports tells how to produce this report.
 - e On the report, check that the number of axles agrees with the number of times that you stroked the gating transducers.
 - f On the report, if the number of axles doesn't agree with the number of times that you stroked the gating transducers, call STC for help in fixing this problem.

54 To generate a test train to check for hot bearings:

STC recommends that you use the calibrated heat source (2100-810NG) only when the outside (ambient) temperature is above 0°F (-18°C) and below 90°F (32°C). If you must use it at other times, do so only when the needle is centered on the front of the temperature meter. If the needle isn't stabilized within ± 2 degrees of the setpoint, the heat source isn't operating properly.

a Ready the calibrated heat source.

The heat source has reached operating temperature and stabilized when the temperature meter needle remains centered.

b With the power cord to the front of the scanner, place the calibrated heat source on the bearing scanner that is on the rail with the gating transducers.

c Quickly stroke the top of each gating transducer with a metal wrench, alternating between TO1 and TO2 for a total of **six** simulated axles.

You should hear the real-time defect message. No matter how many defects are found, the real-time defect message is only announced once.

d Wait for the system to time out, which normally takes about 10 seconds.

You should hear an end-of-train message with three Hotbox alarms. Per train, only the first three Hotbox alarms are ever announced.

e Listen to be sure that the Hotbox alarms are announced and that they are announced for the correct side.

If you do not hear anything, no alarm-level heat was recorded. No measurable heat from a bearing scanner may be due to loose connections, a scanner not being connected to the bottom of the SmartScanNG² enclosure, a defective shutter motor in the scanner, or a damaged scanner.

f If you do not hear any Hotbox alarms being announced, fix this problem before proceeding.

g If the Hotbox alarms are announced for the wrong side, switch the bearing scanner connections on the bottom of the SmartScanNG² enclosure.

h Repeat the test, this time placing the calibrated heat source on the bearing scanner on the opposite rail

i Verify the results as before.

If the results are correct, your system should function properly when scanning the bearings of real trains.

j Remove the calibrated heat source.

k Store the calibrated heat source and its cable in the wayside enclosure.

55 On the Train Summary report, check the column marked "Average."

For each train, the values in the two columns under this heading should be within four degrees of each other.

56 If the columns aren't within four degrees and if the scanner optics are clean, recalibrate and realign the scanner.

Appendix E & F - Calibration of Type II/Type III Scanners tells how to calibrate the scanners.

57 On the Train Summary report, check the last column of the report.

The last column shows the battery voltage at the time each train passed the site. It should show values between 13.0 and 14.5 volts (12V system) or between 25.0 and 28.0 volts (24V system). Values outside this range may be caused by:

- No AC power for an extended period
- Improperly adjusted float voltage
- Defective battery
- Blown fuses
- Defective battery charger

58 If the most recent value isn't within the normal range, investigate and fix any problems before proceeding.

59 If this is a double-track site, repeat steps **18** through **59** for the other track (that is, for the other SmartScanNG² system).

9.0 Customer Service

At STC, the customer is number one. STC is committed to products that work and customers that are satisfied. Nothing less is acceptable. This section tells how to get answers for questions, fixes for problems, and parts for spares.

9.1 Reaching STC

You can reach STC by mail, telephone, fax, and email. By mail, you can reach STC at:

Southern Technologies Corporation
6145 Preservation Drive
Chattanooga, Tennessee 37416-3638
USA

Mail and shipments are replied to as soon as possible, normally within one working day. Equipment repair usually takes longer.

By telephone, you can reach STC at 423-892-3029, Monday through Friday, from 8:00 a.m. until 5:00 p.m. Eastern time. After business hours, a machine answers the calls. These calls are returned promptly the next business day. By fax, you can reach STC at 423-499-0045. The fax machine can receive faxes at all times. Faxes are replied to as soon as possible, normally within one working day. By email, you can reach STC at stcemail@southern-tech.com. Email is replied to as soon as possible, normally within one working day.

9.2 Returning Equipment for Repair

Return any defective or malfunctioning equipment to STC for repair or replacement. You don't need a return authorization number. You don't even need to make a telephone call first. Just ship it directly to the **Repair Department** at the address above.

With the returned equipment, include:

- Complete address of where the equipment is to be returned.
- Name and telephone number of the person who should be contacted to answer questions about the equipment.
- A written explanation of the equipment defect or malfunction.
- Any reports or other data that would be helpful in diagnosing the problem.
- If out of warranty, credit card number (to be charged) with its expiration date.

9.3 Reporting Problems or Suggestions

If you have any problems, suggestions, or questions related to STC equipment, telephone the **Engineering Department** at the telephone number above. When calling, state the equipment you're calling about. Your call will then be directed to the right person.

9.4 Ordering Spare Parts

If you need any spare parts to support STC equipment, telephone or fax the **Sales Department** at the telephone numbers above.

When calling, state that you're calling to order parts. Your call will then be directed to the right person. When placing the order, reference the STC part numbers listed in this guide. However, if you don't have the part numbers, the sales staff can obtain them for you and provide you with current pricing and availability.

When emailing or faxing, include:

- Purchase Order Number for the order or credit card number (to be charged) with its expiration date.
- Complete address where the parts are to be shipped.
- Complete address where the invoice is to be mailed.
- Name and telephone number of the person who should be contacted to answer questions about the order.
- For each item ordered, part number, complete description, and quantity needed.

9.5 Checking on Shipments and Orders

If you need to check on the status of any shipment or order, telephone or fax the **Sales Department** at the telephone numbers above.

When calling, state that you're checking the status of a shipment or order. Your call will then be directed to the right person. Have your Purchase Order Number ready when you call. However, if you don't have the order number, the sales staff can locate your order number and provide you with the status of the shipment or order.

When emailing or faxing, include:

- Purchase Order Number for the shipment or order being checked.
- Name and telephone number of the person who should be contacted after the order status is checked.
- Your fax number, if available.

Appendix A

System Alarms

This appendix describes the conditions and events that the SmartScanNG² system flags as System Alarms. These alarms provide data about passing trains and system status. These alarms are listed under the System Alarms section of the Train Detail, and Exception Detail reports. **Section 6.0 - Producing Reports** tells how to produce these reports. Some System Alarms depend on Setup parameters. **Section 4.0 - Serial Interface** tells how to view or change the Setup parameters through the Serial Interface. **Section 5.0 Web User Interface** tells how to print reports and view or change Setup parameters through the web interface.

A.1 AC Power Off Alarm

The AC Power Off alarm indicates that AC power wasn't on when it was checked during the end-of-train processing. This alarm doesn't say anything about any lack of power during train passage.

A.2 Advance Turn-On Failure Alarm

The Advance Turn-On Failure alarm indicates that the system's presence detection hardware (that is, the track circuit or the advance transducers) didn't detect the arrival of the train at the site. Instead, the system started the train-scanning process when a gating transducer sensed the train.

The arrival speed of the train must be at least 10 mph (16 kph) to generate an Advance Turn-On Failure alarm.

NOTE: This alarm is suppressed if the Presence Hardware and the Advance Transducer setting are set to "No" in the Equipment Setup submenu.

A.3 AEI Subsystem Alarms

The **AEI Subsystem: No Tags Antenna-1** or **No Tags Antenna-2** alarm indicates that no AEI tags were read by that specific antenna.

The **AEI Subsystem: No Tags** alarm indicates that no AEI tags were read by either antenna. If you get the "AEI Subsystem: No Tags" string in the System Alarm section of the Train Detail report, you will not get either of "AEI Subsystem: No Tags Ant 0" or "AEI Subsystem: No Tags Ant 1" System Alarms.

The **AEI Subsystem: Not Responding** alarm indicates that there is no response when the NG² sends commands to the AEI reader.

A.4 Ambient Temperature Probe Unreliable Alarm

The Ambient Temperature Probe Unreliable alarm indicates that the temperature probe is giving unreliable readings.

A.5 Blind Pyro Alarm

The Blind Pyro alarm indicates that an object may have blocked a scanner for at least 30 axles during train passage. If 30 or more consecutive axles have a bearing temperature of less than 3°F (1.6°C) on one side and greater than 19°F (10°C) on the opposite side, the scanner on the 3°F side is declared as having a "blind" pyrometer.

There is a different Blind Pyro alarm for each rail. That is, there is a Blind North Pyro alarm and a Blind South Pyro alarm (or, depending on track direction, a Blind East Pyro alarm and a Blind West Pyro alarm).

A.6 Cold Rail Alarm

The Cold Rail alarm indicates that the temperatures of all bearings (of the train) on the designated rail were below a given temperature. When no bearing on a given rail generates a delta temperature reading greater than or equal to the temperature set by the **Cold Journal Temp option** on the Alarm Settings menu, the system generates a Cold Rail alarm.

There is a different Cold Rail alarm for each rail. That is, there is a Cold North Rail alarm and a Cold South Rail alarm (or, depending on track direction, a Cold East Rail alarm, and a Cold West Rail alarm).

The **maximum number** (per railside) of consecutive trains, having Cold Rail alarms, allowed before generating a Successive Cold Rails Exceeded alarm is set by the **Cold Journal Counter option** on the Alarm Settings menu. The Successive Cold Rails Exceeded alarm is covered in the next appendix.

A.7 Cold Resistor Alarm

A resistor is mounted to the inside of the bearing scanner's shutter. A voltage is applied to this resistor while the shutter is open, causing it to heat up. After a train has left a site and the shutters have closed, the temperature of the resistor is read by the scanner pyrometer. In this way, a check of the system's ability to read heat correctly is made. The Cold Resistor alarm indicates that the **minimum value** expected for the temperature of the resistor wasn't met. This minimum value is determined by the firmware and is dependent upon the time it takes a train to pass a site.

If the **minimum value** wasn't met, a second check compares the recorded resistor temperature against the limit that was established using the **Absolute option** on the Alarm Settings menu. (This alarm limit is an offset, in degrees Fahrenheit, above the ambient temperature.) If the recorded resistor temperature meets or exceeds the absolute -alarm limit, the firmware cancels any previously flagged Cold Resistor alarms.

There is a different Cold Resistor alarm for each rail. That is, there is a Cold North Resistor alarm and a Cold South Resistor alarm (or, depending on track direction, a Cold East Resistor alarm, and a Cold West Resistor alarm).

After a train has passed the site, a more accurate *required* resistor value will be calculated, taking into account the ambient temperature. This new value is then used to calculate a correction factor. The factor is the percentage difference between the *required* resistor value and the value that was actually read. For example, if the *required* resistor temperature is 180 and the actual resistor temperature is 135, the correction factor would be 25% ($1 - (135 / 180) = 0.25$).

If the correction factor is less than 26%, no Cold Resistor alarm is generated.

If Cold Resistor Alarm conditions are met, two additional checks will be performed. Either of these checks can generate a Cold Resistor alarm. For more information on these checks, see **A.18 Rail Resistor Test Overridden Alarm**.

The **maximum number** (per raiiside) of consecutive trains, having Cold Resistor alarms, allowed before generating a Successive Cold Resistors Exceeded alarm is set by the **Cold Resistor Counter option** on the Alarm Settings menu. **Successive Cold Resistors Exceeded** alarms are covered in the next appendix.

A.8 Cold Wheel Scanner Resistor Alarm

The Cold Wheel Scanner Resistor alarm represents the wheel scanner's equivalent of the bearing scanner's Cold Resistor alarm. Evaluation of Cold Wheel Scanner Resistor alarm mimics the same logic used in the evaluation of Cold Resistor alarms. In this way, the system confirms the scanner's ability to read alarm level heat. Just like Cold Resistor alarms, separate Cold Wheel Scanner Resistor alarms exist for each raiiside.

After a train has passed the site, a more accurate *required* resistor value will be calculated, taking into account the ambient temperature. This new value is then used to calculate a correction factor. The factor is the percentage difference between the *required* resistor value and the value that was actually read. For example, if the *required* resistor temperature is 180 and the actual resistor temperature is 135, the correction factor would be 25% ($1 - (135 / 180) = 0.25$).

If the correction factor is less than 26%, no Cold Wheel Scanner Resistor alarm is generated.

If Cold Resistor Alarm conditions are met, two additional checks will be performed. Either of these checks can generate a Cold Wheel Scanner Resistor alarm. For more information on these checks, see **A.24 Wheel Resistor Test Overridden Alarm**.

The **maximum number** (per raiiside) of consecutive trains, having Cold Wheel Scanner Resistor alarms, allowed before generating a Successive Cold Wheel Resistors Exceeded alarm is set by the **Cold Resistor Counter option** on the Alarm Settings menu. **Successive Cold Wheel Resistors Exceeded** alarms are covered in the next appendix.

A.9 Efficiency Test Panel in Use Alarm

The Efficiency Test Panel in Use alarm indicates that someone used the Efficiency Test panel to generate a train alarm.

A.10 Equal Heats Test Failed Alarm

The Equal Heats Test Failed alarm indicates lower-than-expected heat readings from one railside. The firmware uses the average temperatures for rail1 and rail2 and calculates a percentage difference between them, flagging an alarm if this difference exceeds a predetermined alarm limit. The percentage difference between the two average rail temperatures is calculated using the formula $(b-a)/a*100$, where the variable 'a' represents the lower average rail temperature, and the variable 'b' represents the higher average rail temperature. As an example, for recorded average rail temperatures of 40 and 60 degrees, the calculated percentage difference would be 50% ($60-40=20$, $20/40*100=50$). The alarm limit is 100% and isn't user-configurable.

The **maximum number** of consecutive trains, having Equal Heats Test Failed alarms, allowed before generating a Max Equal Heat Test Failures Exceeded alarm is set by the **Cold Journal Counter** option on the Alarm Limits submenu. Max Equal Heat Test Failures Exceeded alarms are covered in the next appendix.

A.11 Highrange Transducer Miscounts Alarm

The Highrange Transducer Miscounts alarm indicates that the transducer counts for TO1 and TO2 differ by seven or more. This calculation is made after each axle crosses both gating transducers.

The Highrange Transducer Miscounts alarm can be either a System Alarm or an Integrity Failure, depending on the presence of a Very Slow Train alarm. If a highrange transducer miscount occurs on a train that also contains a Very Slow Train alarm, the firmware treats the miscount condition as a System Alarm. This logic assumes that the train's slow rate of travel likely caused the transducer to miscount condition. If a Highrange Transducer Miscount occurs on a train that does not also contain a Very Slow Train alarm, the firmware treats the miscount condition as an Integrity Failure.

A.12 Integrity Failure Alarm

The Integrity Failure alarm indicates that the SmartScanNG² system determined that a condition exists that could prevent proper scanning of a train. In other words, this alarm indicates the existence of one or more conditions in which the integrity of the system and its ability to record train data accurately may be compromised. These unusual conditions, called Integrity Failures, may require train stoppage, later maintenance, or both. They are covered in the next appendix.

A.13 Low Battery Alarm

For 24 VDC Systems:

The **Low Battery alarm** indicates a float voltage of at least 18.0 volts but less than 22.0 volts on the standby batteries. (The **Dead Battery alarm** indicates a float voltage of less than 18.0 volts, on the standby batteries.)

For 12 VDC Systems:

The **Low Battery alarm** indicates a float voltage of at least 11.8 volts, but less than 12.6 volts, on the standby battery. (The **Dead Battery alarm** indicates a float voltage of less than 11.8 volts on the standby battery).

A.14 Midrange Transducer Miscounts Alarm

The Midrange Transducer Miscounts alarm indicates that the transducer counts for TO1 and TO2 differ by five or six. This calculation is made after each axle crosses both gating transducers.

The Midrange Transducer Miscounts alarm can be either a System Alarm or an Integrity Failure, depending on the presence of a Very Slow Train alarm. If a midrange transducer miscount occurs on a train that also contains a Very Slow Train alarm, the firmware treats the miscount condition as a System Alarm. This logic assumes that the train's slow rate of travel likely caused the transducer miscount condition. If a midrange transducer miscount occurs on a train that does not also contain a Very Slow Train alarm, the firmware treats the miscount condition as an Integrity Failure.

A.15 Presence Detected On Adjacent Track Alarm

This alarm indicates that train presence was detected on an adjacent track. Both tracks must have AEI enabled to generate the alarm.

A.16 Pyrometer Noise Filtered Rail Alarm

The Pyrometer Noise Filtered Rail alarm indicates that a pyrometer in a bearing scanner might be becoming unreliable.

There is a different Pyrometer Noise Filtered Rail alarm for each rail. That is, there is a Pyrometer Noise Filtered North Rail alarm and a Pyrometer Noise Filtered South Rail alarm (or, depending on track direction, a Pyrometer Noise Filtered East Rail alarm and a Pyrometer Noise Filtered West Rail alarm).

A.17 Pyrometer Noise Filtered Wheel Alarm

The Pyrometer Noise Filtered Wheel alarm indicates that a pyrometer in a wheel scanner might be becoming unreliable.

There is a different Pyrometer Noise Filtered Wheel alarm for each rail. That is, there is a Pyrometer Noise Filtered North Wheel alarm and a Pyrometer Noise Filtered South Wheel alarm (or, depending on track direction, a Pyrometer Noise Filtered East Wheel alarm and a Pyrometer Noise Filtered West Wheel alarm).

A.18 Rail Resistor Test Overridden Alarm

During the post-train resistor test, if a read resistor value isn't greater than 76% of the required resistor value, two additional checks will be performed. The average heats for both bearings are tested against the value set by the **Res Test Minimum Rail Av** option on the Alarm Settings (Advanced) menu.

If the average heats are less than the value set by the **Res Test Minimum Rail Av** option, the system generates a Cold Resistor alarm.

If the average heats are greater than or equal to this value, bearing temperatures are compared on an axle-by-axle basis. This second check determines if more than half of the temperatures read by the bearing scanner with the low-read resistor value are 70% or less than the temperatures read by the other bearing scanner on the same axle. If 50% or more of the axles are low, a Cold Resistor alarm is flagged. If not, a Cold Resistor alarm isn't flagged, but a Rail Resistor Test Overridden alarm is. Both of these tests have to be met to flag a Rail Resistor Test Overridden Alarm.

There is a different Rail Resistor Test Overridden alarm for each rail. That is, there is a North Rail Resistor Test Overridden alarm and a South Rail Resistor Test Overridden alarm (or, depending on track direction, an East Rail Resistor Test Overridden alarm and a West Rail Resistor Test Overridden alarm).

A.19 Reverse Direction Detected Alarm

Trains that are being scanned correctly will have axles whose on times (that is, the time during which an axle passed between the gating transducers) are less than their off times (that is, the time during which no axle passed between the gating transducers). For each axle of a passing train (except for the first axle), the system checks for an on-time that is greater than the off-time. If the axle's on time is greater than its off time, the system reverses the direction locked-in by the first gating pulse, reverses the opening and closing gate assignment for TO1 and TO2, and generates a false transducer pulse. The system considers the gate active for the next axle at the time it determines the current axle's opening gate pulse was missed.

The Reverse Direction Detected alarm indicates that the system entered a state where it is scanning for bearing temperatures when the axles are outside the scanning gate. In this state, the transducer that should be opening the scanning gate is considered by the system to be the transducer that is closing the gate. Likewise, the transducer that should be closing the scanning gate is considered the transducer that is opening the gate.

A.20 Short Train Alarm

The Short Train alarm indicates that a train had fewer than 50 axles.

A.21 Stuck Dragger Recovered Alarm

The Stuck Dragger Recovered alarm indicates that a stuck dragger was detected during train passage and, at some point later, the dragging equipment detector returned to its neutral position for at least eight consecutive Dragger-free axles.

A.22 Test Train Alarm

The Test Train alarm indicates that a given train was generated by the SmartScanNG² system. These trains are used for testing purposes and do not represent actual trains passing the site.

A.23 Successive Cold Wheel Resistors Exceeded Alarm

The Successive Cold Wheel Resistors Exceeded alarm indicates that at least a preset maximum number of consecutive trains, all having Cold Wheel Scanner Resistor alarms on the same raiiside, have passed a site. The user determines the number of consecutive trains used in the comparison through the **Cold Res Counter option** on the Alarm Settings menu.

A.24 Wheel Resistor Test Overridden Alarm

During the post-train resistor test, if a read resistor value isn't greater than 76% of the required resistor value, two additional checks will be performed. The average heats for both wheels are tested against the value set by the **Res Test Minimum Wheel Av** option on the Alarm Settings (Advanced) menu.

If the average heats are less than the value set by the **Res Test Minimum Wheel Av** option, the system generates a Cold Wheel Scanner Resistor alarm.

If the average heats are greater than or equal to this value, wheel temperatures are compared on an axle-by-axle basis. This second check determines if more than half of the temperatures read by the wheel scanner with the low-read resistor value are 70% or less than the temperatures read by the other wheel scanner on the same axle. If 50% or more of the axles are different, a Cold Wheel Scanner Resistor alarm is flagged. If not, a Cold Wheel Scanner Resistor alarm isn't flagged, but a Wheel Resistor Test Overridden alarm is. Both of these tests have to be met to flag a Wheel Resistor Test Overridden Alarm.

There is a different Wheel Resistor Test Overridden alarm for each rail. That is, there is a North Wheel Resistor Test Overridden alarm and a South Wheel Resistor Test Overridden alarm (or, depending on track direction, an East Wheel Resistor Test Overridden alarm and a West Wheel Resistor Test Overridden alarm).

A.25 Very Slow Train Alarm

The Very Slow Train alarm indicates that at some point during train passage, four consecutive axles crossed the gating transducers at a speed of 7 mph (11.3 kph) or less. This will only show up as a System Alarm if the Transducer Type is set to 'Frauscher'. If the Transducer type is 'Magnetic' this will appear as an Integrity Failure.

Appendix B

Integrity Failures

This appendix describes the conditions and events that the SmartScanNG² system flags as Integrity Failures. These alarms indicate conditions in which the integrity of the system, and its ability to record train data accurately, may be compromised. These alarms are listed under the Integrity Failures section of the Train Detail and Exception Detail reports. **Section 6.0 - Producing Reports** tells how to produce these reports. Some Integrity Failures depend on Setup parameters. **Section 4.0 - Serial Interface** tells how to view or change the Setup parameters through the Serial Interface. **Section 5.0 Web User Interface** tells how to print reports and view or change Setup parameters through the web interface.

B.1 Dead Battery Alarm

For 24 VDC Systems:

The **Dead Battery alarm** indicates a float voltage of less than 18 volts on the standby batteries. (The **Low Battery alarm** indicates a float voltage of at least 18 volts, but less than 22 volts, on the standby batteries.)

For 12 VDC Systems:

The **Dead Battery alarm** indicates a float voltage of less than 11.8 volts on the standby battery. (The **Low Battery alarm** indicates a float voltage of at least 11.8 volts, but less than 12.6 volts, on the standby battery.)

B.2 Dead Resistor Alarm

The bearing scanner's Dead Resistor Alarm indicates the presence of two separate conditions. First, the train must contain a Cold Rail alarm on a given rail. Second, there must be a Cold Resistor alarm present on the given rail. For a given rail, Cold Rail plus Cold Resistor equals Dead Resistor. The Cold Resistor alarm is the post-train test done on the recorded resistor temperature using the resistor baseline table.

There is a different Dead Resistor alarm for each rail. That is, there is a Dead North Resistor alarm and a Dead South Resistor alarm (or, depending on track direction, a Dead East Resistor alarm, and a Dead West Resistor alarm).

B.3 Highrange Transducer Miscounts Alarm

The Highrange Transducer Miscounts alarm indicates that the transducer counts for TO1 and TO2 differ by seven or more. This calculation is made after each axle crosses both gating transducers.

The Highrange Transducer Miscounts alarm can be either a System Alarm or an Integrity Failure, depending on the presence of a Very Slow Train alarm. If a highrange transducer miscount occurs on a train that also contains a Very Slow Train alarm, the firmware treats the miscount condition as a System Alarm. This logic assumes that the train's slow rate of travel likely caused the transducer miscount condition. If a Highrange Transducer Miscount occurs on a train that does not also contain a Very Slow Train alarm, the firmware treats the miscount condition as an Integrity Failure.

B.4 Max Equal Heat Test Failures Exceeded Alarm

The Max Equal Heat Test Failures Exceeded alarm indicates that at least a preset **maximum number** of consecutive trains, all having Equal Heats Test Failed alarms, have passed a site. The **maximum number** of consecutive trains, having Equal Heats Test Failed alarms, allowed before generating an Integrity Failure alarm is set by the **Cold Journal Counter** option on the Alarm Settings submenu.

B.5 Maximum Exception Alarms Exceeded Alarm

Exception Alarms are associated with axles. There are eight types. They are the Absolute, Carside Slope, Differential, Dragging-Equipment, High-Load, Hot Wheel, Pyrometer Saturation, and Wide-Load.

The Maximum Exception Alarms Exceeded alarm is generated when the maximum number of Exception Alarms is exceeded on a single train. This maximum number is defined by the **Max Alarms option** on the Alarm Settings (Advanced) submenu.

B.6 Midrange Transducer Miscounts Alarm

The Midrange Transducer Miscounts alarm indicates that the transducer counts for TO1 and TO2 differ by five or six. This calculation is made after each axle crosses both gating transducers.

The Midrange Transducer Miscounts alarm can be either a System Alarm or an Integrity Failure, depending on the presence of a Very Slow Train alarm. If a midrange transducer miscount occurs on a train that also contains a Very Slow Train alarm, the firmware treats the miscount condition as a System Alarm. This logic assumes that the train's slow rate of travel likely caused the transducer miscount condition. If a midrange transducer miscount occurs on a train that does not also contain a Very Slow Train alarm, the firmware treats the miscount condition as an Integrity Failure.

B.7 Pre-train Stuck Dragger Alarm

The Pretrain Stuck Dragger alarm indicates that between the time of first receiving a pulse from the track circuit (or the advance transducers) and the time of first receiving a pulse from either gating transducer, the SmartScanNG² system detected an open circuit from the dragging-equipment detector.

B.8 Pre-train Stuck High-Load Detector Alarm

The Pre-train Stuck High-Load Detector alarm indicates that between the time of first receiving a pulse from the track circuit (or the advance transducers) and the time of first receiving a pulse from either gating transducer, the SmartScanNG² system detected an open circuit from the high-load detector.

B.9 Spike Event

A Spike Event occurs when the detector records less than four axles, but the TO1 or TO2 spike counts exceed four. For example, a train enters the site and fires both transducers (recording one axle), then something takes out the TO1 transducer, leaving only TO2 firing. Each of these hits on TO2 count as spikes (consecutive hits on a given transducer). After the train leaves, the detector has recorded less than four axles (one axle in this case) and counted more than four spikes for a transducer.

B.10 Stuck Dragger During Train Passage Alarm

The Stuck Dragger During Train Passage alarm indicates that a maximum number of consecutive axles had Dragging-Equipment alarms during train passage. The maximum number is defined by the Max Alarms option of the Alarm Settings (Advanced) submenu.

B.11 Pre-train Stuck Wide-Load Detector Alarm

The Pre-train Stuck Wide-Load alarm indicates that between the time of first receiving a pulse from the track circuit (or the advance transducers) and the time of first receiving a pulse from either gating transducer, the SmartScanNG² system detected an open circuit from a wide-load detector.

There is a different Pre-train Stuck Wide-Load alarm for each rail. That is, there is a Pre-train Stuck Wide-Load North Side alarm and a Pre-train Stuck Wide-Load South Side alarm (or, depending on track direction, a Pre-train Stuck Wide-Load East Side alarm and a Pre-train Stuck Wide-Load West Side alarm).

B.12 Successive Cold Rails Exceeded Alarm

The Successive Cold Rails Exceeded alarm indicates that at least a preset maximum number of consecutive trains, all having Cold Rail alarms on the same raiiside, have passed a site. The maximum number (per raiiside) of consecutive trains having Cold Rail alarms allowed before generating an Integrity Failure alarm is set by the **Cold Journal Counter** option on the Alarm Settings menu.

Under normal circumstances, Cold Rail conditions represent System Alarms, not Integrity Failures. However, if the number of consecutive trains bearing the same Cold Rail alarm equals or exceeds the **Cold Journal Counter**, this condition becomes an Integrity Failure.

B.13 Successive Cold Resistors Exceeded Alarm

The Successive Cold Resistors Exceeded alarm indicates that at least a preset maximum number of consecutive trains, all having Cold Resistor alarms on the same raiiside, have passed a site. The maximum number (per raiiside) of consecutive trains having Cold Resistor alarms allowed before generating an Integrity Failure alarm is set by the **Cold Resistor Counter option** on the Alarm Settings menu.

Under normal circumstances, Cold Resistor conditions represent System Alarms, not Integrity Failures. However, if the number of consecutive trains bearing the same Cold Resistor alarm equals or exceeds the **Cold Res Counter** option, this condition becomes an Integrity Failure.

B.14 Train Present on Restart Alarm

The Train Present on Restart alarm indicates that a train was present at the site when the system was starting up.

B.15 Very Slow Train Alarm

The Very Slow Train alarm indicates that at some point during train passage, four consecutive axles crossed the gating transducers at a speed of 7 mph (11.3 kph) or less. If the transducer type is set for 'Frauscher', this will show up as a System Alarm instead of an Integrity Failure.

NOTE: The presence of a Dragger alarm cancels a Very Slow Train alarm.

Appendix C

Replacement of Type II Scanners

There are Type II bearing scanners and Type II wheel scanners. Both contain two major parts. The top part is the cover-and-module assembly. The module and its protective cover are tightly integrated and rarely should be taken apart. Except for the addition of a plastic attenuation plug on the wheel scanner cover, both types of cover-and-module assemblies are identical and can be used interchangeably. The bottom part is the mount. Bearing scanner mounts and wheel scanner mounts are different in design. They can't be interchanged.

This appendix tells how to replace scanner cover-and-module assemblies. The replacement of scanner mounts isn't covered in this guide.

C.1 Bearing Scanners

The figure below shows the major parts of a Type II bearing scanner.

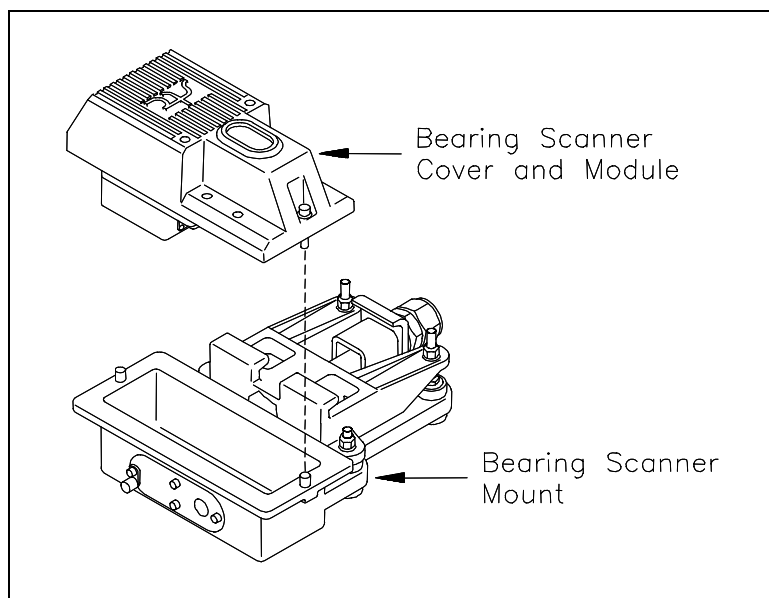

To replace a Type II bearing scanner cover-and-module assembly:

- 1 Be sure that you have on hand a new scanner cover-and-module assembly.
- 2 Be sure that you have on hand a T-handle 1/4-inch hex-wrench.
- 3 Turn off all power to the SmartScanNG² enclosure.
- 4 Using a T-handle 1/4-inch hex-wrench, loosen both socket-head-cap screws on the cover of the bearing scanner.
- 5 Separate the scanner cover-and-module assembly from its mount.

- 6 Disconnect the scanner cable connector from the scanner box connector.

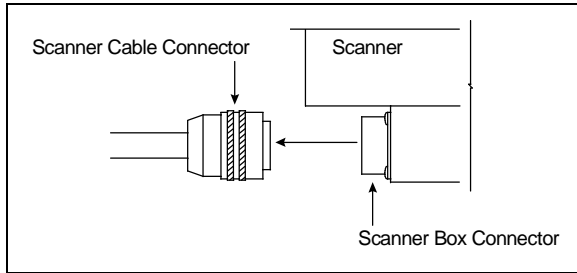

- 7 Store the removed scanner cover-and-module assembly in a safe place until you return it to STC for repair.
- 8 Attach the scanner cable connector to the scanner box connector (on the new scanner cover-and-module assembly).
- 9 With the hole (on top of the scanner cover) facing north or east, replace the scanner cover-and-module assembly onto its mount.

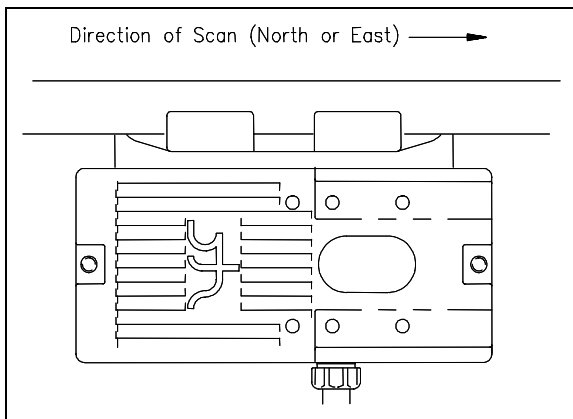

- 10 Using a T-handle 1/4-inch hex-wrench, tighten the two screws (on the scanner cover) until they are completely tight.
- 11 Turn on power to the SmartScanNG² enclosure.

C.2 Wheel Scanners

The figure below shows the major parts of a Type II wheel scanner.

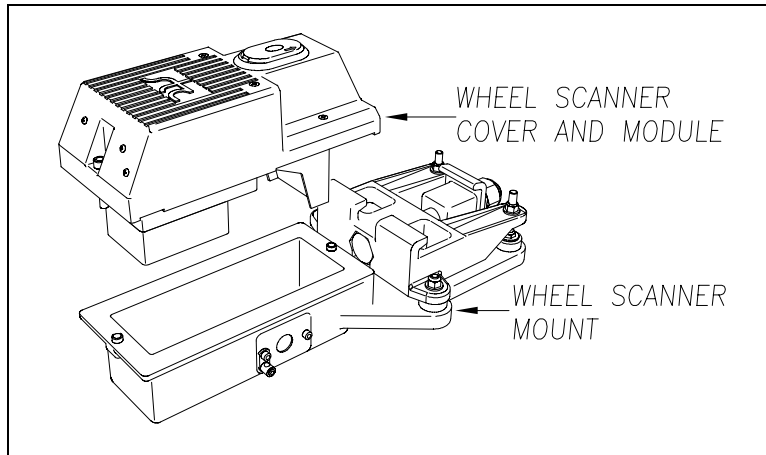

To replace a Type II wheel scanner cover-and-module assembly:

- 1 Be sure that you have on hand a new scanner cover-and-module assembly.
- 2 Be sure that you have on hand a T-handle 1/4-inch hex-wrench.
- 3 Turn off all power to the SmartScanNG² enclosure.
- 4 Using a T-handle 1/4-inch hex-wrench, loosen the two socket-head-cap screws on the cover of the bearing scanner.
- 5 Separate the scanner cover-and-module assembly from its mount.
- 6 Disconnect the scanner cable connector from the scanner box connector.

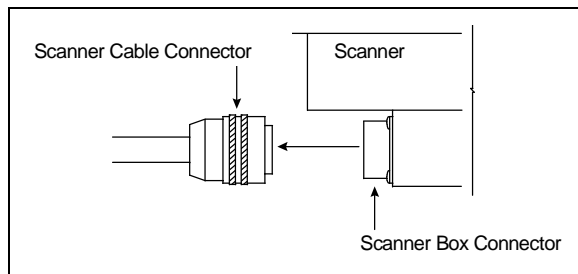

- 7 Store the removed scanner cover-and-module assembly in a safe place until you return it to STC for repair.
- 8 Attach the scanner cable connector to the scanner box connector (on the new scanner cover-and-module assembly).
- 9 With the hole (on top of the scanner cover) facing the center of the track, replace the scanner cover-and-module assembly onto its mount.
- 10 Using a T-handle 1/4-inch hex-wrench, tighten the two screws (on the scanner cover) until they are completely tight.
- 11 Turn on power to the SmartScanNG² enclosure.

Appendix D

Replacement of Type III Scanners

There are Type III bearing scanners and Type III wheel scanners. Both contain two major parts. The top part is the cover-and-module assembly. The module and its protective cover are tightly integrated and rarely should be taken apart. Except for the change of **filter frames** in the wheel scanner module, both types of cover-and-module assemblies are identical and can be used interchangeably. The bottom part is the mount. Bearing scanner mounts and wheel scanner mounts are different in design. They can't be interchanged.

This appendix tells how to replace scanner cover-and-module assemblies. The replacement of scanner mounts isn't covered in this guide.

D.1 Bearing Scanners

The figure below shows the major parts of a bearing scanner.

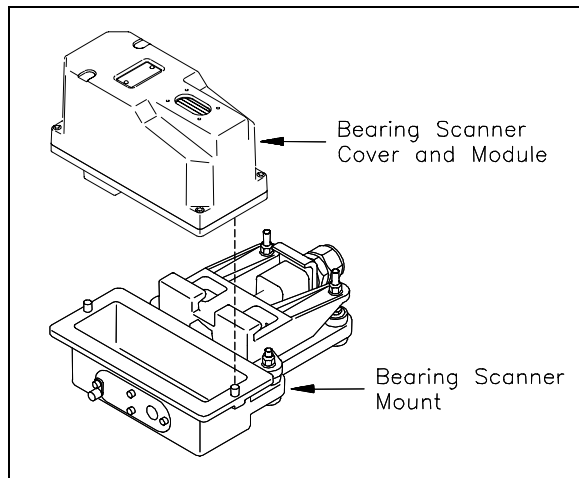

To replace a bearing scanner cover-and-module assembly:

- 1 Be sure that you have on hand a new scanner cover-and-module assembly.
- 2 Be sure that you have on hand a T-handle 1/4-inch hex-wrench.
- 3 Turn off all power to the SmartScanNG² enclosure.
- 4 Using a T-handle 1/4-inch hex wrench, loosen the six socket-head-cap screws on the cover of the bearing scanner.

Four screws attach the weather cover to the mounting plate, and two screws attach the mounting plate to the mount.

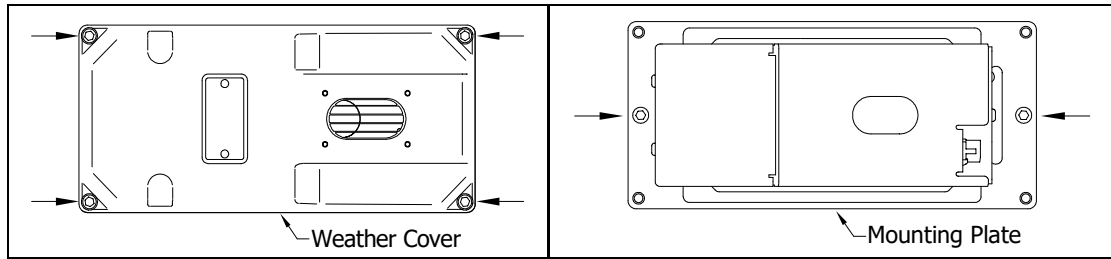

- 5 Separate the bearing scanner cover-and-module assembly from its mount.
- 6 Disconnect the heater wiring plug.
- 7 Disconnect the scanner cable connector from the scanner box connector.

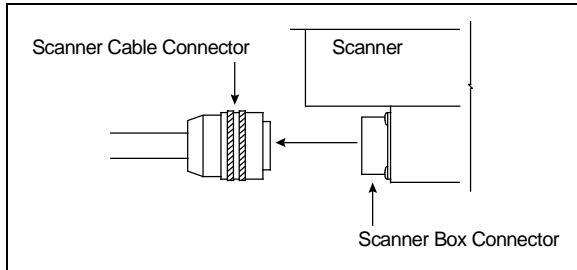

- 8 Store the removed scanner cover-and-module assembly in a safe place until you return it to STC for repair.
- 9 Attach the scanner cable connector to the scanner box connector of the new scanner cover-and-module assembly.
- 10 With the hole on top of the bearing scanner cover facing north or east, set the mounting plate back onto its scanner mount.
- 11 Using the T-handle 1/4-inch hex-wrench, uniformly tighten the two socket-head-cap screws.
- 12 Reconnect the heater wiring plug.
- 13 With the hole on top of the bearing scanner cover facing north or east, set the weather cover back onto its mounting plate.
- 14 Using the T-handle 1/4-inch hex-wrench, uniformly tighten the four socket-head-cap screws.

The top view of the bearing scanner mounting plate and weather cover is shown below.

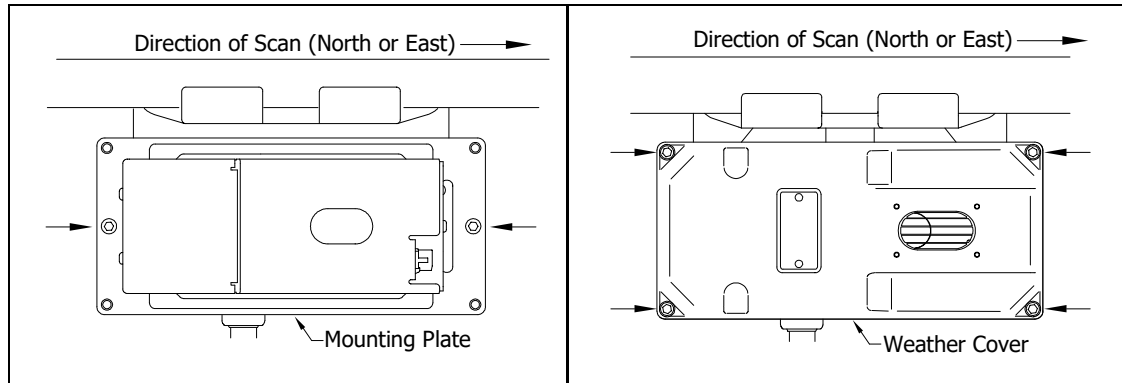

15 Turn on power to the scanners.

An assembled bearing scanner looks like this.

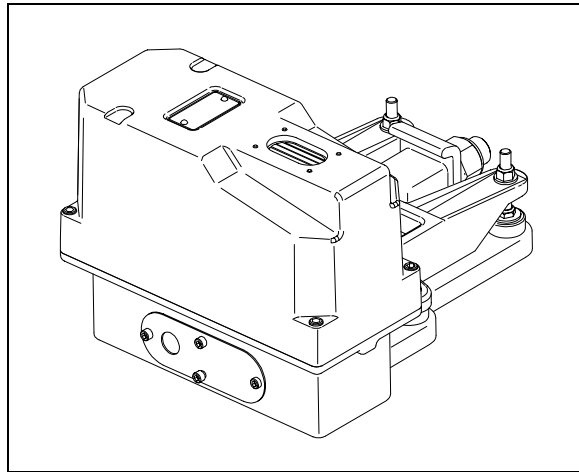

D.2 Wheel Scanners

The figure below shows the major parts of a wheel scanner.

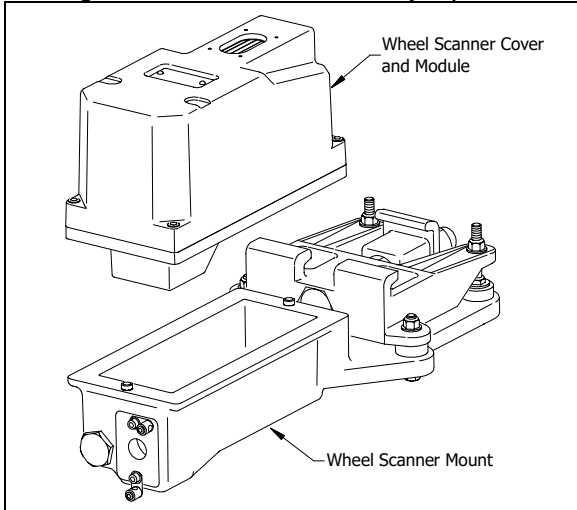

To replace a wheel scanner cover-and-module assembly:

- 1 Be sure that you have on hand a new scanner cover-and-module assembly.
- 2 Be sure that you have on hand a T-handle 1/4-inch hex-wrench.
- 3 Turn off all power to the scanners.

This requires turning off the DC power switch on the SmartScanNG² enclosure and unplugging the AC power cord on the bottom of the SmartScanNG² enclosure.

- 4 Using a T-handle 1/4-inch hex wrench, loosen the six socket-head-cap screws on the cover of the wheel scanner.

Four screws attach the weather cover to the mounting plate, and two screws attach the mounting plate to the mount.

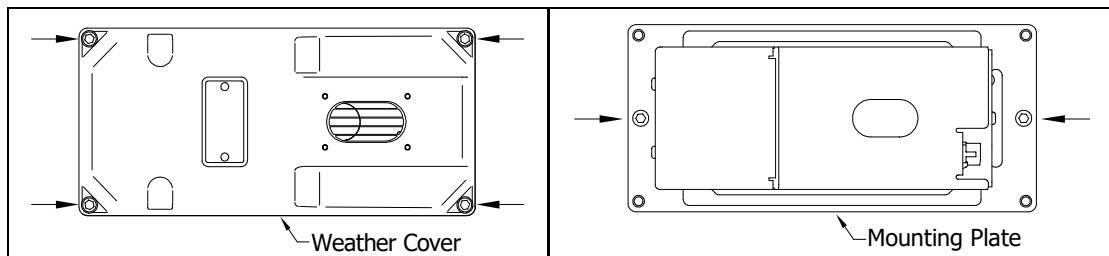

- 5 Separate the wheel scanner cover-and-module assembly from its mount.
- 6 Disconnect the heater wiring plug.
- 7 Disconnect the scanner cable connector from the scanner box connector.

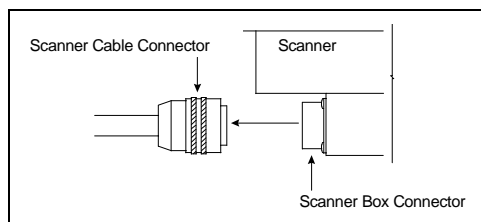

- 8** Store the removed scanner cover-and-module assembly in a safe place until you return it to STC for repair.
- 9** Attach the scanner cable connector to the scanner box connector of the new scanner cover-and-module assembly.
- 10** With the hole on top of the wheel scanner cover facing the center of the track, set the mounting plate back onto its scanner mount.
- 11** Using the T-handle 1/4-inch hex-wrench, uniformly tighten the two socket-head-cap screws.
- 12** Reconnect the heater wiring plug.
- 13** With the hole on top of the wheel scanner cover facing the center of the track, set the weather cover back onto its mounting plate.
- 14** Using the T-handle 1/4-inch hex-wrench, uniformly tighten the four socket-head-cap screws.
- 15** Turn on power to the SmartScanNG² enclosure.

Appendix E

Calibration of Type II Scanners

The SmartScanNG² system self-calibrates its pyrometer interface circuitry. You need only put a preheated calibrated heat source on a scanner and place the system in autocalibration mode. The system then scans all pyrometer inputs until the signal from the calibrated heat source is located. The necessary adjustments to the related interface circuitry are automatically made while the system monitors its own progress by analyzing changes in the heat signals. Once the procedure has been completed, autocalibration mode is disengaged, and the calibration results are displayed on your computer.

This appendix tells how to use the calibrated heat source to calibrate the scanners.

E.1 Type II Bearing Scanners

STC recommends that you use the calibrated heat source (2100-810NG) only when the outside (ambient) temperature is above -18°C (0°F) and below 32°C (90°F). If you must use it at other times, do so only when the needle is centered on the front of the temperature meter. If the needle isn't stabilized within ± 2 degrees of the set point, the heat source isn't operating properly.

To calibrate a bearing scanner:

- 1 Be sure that you have on hand an STC calibrated heat source (2100-810NG) and a laptop computer.
- 2 On the control panel of the calibrated heat source, toggle the **Gating** switch off.
- 3 Plug the proper end of the supplied 50-foot (15-meter) power cord into the **six**-contact circular connector on the front of the calibrated heat source.

Sixty Hz is critical for proper operation. For a site that doesn't have a 120-volt 60-Hz power source, the heat source should be powered from a true sine wave inverter capable of 250 watts with an output of at least 110 volts at 60 Hz. The inverter should operate from an input voltage of 10.5 VDC to 15 VDC. A 120-volt USA socket should be provided to match the heat source power cord. The inverter should be grounded according to the manufacturer's recommendations.

WARNING

Once plugged in, both function connectors will have live AC present.

- 4 Using the supplied dust cap, cover the function connector that isn't being used.
- 5 Plug the other end of the power cord into the 120-volt USA socket.
- 6 On the control panel of the calibrated heat source, turn the temperature knob to **180°**.

- 7 Put the heat source in a shady area, out of direct sunlight and out of the wind.
- 8 Wait about 8 minutes for the heat source to reach operating temperature and stabilize.

The heat source has reached operating temperature and stabilized when the temperature meter needle remains centered.

Once the temperature stabilizes, calibration may begin. Once stabilized, the temperature will change less than plus-or-minus one degree Fahrenheit.

- 9 Orient the power cord as depicted and place the calibrated heat source on the bearing scanner.

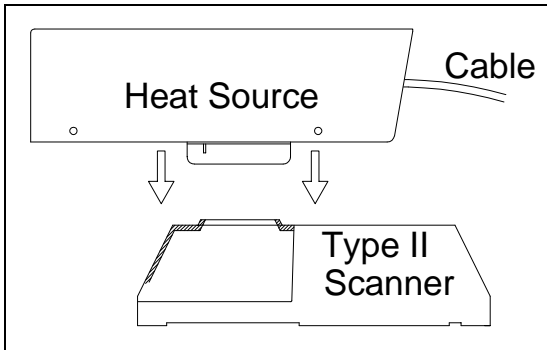

- 10 To prepare your computer:
 - a Plug your computer into COM1 using a null-modem cable.
 - b Turn on your computer.
 - c Be sure that your computer has installed communications software, that it is set to use full-duplex, and that the baud rate is set to the appropriate setting (factory default is 19,200).
- 11 Using the serial interface, display the Main menu. Select **Systems Functions Menu**.

The Main menu looks like this.

```
Main Menu - Comm
-----
          .
          .
[L] - System Functions Menu
[M] - Replay train
[N] - Security Menu
[X] - Exit
```

Select **Auto-calibration** to calibrate the system's pyrometer interface circuitry.

The SmartScanNG² system will now calibrate itself. **Follow along on your computer screen until you see "Auto-Calibration Disengaged."** This message is an indication that the system is done with the calibration procedure. To abort the process, press **[Esc]** on your computer or remove the heat source from the bearing scanner.

```
System Functions Menu
-----
[A] - Radio/Audio Menu
[B] - Start Manual Train
[C] - Auto-Calibration
[D] - Reboot System
[E] - Delete All Stored Train Data
[F] - Clear Event Log
[G] - Update Menu
[H] - Maintenance Menu
[I] - Resistor Baseline Data
[J] - Scanner Test
[K] - Calibrate Frauscher Transducers
[L] - Virtual Gate Test
[M] - AUX OUT Relay Menu
[X] - Exit
```

The handling of a scanner calibration request depends on the current battery voltage. Calibration requests are handled as follows:

- **Battery Okay:** Calibration proceeds normally.
- **Battery Low:** A message displays the current battery voltage and the Low Battery threshold, and a prompt asks the user whether to continue. If the user chooses to continue, the firmware records a "Scanner calibration requested during Low Battery (nn.nV) condition" Event Log entry where the current battery voltage appears in place of "nn.n." The following screenshot shows an example of the new displays.

```
System Functions Menu
-----
      .
      .
[F] - Auto-Calibration
      .
      .

[X] - Exit

Battery voltage (12.2V) is below the Low Battery threshold (12.6V).
Calibration is not advised. Continue with calibration? (y/n)
- or for 24V systems -
Battery voltage (19.3V) is below the Low Battery threshold (22.0V).
Calibration is not advised. Continue with calibration? (y/n)
```

OLED Keypad

```
Battery Low (12.3V)
Calibration Is Not
Advised
Press Select to Cont
```

Web Interface

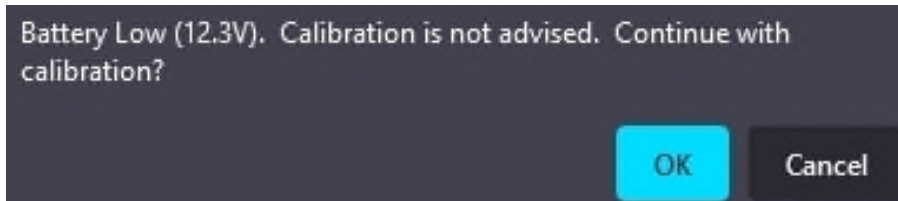

```
Battery Low (12.3V). Calibration is not advised. Continue with
calibration?
```

OK Cancel

Calibrating during a Low Battery condition will further drain battery power, shortening the time the detector remains operating. Additionally, the resistor baseline values used during the post-train resistor integrity test correspond to the battery voltage used during acquisition of the baseline values. Gathering baseline values (which begins following calibration) during a Low Battery condition yields values that will not correspond to the values needed when the battery voltage returns to its normal operating level.

- **Battery Dead:** A message displays the current battery voltage and the Dead Battery threshold. The firmware now prohibits calibration during a Dead Battery condition. The following screenshot shows an example of the new displays.

```
Battery voltage (11.2V) is below the Dead Battery threshold (11.8V).
- or for 24V systems -
Battery voltage (16.8V) is below the Dead Battery threshold (18.0V).
!!! Calibration Prohibited !!!
```

The firmware will not open the scanner shutters once the battery voltage drops below the Dead Battery threshold. It does this to conserve battery power and keep the detector running for as long as possible. While running, the detector continues recording axles, scanning for auxiliary alarms, making voice announcements, and (if equipped) communicating with a central office.

OLED Keypad

```
Battery Dead (11.3V)
!!! Calibration !!!
!!! Prohibited !!!
Press Func to Exit
```

Web Interface

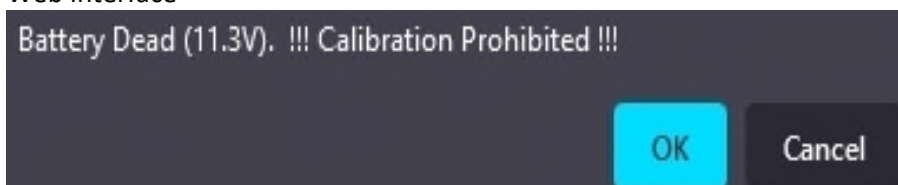

```
Battery Dead (11.3V). !!! Calibration Prohibited !!!
```

OK Cancel

On your computer screen, an acceptable calibration looks like this. Your values will be different.

```

Auto Calibration Selected
Scanner Types
-----
Rail-1..... Type-II   Rail-2..... Type-III
Wheel-1..... Type-III  Wheel-2..... Type-II

Is this correct ?

Signal levels in millivolts with closed shutters
      Rail1           Rail2           Wheel1           Wheel2
Min/Max/Average  Min/Max/Average  Min/Max/Average  Min/Max/Average
0  80  20    0  60  20    0  60  20    20  80  40

Opening the shutters.
Scanning for heat source. Press the 'Esc' key to abort.
Located 187F heat source at Rail1. Auto-calibration beginning in 0 secs.

.....Auto-Calibration Engaged.....

Testing Digital-Pot U-306. Stand by.
Digital-pot checks OK.
Previous calibrated digital-pot. setting was 38.
Adjusting digital-pot.
Temp = 225F  Pot = 59  Sec = 1  Pot. decremented by 1 step.
Temp = 224F  Pot = 58  Sec = 1  Pot. decremented by 1 step.
Temp = 221F  Pot = 57  Sec = 2  Pot. decremented by 1 step.
Temp = 219F  Pot = 56  Sec = 3  Pot. decremented by 1 step.
      .
      .
Temp = 183F  Pot = 35  Sec = 15  Pot. decremented by 1 step.
Temp = 182F  Pot = 34  Sec = 18  Pot. decremented by 1 step.
Temp = 181F  Pot = 33  Sec = 29  Pot. decremented by 1 step.
Temp = 179F  Pot = 33  Sec = 93  Monitoring heat source temperature.
Rail1 digital-pot setting of 33 was stored in EEPROM.
East Rail Scanner Calibration complete.
The setpoint is 180F. The calibrated temp. is 179F.
Closing the shutters.
Resistor test pending.

.....Auto-Calibration Disengaged.....

```

Before the shutters are opened, if you get a signal level greater than 200 millivolts, it usually means that there is noise on the scanner inputs, which most times is caused by an electrical problem with the scanner. If you cannot isolate and fix the cause of this problem, call STC for help.

```

Auto Calibration Selected

Signal levels in millivolts with closed shutters
      Rail1           Rail2           Wheel1           Wheel2
Min/Max/Average  Min/Max/Average  Min/Max/Average  Min/Max/Average
210 250  210    0  60  20    0  60  20    20  80  40
      .
      .

```

Before the shutters are closed, if you don't get a calibrated temperature in the range 178°F to 182°F, it means that the scanner wasn't calibrated. If cleaning the optics doesn't solve your problem, replace the scanner cover-and-module assembly. If this doesn't solve your problem, call STC for help in fixing the problem.

- 12 When "Auto-Calibration Disengaged" is displayed on your computer, remove the calibrated heat source.
- 13 To return to the Main menu, type **X**.
- 14 To exit the serial interface and return the system to normal operation, type **X**.
- 15 Store the calibrated heat source and its power cord in the wayside enclosure.

NOTE:

Upon completion of autocalibration, the system acquires the scanner resistor temperature baseline values. The process begins with a 20-minute wait period in which the resistors are allowed to cool down. The system counts down during this period, sounding a tone each minute. After the 20-minute cool down period, the system opens and closes the shutters for a period of 8 minutes.

Covering the apertures of all four scanners during the baseline acquisition routine should result in a more accurate baseline measurement because the reference for the scanner is stable when covered. See **Appendix J** for a detailed explanation and instructions.

E.2 Type II Wheel Scanners

STC recommends that you use the calibrated heat source (2100-810NG) only when the outside (ambient) temperature is above -18°C (0°F) and below 32°C (90°F). If you must use it at other times, do so only when the needle is centered on the front of the temperature meter. If the needle isn't stabilized within ± 2 degrees of the set point, the heat source isn't operating properly.

To calibrate a wheel scanner:

- 1 Be sure that you have on hand an STC calibrated heat source (2100-810NG) and a laptop computer.
- 2 On the control panel of the calibrated heat source, toggle the **Gating** switch off.
- 3 Plug the proper end of the supplied 50-foot (15-meter) power cord into the **six**-contact circular connector on the front of the calibrated heat source.

Sixty Hz is critical for proper operation. For a site that doesn't have a 120-volt 60-Hz power source, the heat source should be powered from a true sine wave inverter capable of 250 watts with an output of at least 110 volts at 60 Hz. The inverter should operate from an input voltage of 10.5 VDC to 15 VDC. A 120-volt USA socket should be provided to match the heat source power cord. The inverter should be grounded according to the manufacturer's recommendations.

WARNING

Once plugged in, both function connectors will have live AC present.

- 4 Using the supplied dust cap, cover the function connector that isn't being used.
- 5 Plug the other end of the power cord into the 120-volt USA socket.
- 6 On the control panel of the calibrated heat source, turn the temperature knob to **180°**.
- 7 Put the heat source in a shady area, out of direct sunlight and out of the wind.
- 8 Wait about 8 minutes for the heat source to reach operating temperature and stabilize.

The heat source has reached operating temperature and stabilized when the temperature meter needle remains centered.

Once the temperature stabilizes, calibration may begin. Once stabilized, the temperature will change less than plus-or-minus one degree Fahrenheit.

You'll need to remove the weather cover before you can replace the filter frame. Four socket-head-cap screws attach the weather cover to the mounting plate. Before continuing, be sure that the black filter frame is securely in place and that the four socket-head-cap screws on the weather cover are completely tight.

- 9 Remove the attenuation plug from the wheel scanner.

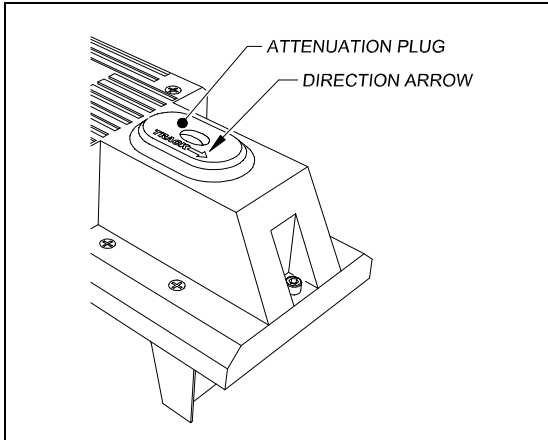

- 10 Orient the power cord as depicted and place the calibrated heat source on the wheel scanner.

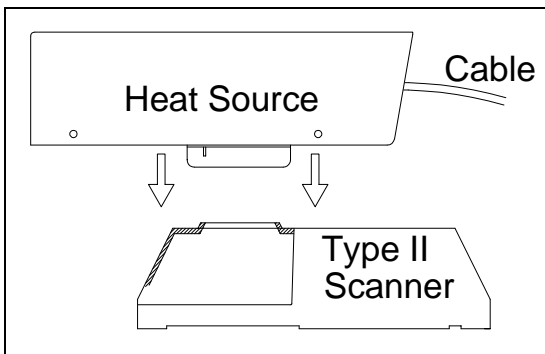

- 11 To prepare your computer:
- a Plug your computer into COM1 using a null-modem cable.
 - b Turn on your computer.
 - c Be sure that your computer has installed communications software, that it is set to use full-duplex, and that the baud rate is set to the appropriate setting (factory default is 19,200).

12 Using the serial interface, display the Main menu.

The Main menu looks like this.

```
Main Menu - Comm
-----
      .
      .
      .
[K] - Event log
[L] - System Functions Menu
[M] - Replay train
[N] - Security Menu
[X] - Exit
```

13 Select the **Auto-Calibration option** to calibrate the system's pyrometer interface circuitry.

The SmartScanNG² system will now calibrate itself. **Follow along on your computer screen until you see "Auto-Calibration Disengaged."** This message is an indication that the system is done with the calibration procedure. To abort the process, press **[Esc]** on your computer or remove the heat source from the wheel scanner.

Before the shutters are opened, if you get a signal level greater than 200 millivolts, it usually means that there is noise on the scanner inputs, which most times is caused by an electrical problem with the scanner. If you cannot isolate and fix the cause of this problem, call STC for help.

```
System Functions Menu
-----
[A] - Radio/Audio Menu
[B] - Start Manual Train
[C] - Auto-Calibration
[D] - Reboot System
[E] - Delete All Stored Train Data
[F] - Clear Event Log
[G] - Update Menu
[H] - Maintenance Menu
[I] - Resistor Baseline Data
[J] - Scanner Test
[K] - Calibrate Frauscher Transducers
[L] - Virtual Gate Test
[M] - AUX OUT Relay Menu
[X] - Exit
```

The handling of a scanner calibration request depends on the current battery voltage. Calibration requests are handled as follows:

- **Battery Okay:** Calibration proceeds normally.
- **Battery Low:** A message displays the current battery voltage and the Low Battery threshold, and a prompt asks the user whether to continue. If the user chooses to continue, the firmware records a "Scanner calibration requested during Low Battery (nn.nV) condition" Event Log entry where the current battery voltage appears in place of "nn.n." The following screenshot shows an example of the new displays.

```
System Functions Menu
-----
      .
      .
[F] - Auto-Calibration
      .
      .
[X] - Exit

Battery voltage (12.2V) is below the Low Battery threshold (12.6V).
Calibration is not advised. Continue with calibration? (y/n)
- or for 24V systems -
Battery voltage (19.3V) is below the Low Battery threshold (22.0V).
Calibration is not advised. Continue with calibration? (y/n)
```

Calibrating during a Low Battery condition will further drain battery power, shortening the time the detector remains operating. Additionally, the resistor baseline values used during the post-train resistor integrity test correspond to the battery voltage used during the acquisition of the baseline values. Gathering baseline values (which begins following calibration) during a Low Battery condition yields values that will not correspond to the values needed when the battery voltage returns to its normal operating level.

- **Battery Dead:** A message displays the current battery voltage and the Dead Battery threshold. The firmware now prohibits calibration during a Dead Battery condition. The following screenshot shows an example of the new displays.

```
Battery voltage (11.2V) is below the Dead Battery threshold (11.8V).
- or for 24V systems -
Battery voltage (16.8V) is below the Dead Battery threshold (18.0V).
!!! Calibration Prohibited !!!
```

The firmware will not open the scanner shutters once the battery voltage drops below the Dead Battery threshold. It does this to conserve battery power and keep the detector running for as long as possible. While running, the detector continues recording axles, scanning for auxiliary alarms, making voice announcements, and (if equipped) communicating with a central office.

Before the shutters are closed, if you don't get a calibrated temperature in the range 178°F to 182°F, it means that the scanner wasn't calibrated. If cleaning the optics doesn't solve your problem, replace the scanner cover-and-module assembly. If this doesn't solve your problem, call STC for help in fixing the problem.

- 14 When "Auto-Calibration Disengaged" is displayed on your computer, remove the calibrated heat source.
- 15 Replace the attenuation plug.
The attenuation plug has a direction arrow molded into the top of the plug. This arrow should be pointing toward the rail.
- 16 To return to the Main menu, type **X**.
- 17 To exit the serial interface and return the system to normal operation, type **X**.
- 18 Store the calibrated heat source and its power cord in the wayside enclosure.

NOTE:

Upon completion of autocalibration, the system acquires the scanner resistor temperature baseline values. The process begins with a 20-minute wait period in which the resistors are allowed to cool down. The system counts down during this period, sounding a tone each minute. After the 20-minute cool-down period, the system opens and closes the shutters for a period of 8 minutes.

Covering the apertures of all four scanners during the baseline acquisition routine should result in a more accurate baseline measurement because the reference for the scanner is stable when covered. See **Appendix J** for a detailed explanation and instructions.

E.3 Heat Source: Power Cable Warning

Warning - Caution

**PLEASE – ONLY USE THE POWER CORD
THAT WAS SHIPPED WITH THIS HEAT
SOURCE.**

USE OF THE OLD CORD WITH PINS IN THE
CONNECTOR WILL DAMAGE THIS HEAT SOURCE

The old-style power cord is a shock hazard because the connector is not “finger-safe.” As a result, the connectors on both the power cord and the heat source were changed.



Old-style plug with pins.

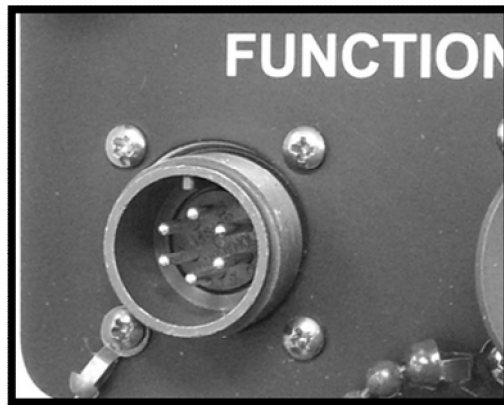

New heat source with pins.

If an old-style cable is forcibly connected to a new heat source, the reverse polarity of the mating connector pins will damage the heat source.

Appendix F

Calibration of Type III Scanners

The SmartScanNG² system self-calibrates its pyrometer interface circuitry. You need only put a preheated calibrated heat source on a scanner and place the system in autocalibration mode. The system then scans all pyrometer inputs until the signal from the calibrated heat source is located. The necessary adjustments to the related interface circuitry are automatically made while the system monitors its own progress by analyzing changes in the heat signals. Once the procedure has been completed, autocalibration mode is disengaged, and the calibration results are displayed on your computer.

This appendix tells how to use the calibrated heat source to calibrate the scanners.

F.1 Bearing Scanners

STC recommends that you use the calibrated heat source (2100-810NG) only when the outside (ambient) temperature is above -18°C (0°F) and below 32°C (90°F). If you must use it at other times, do so only when the needle is centered on the front of the temperature meter. If the needle isn't stabilized within ± 2 degrees of the set point, the heat source isn't operating properly.

To calibrate a bearing scanner:

- 1 Be sure that you have on hand an STC calibrated heat source (2100-810NG) and a laptop computer.
- 2 On the control panel of the calibrated heat source, toggle the **Gating** switch off.
- 3 Plug the proper end of the supplied 50-foot (15-meter) power cord into the **six**-contact circular connector on the front of the calibrated heat source.

Sixty Hz is critical for proper operation. For a site that doesn't have a 120-volt 60-Hz power source, the heat source should be powered from a true sine wave inverter capable of 250 watts with an output of at least 110 volts at 60 Hz. The inverter should operate from an input voltage of 10.5 VDC to 15 VDC. A 120-volt USA socket should be provided to match the heat source power cord. The inverter should be grounded according to the manufacturer's recommendations.

WARNING

Once plugged in, both function connectors will have live AC present.

- 4 Using the supplied dust cap, cover the function connector that isn't being used.
- 5 Plug the other end of the power cord into the 120-volt USA socket.
- 6 On the control panel of the calibrated heat source, turn the temperature knob to **180°**.

- 7 Put the heat source in a shady area, out of direct sunlight and out of the wind.
- 8 Wait about 8 minutes for the heat source to reach operating temperature and stabilize.

The heat source has reached operating temperature and stabilized when the temperature meter needle remains centered.

Once the temperature stabilizes, calibration may begin. Once stabilized, the temperature will change less than plus-or-minus one degree Fahrenheit.

- 9 With the power cord to the front of the scanner, place the calibrated heat source on the bearing scanner.

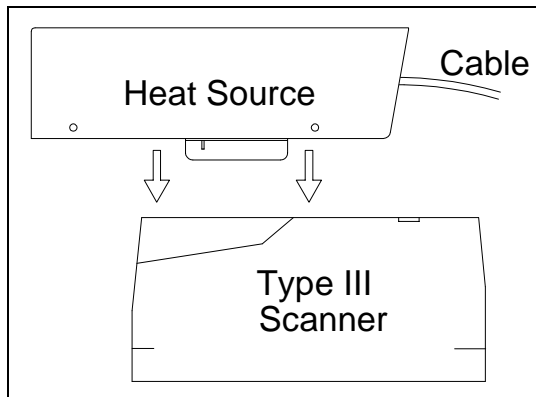

- 10 To prepare your computer:
 - a Plug your computer into COM1 using a null-modem cable.
 - b Turn on your computer.
 - c Be sure that your computer has installed communications software, that it is set to use full-duplex, and that the baud rate is set to the appropriate setting (factory default is 19,200).
- 11 Using the serial interface, display the Main menu.

The Main menu looks like this.

```
Main Menu - Comm
-----
          .
          .
          .
[L] - System Functions Menu
[M] - Replay train
[N] - Security Menu
[X] - Exit
```

12 Select **Auto-calibration** to calibrate the system's pyrometer interface circuitry.

The SmartScanNG² system will now calibrate itself. **Follow along on your computer screen until you see "Auto-Calibration Disengaged."** This message is an indication that the system is done with the calibration procedure. To abort the process, press **[Esc]** on your computer or remove the heat source from the bearing scanner.

```
System Functions Menu
-----
[A] - Radio/Audio Menu
[B] - Start Manual Train
[C] - Auto-Calibration
[D] - Reboot System
[E] - Delete All Stored Train Data
[F] - Clear Event Log
[G] - Update Menu
[H] - Maintenance Menu
[I] - Resistor Baseline Data
[J] - Scanner Test
[K] - Calibrate Frauscher Transducers
[L] - Virtual Gate Test
[M] - AUX OUT Relay Menu
[X] - Exit
```

The handling of a scanner calibration request depends on the current battery voltage. Calibration requests are handled as follows:

- **Battery Okay:** Calibration proceeds normally.
- **Battery Low:** A message displays the current battery voltage and the Low Battery threshold, and a prompt asks the user whether to continue. If the user chooses to continue, the firmware records a "Scanner calibration requested during Low Battery (nn.nV) condition" Event Log entry where the current battery voltage appears in place of "nn.n." The following screenshot shows an example of the new displays.

```
System Functions Menu
-----
      .
      .
[F] - Auto-Calibration
      .
      .
[X] - Exit

Battery voltage (12.2V) is below the Low Battery threshold (12.6V).
Calibration is not advised. Continue with calibration? (y/n)
- or for 24V systems -
Battery voltage (19.3V) is below the Low Battery threshold (22.0V).
Calibration is not advised. Continue with calibration? (y/n)
```

Calibrating during a Low Battery condition will further drain battery power, shortening the time the detector remains operating. Additionally, the resistor baseline values used during the post-train resistor integrity test correspond to the battery voltage used during the acquisition of the baseline values. Gathering baseline values (which begins following calibration) during a Low Battery condition yields values that will not correspond to the values needed when the battery voltage returns to its normal operating level.

- **Battery Dead:** A message displays the current battery voltage and the Dead Battery threshold. The firmware now prohibits calibration during a Dead Battery condition. The following screenshot shows an example of the new displays.

```
Battery voltage (11.2V) is below the Dead Battery threshold (11.8V).  
- or for 24V systems -  
Battery voltage (16.8V) is below the Dead Battery threshold (18.0V).  
!!! Calibration Prohibited !!!
```

The firmware will not open the scanner shutters once the battery voltage drops below the Dead Battery threshold. It does this to conserve battery power and keep the detector running for as long as possible. While running, the detector continues recording axles, scanning for auxiliary alarms, making voice announcements, and (if equipped) communicating with a central office.

On your computer screen, an acceptable calibration looks like this. Your values will be different.

```

Auto Calibration Selected
Scanner Types
-----
Rail-1..... Type-II   Rail-2..... Type-III
Wheel-1..... Type-III  Wheel-2..... Type-II

Is this correct ?

Signal levels in millivolts with closed shutters
      Rail1           Rail2           Wheel1           Wheel2
Min/Max/Average  Min/Max/Average  Min/Max/Average  Min/Max/Average
0  80  20    0  60  20    0  60  20    20  80  40

Opening the shutters.
Scanning for heat source. Press the 'Esc' key to abort.
Located 187F heat source at Rail1. Auto-calibration beginning in 0 secs.

.....Auto-Calibration Engaged.....

Testing Digital-Pot U-306. Stand by.
Digital-pot checks OK.
Previous calibrated digital-pot. setting was 38.
Adjusting digital-pot.
Temp = 225F  Pot = 59  Sec = 1  Pot. decremented by 1 step.
Temp = 224F  Pot = 58  Sec = 1  Pot. decremented by 1 step.
Temp = 221F  Pot = 57  Sec = 2  Pot. decremented by 1 step.
Temp = 219F  Pot = 56  Sec = 3  Pot. decremented by 1 step.
.
.
Temp = 183F  Pot = 35  Sec = 15  Pot. decremented by 1 step.
Temp = 182F  Pot = 34  Sec = 18  Pot. decremented by 1 step.
Temp = 181F  Pot = 33  Sec = 29  Pot. decremented by 1 step.
Temp = 179F  Pot = 33  Sec = 93  Monitoring heat source temperature.
Rail1 digital-pot setting of 33 was stored in EEPROM.
East Rail Scanner Calibration complete.
The setpoint is 180F. The calibrated temp. is 179F.
Closing the shutters.
Resistor test pending.

.....Auto-Calibration Disengaged.....

```

Before the shutters are opened, if you get a signal level greater than 200 millivolts, it usually means that there is noise on the scanner inputs, which most times is caused by an electrical problem with the scanner. If you cannot isolate and fix the cause of this problem, call STC for help.

```

Auto Calibration Selected

Signal levels in millivolts with closed shutters
      Rail1           Rail2           Wheel1           Wheel2
Min/Max/Average  Min/Max/Average  Min/Max/Average  Min/Max/Average
210 250 210    0  60  20    0  60  20    20  80  40
.
.
.

```

Before the shutters are closed, if you don't get a calibrated temperature in the range of 178°F to 182°F, it means that the scanner wasn't calibrated. If cleaning the optics doesn't solve your problem, replace the scanner cover-and-module assembly. If this doesn't solve your problem, call STC for help in fixing the problem.

- 13 When "Auto-Calibration Disengaged" is displayed on your computer, remove the calibrated heat source.
- 14 To return to the Main menu, type **X**.
- 15 To exit the serial interface and return the system to normal operation, type **X**.
- 16 Store the calibrated heat source and its power cord in the wayside enclosure.

NOTE:

Upon completion of autocalibration, the system acquires the scanner resistor temperature baseline values. The process begins with a 20-minute wait period in which the resistors are allowed to cool down. The system counts down during this period, sounding a tone each minute. After the 20-minute cool-down period, the system opens and closes the shutters for a period of 8 minutes.

Covering the apertures of all four scanners during the baseline acquisition routine should result in a more accurate baseline measurement because the reference for the scanner is stable when covered. See **Appendix J** for a detailed explanation and instructions.

F.2 Wheel Scanners

STC recommends that you use the calibrated heat source (2100-810NG) only when the outside (ambient) temperature is above -18°C (0°F) and below 32°C (90°F). If you must use it at other times, do so only when the needle is centered on the front of the temperature meter. If the needle isn't stabilized within ± 2 degrees of the setpoint, the heat source isn't operating properly.

To calibrate a wheel scanner:

- 1 Be sure that you have on hand an STC calibrated heat source (2100-810NG) and a laptop computer.
- 2 On the control panel of the calibrated heat source, toggle the **Gating** switch off.
- 3 Plug the proper end of the supplied 50-foot (15-meter) power cord into the **six**-contact circular connector on the front of the calibrated heat source.

Sixty Hz is critical for proper operation. For a site that doesn't have a 120-volt 60-Hz power source, the heat source should be powered from a true sine wave inverter capable of 250 watts with an output of at least 110 volts at 60 Hz. The inverter should operate from an input voltage of 10.5 VDC to 15 VDC. A 120-volt USA socket should be provided to match the heat source power cord. The inverter should be grounded according to the manufacturer's recommendations.

WARNING

Once plugged in, both function connectors will have live AC present.

- 4 Using the supplied dust cap, cover the function connector that isn't being used.
- 5 Plug the other end of the power cord into the 120-volt USA socket.
- 6 On the control panel of the calibrated heat source, turn the temperature knob to **180°**.
- 7 Put the heat source in a shady area, out of direct sunlight and out of the wind.
- 8 Wait about 8 minutes for the heat source to reach operating temperature and stabilize.

The heat source has reached operating temperature and stabilized when the temperature meter needle remains centered.

Once the temperature stabilizes, calibration may begin. Once stabilized, the temperature will change less than plus-or-minus one degree Fahrenheit.

- 9 Replace the red filter frame with the black one during calibration.

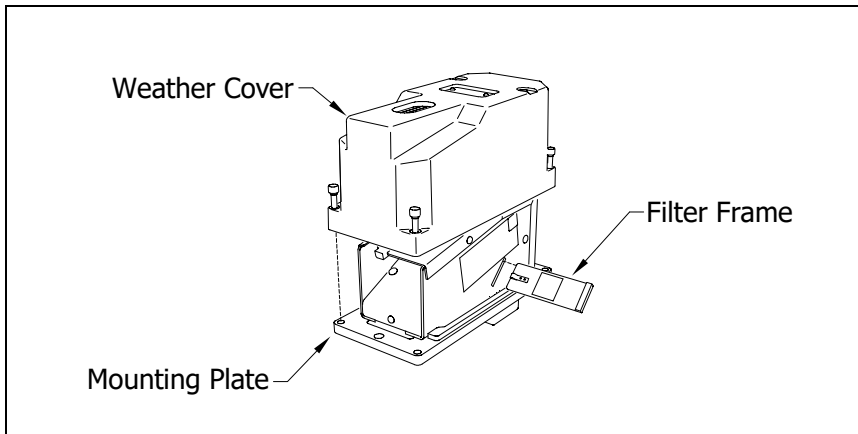

You'll need to remove the weather cover before you can replace the filter frame. Four socket-head-cap screws attach the weather cover to the mounting plate. Before continuing, be sure that the black filter frame is securely in place and that the four socket-head-cap screws on the weather cover are completely tight.

- 10 Re With the power cord to the front of the scanner, place the calibrated heat source on the wheel scanner

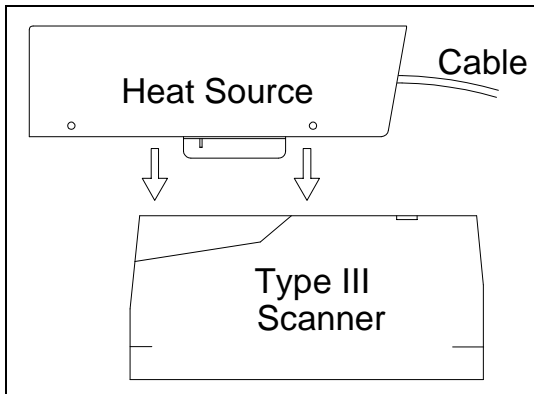

- 11 To prepare your computer:
 - a Plug your computer into COM1 using a null-modem cable.
 - b Turn on your computer.
 - c Be sure that your computer has installed communications software, that it is set to use full-duplex, and that the baud rate is set to the appropriate setting (factory default is 19,200).

12 Using the serial interface, display the Main menu.

The Main menu looks like this.

```
Main Menu - Comm
-----
      .
      .
      .
[K] - Event log
[L] - System Functions Menu
[M] - Replay train
[N] - Security Menu
[X] - Exit
```

13 Select the **Auto-Calibration option** to calibrate the system's pyrometer interface circuitry.

The SmartScanNG² system will now calibrate itself. **Follow along on your computer screen until you see "Auto-Calibration Disengaged."** This message is an indication that the system is done with the calibration procedure. To abort the process, press **[Esc]** on your computer or remove the heat source from the wheel scanner.

Before the shutters are opened, if you get a signal level greater than 200 millivolts, it usually means that there is noise on the scanner inputs, which most times is caused by an electrical problem with the scanner. If you cannot isolate and fix the cause of this problem, call STC for help.

```
System Functions Menu
-----
[A] - Radio/Audio Menu
[B] - Start Manual Train
[C] - Auto-Calibration
[D] - Reboot System
[E] - Delete All Stored Train Data
[F] - Clear Event Log
[G] - Update Menu
[H] - Maintenance Menu
[I] - Resistor Baseline Data
[J] - Scanner Test
[K] - Calibrate Frauscher Transducers
[L] - Virtual Gate Test
[M] - AUX OUT Relay Menu
[X] - Exit
```

The handling of a scanner calibration request depends on the current battery voltage. Calibration requests are handled as follows:

- **Battery Okay:** Calibration proceeds normally.
- **Battery Low:** A message displays the current battery voltage and the Low Battery threshold, and a prompt asks the user whether to continue. If the user chooses to continue, the firmware records a "Scanner calibration requested during Low Battery (nn.nV) condition" Event Log entry where the current battery voltage appears in place of "nn.n." The following screenshot shows an example of the new displays.

```
System Functions Menu
-----
      .
      .
      .
[C] - Auto-Calibration
      .
      .
      .
[X] - Exit

Battery voltage (12.2V) is below the Low Battery threshold (12.6V).
Calibration is not advised. Continue with calibration? (y/n)
- or for 24V systems -
Battery voltage (19.3V) is below the Low Battery threshold (22.0V).
Calibration is not advised. Continue with calibration? (y/n)
```

Calibrating during a Low Battery condition will further drain battery power, shortening the time the detector remains operating. Additionally, the resistor baseline values used during the post-train resistor integrity test correspond to the battery voltage used during the acquisition of the baseline values. Gathering baseline values (which begins following calibration) during a Low Battery condition yields values that will not correspond to the values needed when the battery voltage returns to its normal operating level.

- **Battery Dead:** A message displays the current battery voltage and the Dead Battery threshold. The firmware now prohibits calibration during a Dead Battery condition. The following screenshot shows an example of the new displays.

```
Battery voltage (11.2V) is below the Dead Battery threshold (11.8V).
- or for 24V systems -
Battery voltage (16.8V) is below the Dead Battery threshold (18.0V).
!!! Calibration Prohibited !!!
```

The firmware will not open the scanner shutters once the battery voltage drops below the Dead Battery threshold. It does this to conserve battery power and keep the detector running for as long as possible. While running, the detector continues recording axles, scanning for auxiliary alarms, making voice announcements, and (if equipped) communicating with a central office.

Before the shutters are closed, if you don't get a calibrated temperature in the range 534°F to 546°F, it means that the scanner wasn't calibrated. If cleaning the optics doesn't solve your problem, replace the scanner cover-and-module assembly. If this doesn't solve your problem, call STC for help in fixing the problem.

- 14 When "Auto-Calibration Disengaged" is displayed on your computer, remove the calibrated heat source.
- 15 To return to the Main menu, type **X**.
- 16 To exit the serial interface and return the system to normal operation, type **X**.
- 17 Replace the black filter frame with the red one immediately following the successful completion of the auto-calibration function.

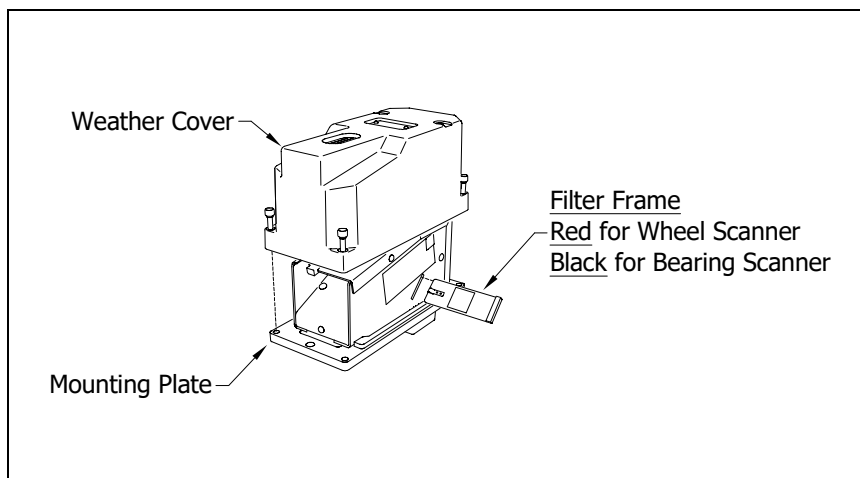

**** Before continuing, be sure that the red filter frame is securely in place and that the four socket-head-cap screws on the weather cover are completely tight. ****

- 18 Store the calibrated heat source and its power cord in the wayside enclosure.

NOTE:

Upon completion of autocalibration, the system acquires the scanner resistor temperature baseline values. The process begins with a 20-minute wait period in which the resistors are allowed to cool down. The system counts down during this period, sounding a tone each minute. After the 20-minute cool-down period, the system opens and closes the shutters for a period of 8 minutes.

Covering the apertures of all four scanners during the baseline acquisition routine should result in a more accurate baseline measurement because the reference for the scanner is stable when covered. See **Appendix J** for a detailed explanation and instructions.

F.3 Heat Source: Power Cable Warning

Warning - Caution

**PLEASE – ONLY USE THE POWER CORD
THAT WAS SHIPPED WITH THIS HEAT
SOURCE.**

USE OF THE OLD CORD WITH PINS IN THE
CONNECTOR WILL DAMAGE THIS HEAT SOURCE

The old-style power cord is a shock hazard because the connector is not “finger-safe.” As a result, the connectors on both the power cord and the heat source were changed.



Old-style plug with pins.

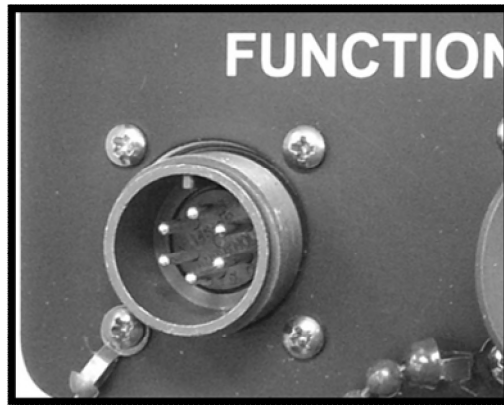

New heat source with pins.

If an old-style cable is forcibly connected to a new heat source, the reverse polarity of the mating connector pins will damage the heat source.

Appendix G

Lens Cleaning of Scanners

This appendix tells how to clean the optics in the scanners.

G.1 Type III Scanners

To clean the optics in the scanners:

- 1 Be sure that you have on hand a T-handle 1/4-inch hex-wrench.
- 2 Using the T-handle 1/4-inch hex-wrench, loosen the four socket-head-cap screws that attach the weather cover to the mounting plate.

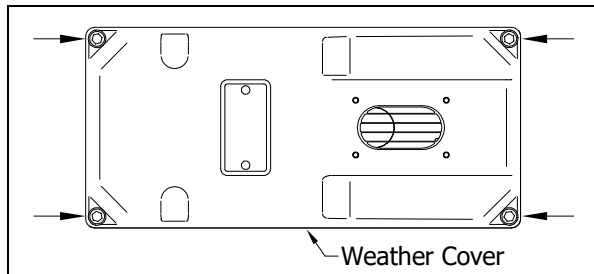

- 3 Remove the weather cover from its mounting plate.

Be careful not to damage the electrical connection for the cover heaters.

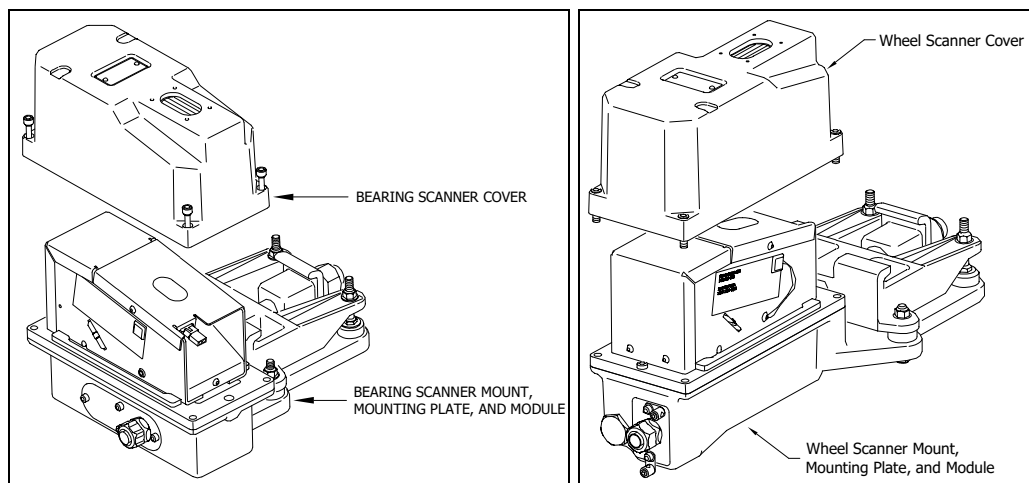

4 Disconnect the heater wiring plug.

On the side of the scanner module, you'll find a metal tab that protrudes about 1/4 inch outside the module.

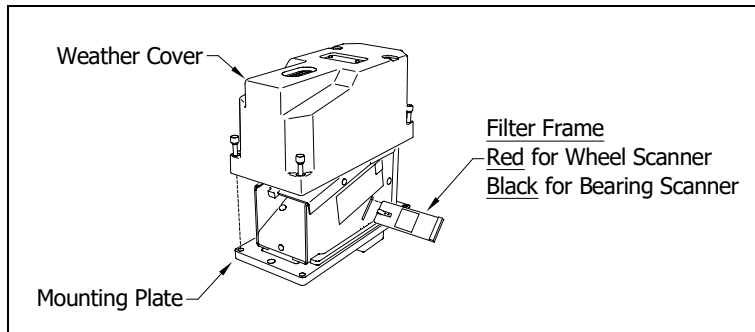

5 Grasp the tab and pull the filter frame out of the scanner module.

6 Using the brush supplied with the tool kit, lightly dust any excess material from the filter frame glass.

Be careful not to abrade or scratch the surface of the glass.

7 Apply a small amount of Vallen V8L cleaning solution (included in the tool kit) directly to the glass filter to loosen any remaining contamination.

8 Gently polish the reflective glass surface of the filter to remove any remaining contamination.

9 Open the shutter by stroking one of the gating transducers with a piece of ferrous metal.

10 If the lens surface appears to have any dust on it, insert the brush from the tool kit through the baffle plates until it contacts the lens surface and apply a twisting motion to dislodge any accumulated dust.

11 Remove the brush and visually inspect the lens for cleanliness.

12 Reinstall the filter frame assembly properly - (The reflective surface will be facing the viewport opening of the scanner). Reconnect the heater wiring plug.

13 Re-connect the scanner cover heater.

14 If this is a **bearing scanner**:

With the hole on top of the bearing scanner cover facing north or east, set the weather cover back onto its mounting plate. Using the T-handle 1/4-inch hex-wrench, uniformly tighten the four socket-head-cap screws.

15 If this is a **wheel scanner**:

With the hole on top of the wheel scanner cover facing the center of the track, set the weather cover back onto its mounting plate. Using the T-handle 1/4-inch hex-wrench, uniformly tighten the four socket-head-cap screws.

G.2 Type II Scanners

To clean the optics in the **Type II** scanners:

- 1 Be sure that you have on hand a T-handle 1/4-inch hex-wrench and a 9/64-inch Allen wrench.
- 2 Using the T-handle 1/4-inch hex-wrench, loosen the two socket-head-cap screws that attach the weather cover to the mount.

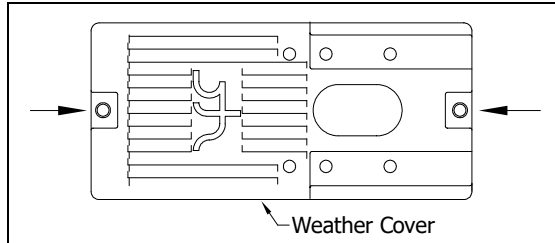

- 3 Separate the scanner cover-and-module assembly from its mount.

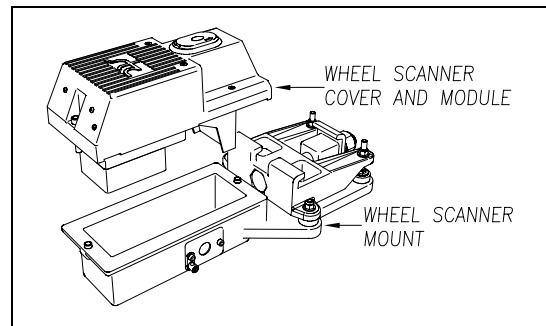
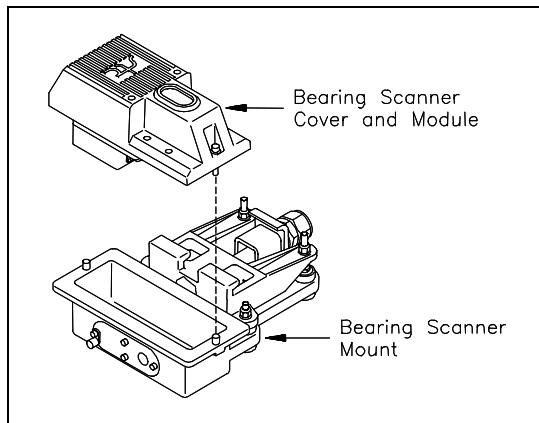

- 4 Disconnect the scanner cable connector from the scanner box connector.

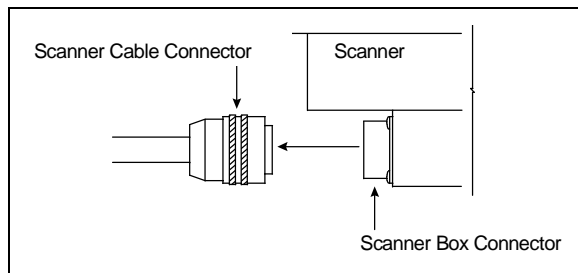

- 5 Turn the cover-and-module assembly upside down.
- 6 Using the 9/64-inch Allen wrench, remove the four socket-head-cap screws from the bottom panel.

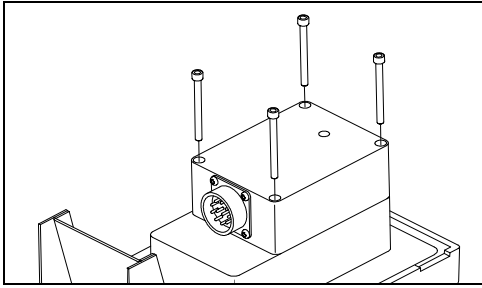

- 7 Store the socket-head-cap screws in a safe place until you replace it.
- 8 To expose the internal scanner module and lens assembly, separate the bottom panel of the scanner from the main body.

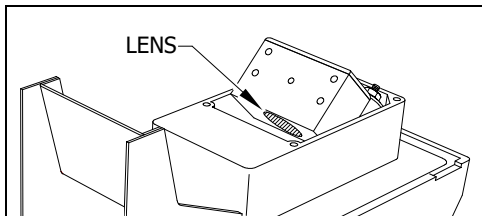

- 9 Using a soft, dry cloth, remove any accumulated dirt or grit.
Be careful not to abrade or scratch the surface of the lens.
- 10 Using a soft, clean cloth, apply a mild cleaning solution such as Vallen V8L or any similar solution that would typically be used for cleaning eyeglasses.
- 11 Gently wipe the entire surface of the lens surface.
- 12 To restore a uniform surface, gently polish the lens surface with a clean, dry cloth.
- 13 Reposition the bottom panel.
- 14 Replace the four socket-head-cap screws and tighten by hand.
- 15 Using the 9/64-inch Allen wrench, tighten the four socket-head-cap screws until they are completely tight.
Be sure that the screws are uniformly tightened.
- 16 Attach the scanner cable connector to the scanner box connector.
- 17 If this is a bearing scanner:
 - a With the hole on top of the bearing scanner cover facing north or east, set the cover-and-module assembly onto its mount.
 - b Using the T-handle 1/4-inch hex-wrench, uniformly tighten the two socket-head-cap screws.
- 18 If this is a wheel scanner:
 - a With the hole on top of the wheel scanner cover facing the center of the track, set the cover-and-module assembly onto its mount.
 - b Using the T-handle 1/4-inch hex-wrench, uniformly tighten the two socket-head-cap screws.

Appendix H

Predictive Gate Scanning

This appendix describes predictive gate scanning of bearings.

H.1 Overview

If a pyrometer is exposed to extreme infrared energy emission, the device itself can be driven into a saturated state. When this happens, it is blinded to subsequent changes in infrared energy emission. This blinded state can last up to 1-1/2 seconds.

Under certain circumstances, a pyrometer may be driven into saturation before the opening of the gate for a given axle. If the open-gate period was the only time during which pyrometer readings were sampled and processed, the system might miss an overheated bearing due to a device that was blinded before the opening of the gate. This can happen when a bearing is so overheated that it gives off infrared energy that can be seen by the pyrometer long before the bearing enters the pyrometer's field of view.

To compensate for this, the SmartScanNG² system includes special logic for processing heat seen by the pyrometers as they scan between the axle gates. The interval between axles has been divided into two parts.

The first part of this interval is the 12 inches (40.6 centimeters) that immediately precede the axle as it approaches the bearing scanners. This interval is treated as a "predictive gate" region in which the actual gate period (the time a bearing is physically in the pyrometer's field of view) is extended by 12 inches. The remainder of the "between gate" interval forms the second part. Heat values read during this second interval are ignored.

The figure below depicts the three distinct scanning intervals (the in-gate period plus the two between-gate intervals).

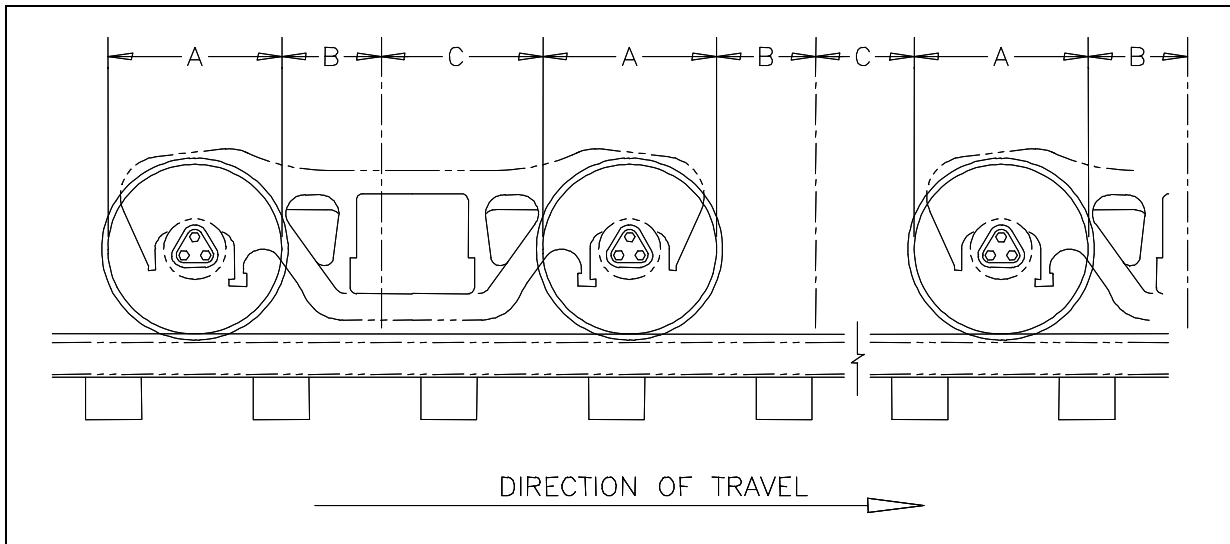

The table below defines the intervals.

Interval	Description
A	The normal bearing scanning interval of about 24 inches (61 centimeters), depending on the transducer spacing.
B	A distance of about 12 inches (40.6 centimeters) before a given wheel.
C	The distance between wheels that doesn't fall within interval-B.

H.2 Scanning Process

Interval-A is the normal bearing scanning interval. Interval-B is an extension of interval-A. The greatest value read in either of these two intervals is recorded as the temperature for the axle. This value is checked for alarm levels in the same manner that scanned bearing temperatures are normally handled.

For interval-A: Heat values read during interval-A are processed normally.

For interval-B: Heat values read during interval-B that do not meet or exceed the Absolute alarm threshold are ignored. Values that meet or exceed the Absolute alarm threshold are handled as follows:

If the interval-A heat value meets or exceeds the Absolute alarm threshold, it is processed normally, and the interval-B heat reading is ignored.

If the interval-A heat value does not meet or exceed the Absolute alarm threshold, but the interval-B heat value does, a Pyrometer Saturation alarm is flagged, and the interval-B heat value is stored and reported for the alarmed axle.

For interval-C: Heat values read during interval-C are ignored.

H.3 Reporting the Pyrometer Saturation Alarm

If a Pyrometer Saturation alarm is detected and assigned to an axle, a printed message will appear on Detail reports.

The figure below shows part of a Train Detail report with a Pyrometer Saturation alarm. The contents of your report will be different.

Southern Technologies Corporation										
Next Generation Detector System										
TRAIN DETAIL										
=====										
•										
•										
•										
Car	Axle	Rail		Wheel		ON	OFF	PW1	PW2	Alarms
		East	West	East	West					
1	1	58	30	98	102	35	0	16	17	
	2	58	30	98	102	35	82	13	13	
	3	219	30	98	102	35	85	13	13	East Rail Pyro Saturation Alarm
	4	58	30	98	102	35	839	13	13	
	5	58	30	98	102	35	85	13	13	
	6	58	30	98	102	35	85	13	13	
2	7	58	30	98	102	35	238	13	13	
	8	58	30	98	102	34	85	13	13	
•										
•										
•										

Appendix I

2500-402 Spacer Kit Installation

The 2500-402 Spacer Kit provides the hardware necessary to lower the Type III Hot Wheel Scanner assembly by either 1/2" or 1" for those applications that require additional rail clearance.

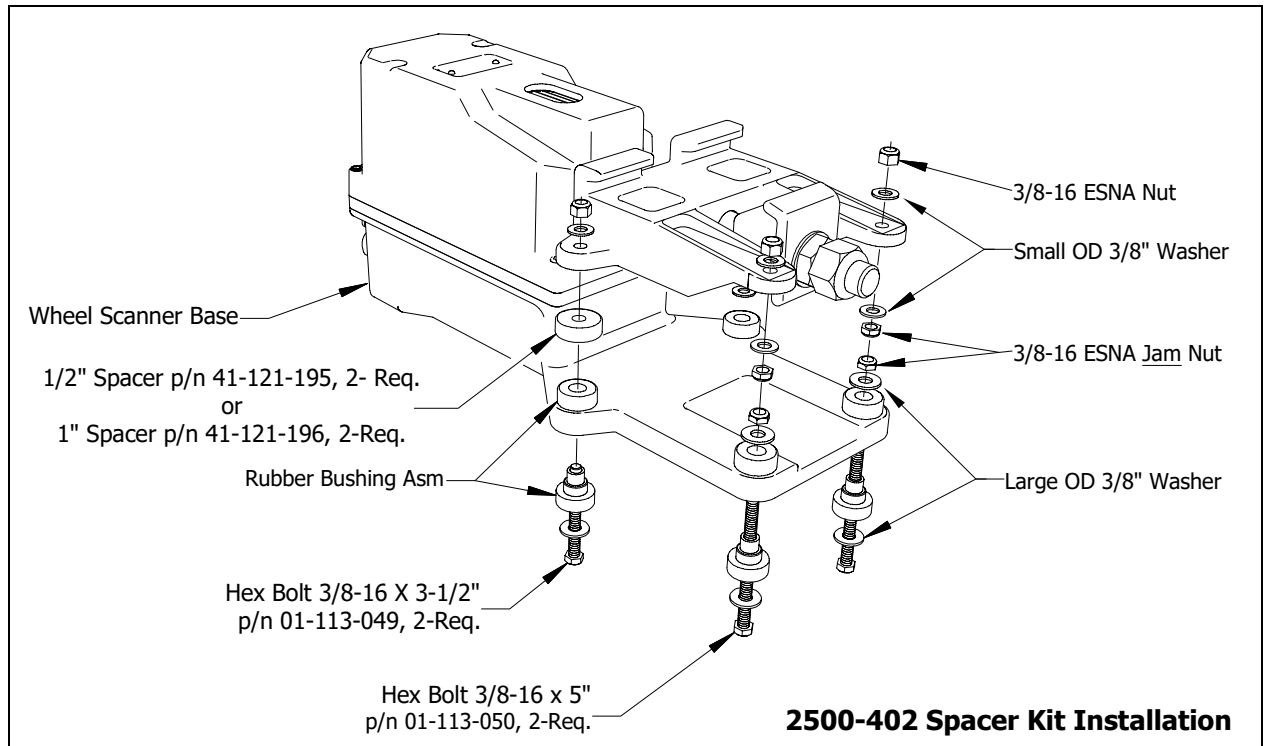
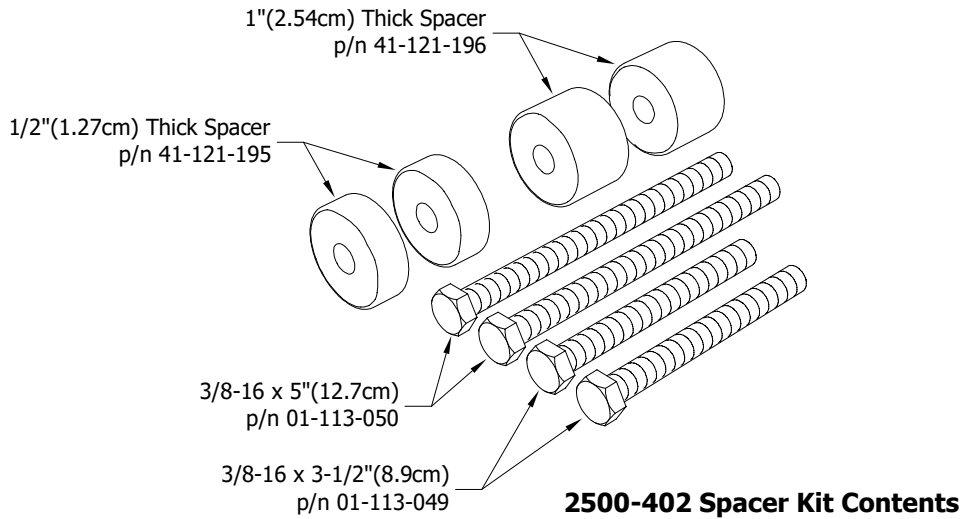

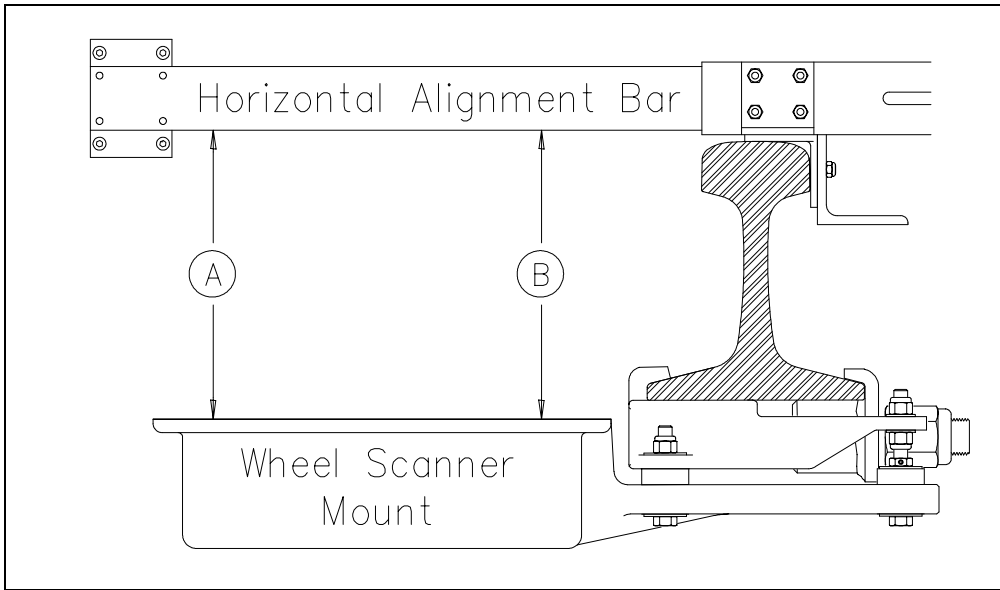

Wheel Scanner Alignment:

Place the Alignment Fixture on the rails so that the adjustable gauge slide is over both wheel scanners. Extend the horizontal alignment bar of the fixture as far as it will go. At both ends of the scanner mount, measure from the bottom of the extended bar to the top surface of the mount.

When both measurements are the same, alignment is correct. That is, as shown above when distance **A** is equal to distance **B**, alignment is correct.

NOTE: Alignment is the same regardless of spacers.

Appendix J

Scanner Resistor Baseline Acquisition

Upon completion of autocalibration, the system will acquire the scanner resistor temperature baseline values. The process begins with a 20-minute wait period in which the resistors are allowed to cool down. The system counts down during this period, sounding a tone each minute. After the 20-minute cooldown period, the system opens and closes the shutters for a period of 8 minutes.

NOTE: For wheel scanners, it is imperative that the red filter frame is replaced immediately after autocalibration has disengaged and before resistor baseline acquisition begins.

The reason for establishing the baseline tables at the end of the Auto-Cal cycle is the assumption that the system is then at its peak operating efficiency. The system is freshly calibrated, and the lenses are clean. With the baselines established, the system can then recognize and compensate for slight degradations of the lens caused by moisture or dirt accumulation on the lens surface.

J.1 Bungalow Speaker Announcements

During the resistor-cooling period, the system voices the following announcements through the speaker (not broadcast over the radio):

- A beep sounds once per minute until two minutes before the resistor test.
- At two minutes until the test, "Scanner resistor test beginning in 2 minutes" is voiced.
- At one minute until the test, "Scanner resistor test beginning in 1 minute" is voiced.

After the resistor cooling period:

- As the test begins, "Testing" is voiced. During this time, the word PENDING appears in the status column of the Resistor Baseline Data report. To view this report, select the **Resistor Baseline Data** option from the System Functions Menu.
- If the test was successful, "System working" is voiced. The word VALID appears in the status column of the Resistor Baseline Data report, signifying that the baseline test applies to each passing train.
- If the test wasn't successful, "Scanner resistor test beginning in two-zero minutes" is voiced, meaning that the system will try once more after 20 minutes to acquire an accurate resistor heat profile. During this time, the word PENDING appears in the status column of the Resistor Baseline Data report. If the test fails a second time, the word INVALID appears in the same column. The system applies the interim integrity test to each passing train while either PENDING or INVALID appears.

Resistor Data																			

VOLTS	AMB	DATE	TIME	STATUS	30	40	50	60	70	80	90	100	110	120	130	Offset			
	140	160	180	200	220	240	260	280	300	320	340	360	380	400	420	440	460	480	

-																			
Rail 1 (Type III)																			
24.5	36	12/13/22	14:56	VALID	208	238	262	277	282	282	282	282	282	282	282	282	282	282	18
					282	282	282	282	282	282	282	282	282	282	282	282	282	282	
Rail 2 (Type III)																			
24.5	36	12/13/22	14:56	VALID	200	233	262	277	281	281	281	281	281	281	281	281	281	281	19
					281	281	281	281	281	281	281	281	281	281	281	281	281	281	
Wheel 1 (Type III)																			
24.5	36	12/13/22	14:56	VALID	220	242	270	277	276	286	293	296	305	309	306				20
					315	320	326	329	338	340	340	343	348	300	300	300	300	300	
Wheel 2 (Type III)																			
24.5	36	12/13/22	14:56	VALID	200	231	267	281	288	292	306	308	326	326	328				24
					330	336	342	354	354	361	365	368	366	300	300	300	300	300	

J.2 Processing Resistor Baseline Results

Here are the two rules the system uses:

- If any of the samples in the baseline table are less than or equal to 40°F, we consider the baseline to be invalid.
- The next sequential sample has to increase or be no more than 6°F cooler than the last sample. For example, if a temperature sample is 100°F, the next sample must be 94°F or greater.

If the system gets an invalid baseline or gets interrupted, it will automatically try a second time. The 300° F temperatures that occasionally show up in the baselines are more a reflection of the duty cycle controller for the shutter resistor. Some controllers cause the shutter resistors to heat up more quickly and overshoot the desired set point, whereas a controller operating at its optimum efficiency will ramp up to a value slightly below 300° F. Temperatures above 300° F do not result in an invalid baseline.

Look at the Resistor Data section of the System Status Report. INVALID indicates that the system has tried twice and could not acquire valid resistor data. If any of the baseline results for a scanner show INVALID, the only way to capture a new baseline is to run the Auto Cal process again. If the word PENDING appears in the status column, the system is waiting for the resistors to cool before acquiring resistor data or for the battery to charge to 13 volts (12V system) or 26 volts (24V system). INVALID indicates that the system has tried twice and could not acquire valid resistor data. In either case, the system will apply the interim integrity test to passing trains, which doesn't require resistor baseline data.

Examples: Resistor Baseline Results

Resistor Data																	
VOLTS	AMB	DATE	TIME	STATUS	30	40	50	60	70	80	90	100	110	120	130		
140	160	180	200	220	240	260	280	300	320	340	360	380	400	420	440	460	480
RAIL 1																	
15.3	-008	01/11/12	12:53	INVALID	300	300	300	300	300	300	300	300	300	300	300	300	300
RAIL 2																	
15.3	-008	01/11/12	12:53	INVALID	300	300	300	300	300	300	300	300	300	300	300	300	300
WHEEL 1																	
15.3	-009	01/11/12	12:26	VALID	155	152	155	152	150	150	149	149	148	147	147	148	149
WHEEL 2																	
15.3	-009	01/11/12	12:26	VALID	160	156	157	162	157	157	155	155	156	155	156	155	156

Resistor Data																	
VOLTS	AMB	DATE	TIME	STATUS	30	40	50	60	70	80	90	100	110	120	130		
140	160	180	200	220	240	260	280	300	320	340	360	380	400	420	440	460	480
RAIL 1																	
13.4	057	09/30/11	11:59	INVALID	285	285	289	294	289	288	289	288	287	287	288	287	289
RAIL 2																	
13.4	055	09/30/11	10:50	VALID	272	271	274	280	277	275	270	264	262	264	271	277	278
WHEEL 1																	
13.4	055	09/30/11	10:50	VALID	145	148	154	155	156	157	156	156	157	160	158	160	160
WHEEL 2																	
13.4	055	09/30/11	10:50	VALID	128	132	137	137	138	137	141	138	138	141	140	141	142

Resistor Data																	
VOLTS	AMB	DATE	TIME	STATUS	30	40	50	60	70	80	90	100	110	120	130		
140	160	180	200	220	240	260	280	300	320	340	360	380	400	420	440	460	480
RAIL 1																	
13.5	061	05/25/11	15:25	VALID	242	251	258	263	264	265	267	268	268	270	271	272	275
RAIL 2																	
13.5	061	05/25/11	15:25	VALID	262	268	274	282	282	282	282	283	284	285	285	288	289
WHEEL 1																	
13.7	063	06/27/11	14:09	INVALID	112	116	117	117	116	116	114	114	112	112	111	110	112
WHEEL 2																	
13.7	063	06/27/11	14:09	INVALID	135	2	2	2	2	2	2	148	2	2	2	2	2

Appendix K Communications Ports

NOTE: The factory default setting for serial ports COM1-COM5 is 19,200 baud. The default setting for the RS485 port is 9,600 baud. COM-6 default is 57,600 baud.

COM1 – To use the serial interface, connect a local computer (DTE) using a null-modem cable and set the communications software to use full-duplex.
This is the standard local access port.

COM2, COM4, & RS485 - Currently unused.

COM3 – Used to communicate with the Velocity Modem board's instruction set and database. COM3 is connected to Port 2 on the Velocity Modem board.

COM5 – At systems with AEI, attach a null-modem cable from the AEI (DTE) Interface Module to COM5 (DTE) of the Controller module.

COM6 – Used to load a software update package onto the NG².

ETHERNET – To establish an Ethernet connection, you need a network interface card (NIC) in your computer and a Category 5 (CAT5) 8-wire network cable for basic 10/100 functionality.

DCE (Data Circuit-Terminating Equipment) Modem				Connecting Cable	DTE (Data Terminal Equipment) Computer			Connecting Cable	DTE (Data Terminal Equipment) Computer		
Pins on the Modem		Name and Abbreviation		Inside the Straight-Through Connecting Cable	Abbr.	Pins on the Computer		*Inside the Null-Modem Connecting Cable	Abbr	Pins on the Computer	
Female DB25	DB9					Male DB25	DB9			Male DB25	DB9
1	-	Frame Ground (Chassis)	FG	————	FG	1	-	————	FG	1	-
2	3	Transmitted Data (TD)	TxD	←————	TxD	2	3	↔	TxD	2	3
3	2	Received Data (RD)	RxD	————→	RxD	3	2	↔	RxD	3	2
4	7	Request to Send	RTS	←————	RTS	4	7	↔	RTS	4	7
5	8	Clear to Send	CTS	————→	CTS	5	8	↔	CTS	5	8
6	6	Data Set Ready	DSR	————→	DSR	6	6	↔	DSR	6	6
7	5	Signal Ground	SG	————	SG	7	5		SG	7	5
8	1	Data Carrier Detect	DCD or CD	————→	DCD or CD	8	1		DCD or CD	8	1
20	4	Data Terminal Ready	DTR	←————	DTR	20	4		DTR	20	4
22	9	Ring Indicator	RI	————	RI	22	9	————	RI	22	9

Appendix L

Scanner Base Drain Hole

For scanners manufactured prior to 2013:

Where required due to water accumulation, a 0.25" drain hole can be drilled in the bottom of the scanner base.

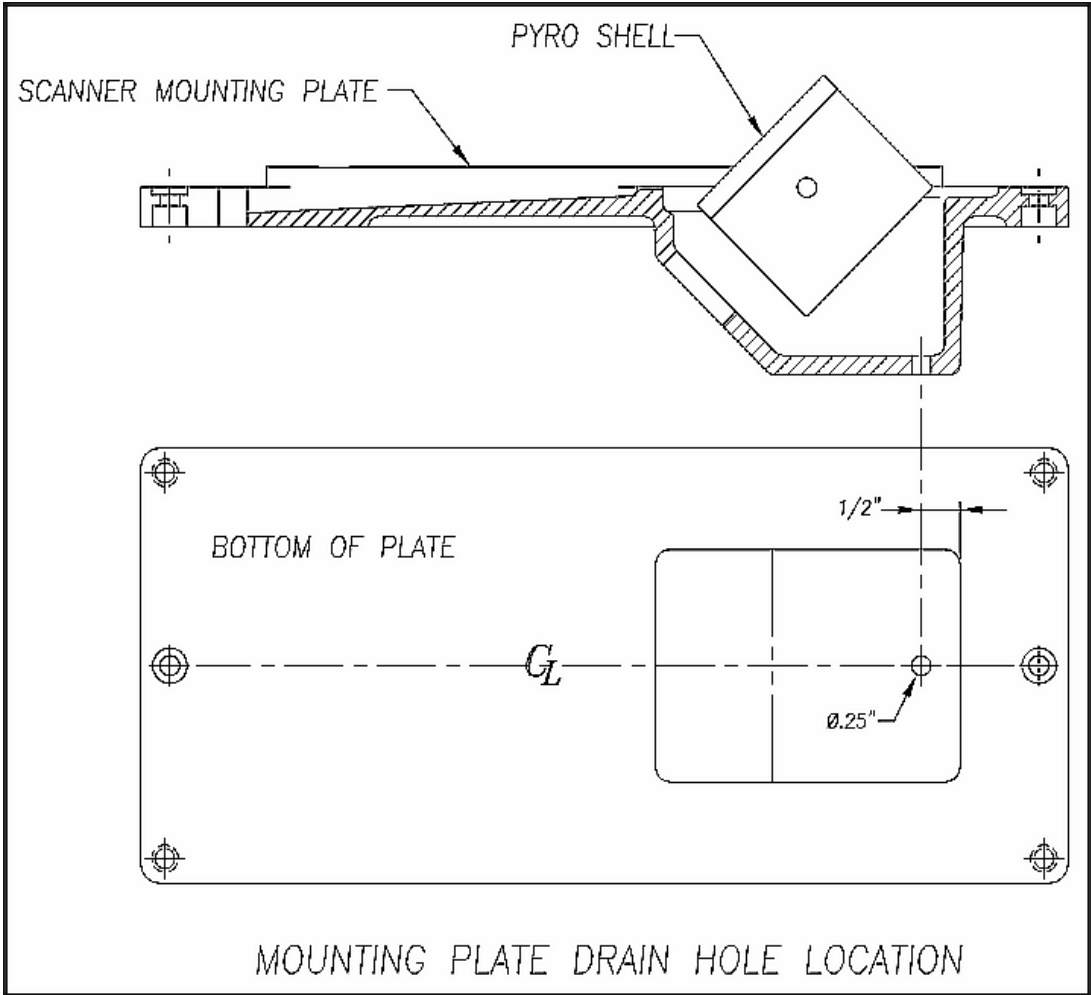

Appendix M

Calibration of the PD8-Plus Presence Detector

1. Obtain track & time authority.
2. From the center of the gating transducers, measure the distance you want the track circuit to pick up the presence of a train.
3. The recommended distance is at least 50' (15.24 m) and no more than 150' (45.7 m).
4. At the point just measured, place a 0.06Ω shunt across both rails. The track must be shunted before the calibration switch is pressed.
5. Press and HOLD the Calibration Switch until the relay drive LED starts blinking. Release the switch, and the LED will stop blinking. The ZEPIC III will automatically begin the calibration process. NOTE: The track shunt MUST remain in place during the calibration process.

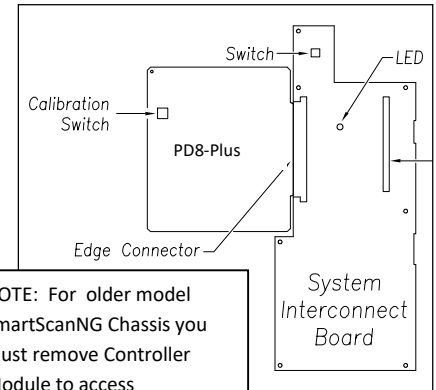

NOTE: the relay drive LED is the same as the SOTC LED visible on the lower right side of the NG² Chassis cover

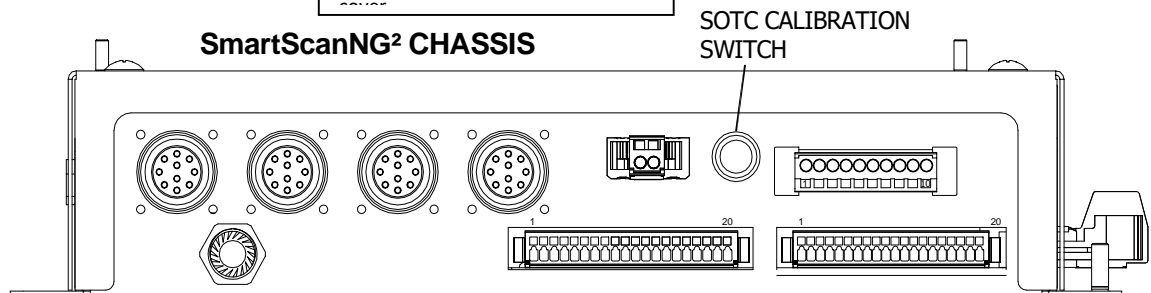

6. The relay drive will pick up (LED on) when the unit has successfully calibrated. This process can take up to 45 seconds to complete.

Verification

1. After calibration, lift the shunt, and the relay drive should drop (LED off). Replace the shunt, and the relay drive will pick up (LED on).
2. Move the shunt approximately 10' farther out from the calibration point. The relay drive should not pick up (LED stays off). If this test fails, perform Short Track Calibration (detailed below).
3. The PD8-Plus is now operating properly and will activate at an equal distance on either side of the track feed point.

4. After trackside calibration procedures have been successfully completed, place a temporary shunt across the track wires inside the bungalow and verify that the signal system goes to stop. Once verified, remove the temporary shunt.

IMPORTANT: To ensure an accurate activation point, always place the shunt BEFORE pressing the Calibration Switch.

If the PD8-Plus cannot achieve calibration, it will blink the relay drive LED three (3) times in rapid succession, indicating a calibration error. The unit will continuously repeat the calibration procedure (there is no need to press the Calibration Switch), allowing you to troubleshoot the track circuit, wiring, and battery. Once the issue has been corrected, repeat the calibration procedure.

Both the ZEPIC III and Zepic PD8-Plus have a two-wire track circuit and will activate an equal distance on both sides of the track feed point.

PD8-Plus Short-Track Circuit Calibration

1. The system may fail the 10 ft calibration verification step noted above if the installation is using 26KHz and the desired CAL point is ~30ft from the feed points (Short track circuit), and the bungalow is near the track (short track wires).
2. If this is the case, reconfigure the PD8-Plus to a lower frequency that is compatible with other equipment that may be on the track. In general, changing from 26KHz to 20KHz or 17.5KHz should solve the short-track circuit calibration issue.
3. Once the module has been reconfigured for the new operating frequency, repeat the normal calibration procedure detailed above.

PD8-Plus Troubleshooting and Application Notes

1. If the unit will not calibrate, watch the relay drive LED for approx 45 seconds. If it blinks, this means the PD8-Plus has turned its receiver gain to the maximum setting and cannot see the track shunt. Look for open circuits between the PD8-Plus and the shunt on the track. I.e., track wires, bond wires, etc.
2. The PD8-Plus will look equally in both directions. If one side of the circuit has insulated joints, the PD8-Plus will operate. However, the activation distance will not be the same. In general, track circuit equipment cannot see past insulated joints.
3. Audio overlay systems like the PD8-Plus will not work with wideband shunts in their track circuit range.
4. If the relay drive is stuck ON, look for short circuits between the PD8-Plus and the desired pick point.
5. The greater the distance between the PD8-Plus and track connections, the greater the effects ballast will have on the PD8-Plus performance.
6. Presence output is a dry contact configuration Form –C dry contact, 225mA max current. (N.O. contact with no train presence)
7. In good track ballast conditions, a PD8-Plus circuit can travel up to 500 ft in each direction. Rotating operating frequencies to avoid interference with other equipment is recommended.
8. The higher the operating frequency, the shorter the track circuit.

Appendix N

Track Circuit Frequency Configuration

The Zepic PD8-Plus module is capable of outputting the following track drive frequencies: 8.2K, 10K, 11.5K, 13.2K, 15K, 17.5K, 20K, 26KHz. These track frequencies can be configured in the field without the need of specialized tools. The figure below details the switch and TAP setting required to configure the unit for each frequency.

Note: Perform the calibration procedure after changing the track frequency.

Frequency Selection

S3-1, S2-1, TAP1=8.2KHz	S3-5, S2-5, TAP5 =15KHz
S3-2, S2-2, TAP2=10KHz	S3-6, S2-6, TAP6 =17.5KHz
S3-3, S2-3, TAP3=11.5KHz	S3-7, S2-7, TAP7 =20KHz
S3-4, S2-4, TAP4=13.2KHz	S3-8, S2-8, TAP8 =26KHz

Always use the same switch # and TAP #, do NOT mix.

S3

All OFF except desired Frequency
One and only one on at a time.

S2

All ON except desired Frequency
One and only one off at a time

To select a TAP, unscrew the hex stand-off and move to the desired TAP. Use 1/4 turn, do NOT over tighten.

Example:

PD8-Plus Configured for 26 KHz

TAP 1-8

Stand-Off on TAP8
(1/4 turn to tighten)

Switch 3 Switch 2

All Switches of S3
OFF except SW3-8

SW3-8 ON

All Switches of S2
ON except SW2-8

SW2-8 ON

NOTE: Older model track circuit boards have a fixed drive frequency and are not configurable.

Appendix O

AAR Radio Frequencies

Listed by AAR Channel Numbers

AAR Channel	Frequency MHz
(1)	159.910?
2	159.930
3	160.025
4	160.085
5	160.115
6	160.170
7	160.215
8	160.230
9	160.245
10	160.260
11	160.275
12	160.290
13	160.305
14	160.320
15	160.335
16	160.350
17	160.365
18	160.380
19	160.395
20	160.410
21	160.425
22	160.440
23	160.455
24	160.470
25	160.485

AAR Channel	Frequency MHz
26	160.500
27	160.515
28	160.530
29	160.545
30	160.560
31	160.575
32	160.590
33	160.605
34	160.620
35	160.635
36	160.650
37	160.665
38	160.680
39	160.695
40	160.710
41	160.725
42	160.740
43	160.755
44	160.770
45	160.785
46	160.800
47	160.815
48	160.830
49	160.845
50	160.860

(continued on next page)

(AAR Radio Frequencies continued)

AAR Channel	Frequency MHz
51	160.875
52	160.890
53	160.905
54	160.920
55	160.935
56	160.950
57	160.965
58	160.980
59	160.995
60	161.010
61	161.025
62	161.040
63	161.055
64	161.070
65	161.085
66	161.100
67	161.115
68	161.130
69	161.145
70	161.160
71	161.175
72	161.190
73	161.205
74	161.220
75	161.235

AAR Channel	Frequency MHz
76	161.250
77	161.265
78	161.280
79	161.295
80	161.310
81	161.325
82	161.340
83	161.355
84	161.370
85	161.385
86	161.400
87	161.415
88	161.430
89	161.445
90	161.460
91	161.475
92	161.490
93	161.505
94	161.520
95	161.535
96	161.550
97	161.565
(98)	161.580?
(99)	161.595?
(100)	161.610?

†Frequency data retrieved from: http://kohlin.com/freq/AAR_freqs.htm (last updated June 2000)

Index

This section lists the page numbers for keywords and phrases used in this guide.

1

19,200 baud · 271
1KHz test tone · 87

A

Absolute option · 140, 147, 153
advance transducers · 211, 221
AEI Diagnostic Detail report · 111, 137, 170, 173, 174
AEI option · 65, 141, 143, 144, 155, 156, 159, 170
AEI Reader Parameters · 69, 71
AEI tags · 141, 148
alarm
 Absolute · 17, 42, 262
 AC Power Is Off · 211
 Carside Slope · 17, 51, 52, 53, 140, 143, 144, 148, 153, 155, 156, 159, 180, 220
 Cold Rail · 43, 44, 140, 147, 153, 212, 219, 222
 Cold Resistor · 147, 212, 213, 216, 222
 Cold Wheel Scanner Resistor · 213, 217
 Dead Battery · 181, 215, 219
 Dead Resistor · 219
 Differential · 17, 42
 Dragging Equipment · 21, 49, 50
 Efficiency Test Panel in Use alarm · 214
 Equal Heats Test Failed · 214, 220
 Exception · 65, 148, 149, 152, 154
 Exception Alarm · 182, 189, 190
 High-Load · 21, 22, 50
 High-Load alarm · 189
 Highrange Transducer Miscounts · 214, 215, 219, 220
 Hot Wheel · 21, 43, 50, 51, 143, 147, 155, 184, 188
 Hotbox · 147
 Hotbox alarm · 180, 184, 185, 188
 Integrity Failure · 214, 222
 Low Battery · 215, 219
 Max Equal Heat Test Failures Exceeded · 214, 220
 Midrange Transducer Miscounts · 215, 220
 No Approach Track · 196, 211
 Pyrometer Noise Filtered Rail · 215
 Pyrometer Noise Filtered Wheel · 216
 Pyrometer Saturation · 17, 262, 263
 Rail Resistor Test Overridden · 213, 216
 Reverse Direction Detected · 216
 Short Train · 217
 Stuck Dragger During Train Passage · 221
 Stuck Dragger Pretrain · 221
 Stuck High Load Detector Pretrain · 22, 221
 Stuck Wide Load Detector Pretrain · 22, 221
 Successive Cold Rails Exceeded · 43, 212, 222

Successive Cold Resistors Exceeded · 43, 213, 222
Successive Cold Wheel Resistors Exceeded · 213, 217
Test Train · 217
Train Present on Restart · 222
Very Slow Train · 199, 214, 215, 220
Wheel Resistor Test Overridden · 217
Wide-Load · 22, 49, 50
alarm Limits submenu · 178, 214, 220
Alarm Settings menu · 21, 39, 41, 42, 43, 44, 140, 147, 148, 153, 164
alignment · 191, 192
ambient temperature · 19, 21, 42, 43, 44, 55, 63, 64, 104, 141, 146, 163, 172
ancillary messages · 63, 181, 182, 183, 184, 189, 190
Announce Axles option · 63
Announce Car Identification option · 65
Announce Customer Name option · 65
Announce Left-Right Alarm Reference option · 65
Announce Power Off option · 64
Announce Slow Train option · 14, 64
Announce Speed option · 63
Announce Temperature option · 64
Announce Train Length option · 64
announcements · 79, 178, 179, 180, 184, 186, 187, 189, 190
antenna · 148
arrival message · 178
attenuation plug · 223
autocalibration · 26, 92, 104, 204, 233, 235, 238, 241, 243, 245, 247, 250, 253, 255
auxiliary alarm · 187
Auxiliary alarms · 21
Axle Alarm Summary · 148
axle count · 63, 181, 199, 200, 202
axle number · 149
Axle Scanning · 16

B

ballast · 192
baseline resistor integrity · 103, 147
battery charger · 193, 194, 195, 208
battery temperature probe · 193
baud rate · 32, 234, 240, 246, 252
bearing scanners · 7, 13, 17, 18, 21, 141, 146, 149, 199, 223, 227, 261

C

calibrated heat source · 26, 233, 234, 238, 239, 240, 243, 245, 246, 250, 251, 252, 255
Clear Event Log option · 96
clearance mode · 54
clearance type · 53
Cold Trains · 214
COM1 · 32, 75, 137, 234, 240, 246, 252, 271
COM3 · 31
COM5 · 271
correction factor · 19, 147, 213

D

Date and Time · 36

default setup parameters · 72, 74
Delete All Stored Train Data option · 96
directory · 154
Display Panel · 23
double-track site · 183
Dragger option · 21, 49
Dragging Equipment Detector · 180, 186, 187
DTMF · 67

E

Efficiency Test panel · 30, 214
Equipment Settings menu · 21, 22, 43, 48, 49, 50, 51, 52, 53, 54, 55, 57, 58, 59, 60, 62, 65, 141, 143, 144, 148, 149, 164
Equipment submenu · 55, 56
error message · 56, 67
Event Log · 96, 97, 111, 132, 137, 175, 176
Exception Detail report · 137, 150, 151, 152, 155, 156, 158, 159, 160
Exception Summary report · 137, 152, 154, 155
Exceptions directory · 96, 152

F

float voltage · 194, 195, 208
fuse block · 193, 194

G

Gate Distance option · 49, 57
gating transducers · 13, 14, 15, 16, 17, 19, 20, 57, 149, 173, 196, 199, 200, 206, 207, 214, 215, 216, 219, 220

H

heaters · 13, 55, 56, 257
Holdoff · 177
Holdoff timer · 177

I

Integrity Failure · 182, 183, 184, 185, 190, 214, 215, 220, 222

K

Keypad · 24

L

Lens Cleaning · 257

M

Main menu · 234, 238, 241, 243, 246, 250, 253, 255
Maintenance email list · 101
Messages menu · 177
Messages submenu · 181, 182, 188, 190
milepost · 183, 188
milepost/kilometer post · 38
modem · 234, 240, 246, 252
mounting plate · 227, 228, 229, 230, 231, 239, 252, 257, 258
MPRR · 69

N

Network Menu · 26
Network Settings · 76
no-defects message · 182

O

OLED · 24
optics · 238, 243, 250, 255, 257, 259

P

Post-Train Messages · 180
presence detector · 275
Processor board · 23
PTT · 26
pyrometer · 26, 233, 235, 241, 245, 247, 253

R

Radio Inhibit · 86
Radio Menu · 27
Radio Test · 25, 84
rebroadcast · 181, 189, 190
Remote System Reset · 95
Replay train · 109
reports
 Abbreviated Exception Detail · 150, 159
 AEI Diagnostic Detail · 170
 Exception Detail · 155, 183
 Exception Summary · 152
 System Status · 161
 Train Detail · 143
 Train Summary · 139

S

scanner cable · 259, 260
scanner cover · 227, 228, 230, 231, 238, 243, 250, 255, 258, 259, 260
scheduled maintenance · 191

Security Menu · 109
serial interface · 234, 238, 241, 243, 246, 250, 253, 255
Setup menu · 34
shutters · 212, 237, 238, 241, 243, 249, 250, 253, 255
single-track site · 180, 182, 184, 185, 186, 187, 188, 189
snow cycle · 56
Start Manual Train · 91
System Functions menu · 25, 84
system health menu · 25
System Status report · 161
system warning · 24

T

Talker Mode · 79, 190
TO1 · 214, 215, 216, 219, 220
TO2 · 214, 215, 216, 219, 220
track circuit · 211, 221
Track Designation · 80
Track Direction · 79
train alarm · 214
Train Detail report · 143
train speed · 181
Train Summary report · 139
tripwire · 188, 189
Type II · 259, 260

U

Update Menu · 97

V

View maintenance statistics · 99
Vocabulary Test · 85
Volume Menu · 27

W

wayside enclosure · 238, 243, 250, 255
Web security settings · 89, 103, 104
web user interface · 111
wheel scanners · 227

Z

Zepic III · 275